

AIR TO WATER HEAT PUMP

HEATING AND COOLING

MONOBLOC TYPE

DC INVERTER

Refrigerant
R290

INSTALLATION AND INSTRUCTION MANUAL GB

KEEP THIS MANUAL FOR FUTURE REFERENCE

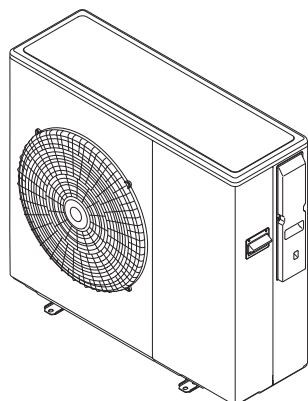

AEYC-0449ZU-CH1

AEYC-0649ZU-CH

AEYC-0649ZU-CH1

AEYC-0849ZU-CH

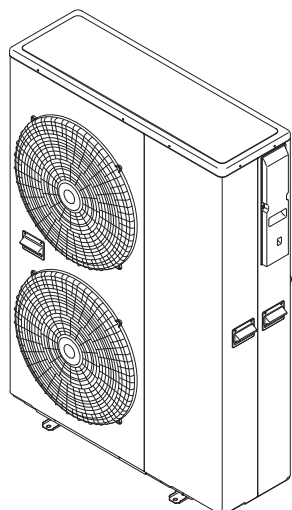

AEYC-1049ZU-CH1

AEYC-1249ZU-CH

MADE IN JAPAN

1. Responsibility and recommendations	3		
2. Specifications.....	11		
3. Installation	13		
3.1 Notice for safety installation			
3.2 Positioning and securing			
3.3 Main components			
3.4 Pressures and quantity available at heat pump outlet			
3.5 Water circuit connection			
3.6 Electrical connections			
3.7 Remote controller			
4. Remote controller.....	31		
4.1 Buttons			
4.2 Display panel			
5. Operation and functions			
of the Remote controller.....	33		
5.1 System ON/OFF			
5.2 Setting the day and time			
5.3 Selecting the operating mode			
5.4 Domestic Hot Water production			
5.5 Setting the time bands for Heating/Cooling			
5.6 Setting the time bands for DHW, Low tariff and Night mode			
5.7 Procedure for accessing the Parameter setting menu			
6. Electrical connections	54		
6.1 PCB(Terminal)			
6.2 PCB(Terminal) Input/Output			
6.3 Parameters Input/Output			
7. Unit Management.....	58		
7.1 Operating modes			
7.1.1 Select mode from user interface			
7.1.2 Select mode by remote contact			
7.2 Water temperature set point			
7.2.1 Fixed set point			
7.2.2 Climatic curve			
7.2.2.1 Heating Climatic curves			
7.2.2.2 Cooling Climatic curves			
7.2.3 Additional Outdoor air temperature probe for Climatic curves			
7.2.4 Buffer tank temperature probe			
7.2.5 HP unit control			
7.2.5.1 HP unit controlled based on Outgoing water temperature			
7.2.5.2 HP unit controlled based on Outgoing water temperature and Room air temperature			
7.2.5.3 HP unit controlled based on Buffer tank temperature			
7.2.5.4 HP unit controlled based on Buffer tank temperature and Room air temperature			
7.2.5.5 HP unit controlled based on DHW tank temperature			
7.3 Water pump management			
7.3.1 Main water pump			
7.3.1.1 Continuous operation "Always ON"			
7.3.1.2 Sniffing operation "Sniffing cycle"			
7.3.1.3 Unlock pump function			
7.3.1.4 Pump output adjustment function			
7.4 Frost protection			
7.4.1 Frost protection based on Room air temperature			
7.4.2 Frost protection based on Outdoor air temperature			
7.4.3 Frost protection based on Outgoing water temperature			
7.4.4 DHW tank frost protection			
7.4.5 Secondary system circuit frost protection			
7.5 Input/Output contact			
7.5.1 Heating/Cooling mode remote contact			
7.5.2 ON/OFF DHW production remote contact			
7.5.3 ON/OFF remote contact			
7.5.4 EHS Alarm			
7.5.5 Flow switch			
7.5.6 Dual set point control			
7.5.7 Additional water pump			
7.5.7.1 Additional water pump1			
7.5.7.2 Additional water pump2			
7.5.8 Heating/Cooling mode output			
7.5.9 Configurable contact (Alarm)			
7.5.9.1 Alarm			
7.5.9.2 Ambient temperature reached			
7.5.10 Night mode			
7.5.11 Low tariff			
7.5.12 Dehumidifier management			
7.5.13 Space Heating management			
8. Domestic Hot Water Production.....	104		
8.1 DHW 3way valve management			
8.1.1 Max time for DHW request			
8.1.2 DHW 3way valve change over time			
8.2 DHW production mode			
8.2.1 Heat pump only			
8.2.2 DHW Electric heater only			
8.2.3 Heat pump + DHW heater			
8.2.4 Legionella prevention function			
8.3 Backup heater			
8.3.1 Backup heater in Replacement mode			
8.3.2 Backup heater in Supplementary mode			
8.3.3 Freeze protection function			
8.4 EHS (External heat source)			
8.4.1 EHS in Replacement mode			
8.4.2 EHS in Supplementary mode			
9. Parameter List	131		
9.1 Access limitation			
9.2 Parameter table			
10. Installation check and Test operation.....	145		
10.1 Installation check			
10.2 Test operation			
11. Service and Maintenance	147		
11.1 Error code display			
11.2 Error history display			
11.3 Method of reset error code display			
11.4 List of Error codes			
11.5 Check and troubleshooting			
11.6 Monitor display function			
11.7 Maintenance			

1. Responsibility and recommendations

General Information

- Carefully read this manual and keep it for future reference.
- Carefully evaluate the potential risks before carrying out any repair or maintenance, and take the necessary precautions to guarantee personal safety.
- Do not attempt to repair, move or re-install the unit without the help of a qualified technician.

Responsibility

The manufacturer declines every responsibility and declares the warranty on the unit void in the event of damages caused by:

- Incorrect installation, including noncompliance with the instructions contained in the relative manuals.
- Modifications or errors in the electric or cooling or hydraulic connections.
- Unauthorised coupling of other units, including units from other manufacturers.
- Use of the unit in conditions different to those indicated.

All materials used for manufacturing and packaging of the new equipment are ecological and or recyclable.

Directive 2012/19/EU (WEEE): Information for the users

This product is in compliance with the EU 2012/19/EU Directive.

The symbol of the crossed bin on the appliance indicates that the product, at the end of its life span, must be treated separately from household waste. It must be taken to a differentiated collection centre for electric and electronic appliances or taken back to the supplier on the purchase of a new equivalent appliance.







The user is responsible for taking the appliance to an appropriate collection centre at the end of its life span. Disposing of a household appliance separately avoids possible negative consequences for the environment and health deriving from inappropriate disposal and enables the constituent materials to be recovered to obtain significant savings in energy and resources.

For more detailed information regarding the collection systems available, contact the local waste disposal service or the supplier where the purchase was made.

1. Responsibility and recommendations

Safety procedures



Important information on safety is reported on the product and contained in this Manual. Carefully read this installation manual before installing the unit. Important information for correct installation is contained in the Manual.

MEANING OF THE SYMBOLS			
			
Indicates PROHIBITION	Indicates OBLIGATION	Indicates PRECAUTION (also dangerous/warnings)	CONNECT THE GROUND CABLE

MEANING OF THE INDICATION	
DANGER	ATTENTION
Indicates the risk of death or serious injuries <u>in the event of misuse.</u>	Indicates the risk of personal injury or damage to property, furniture or animals in the event of failure to follow the instructions.

1. Responsibility and recommendations

Safety Precautions

	Read the precautions in this manual carefully before operating the unit.
	This appliance is filled with R290.

- The precautions described herein are classified as WARNING and CAUTION. They both contain important information regarding safety. Be sure to observe all precautions without fail.
- Meaning of WARNING and CAUTION notices

⚠ WARNING.....Failure to follow these instructions properly may result in personal injury or loss of life.

⚠ CAUTION.....Failure to observe these instructions properly may result in property damage or personal injury, which may be serious depending on the circumstances.

- After completing installation, conduct a trial operation to check for faults and explain to the customer how to operate the heat pump and take care of it with the aid of the operation manual.

⚠ WARNING

- Ask your dealer or qualified personnel to carry out installation work.
Do not attempt to install the heat pump yourself. Improper installation may result in water leakage, electric shocks or fire.
- Install the heat pump in accordance with the instructions in this installation manual.
Improper installation may result in water leakage, electric shocks or fire.
- Be sure to use only the specified accessories and parts for installation work.
Failure to use the specified parts may result in the unit falling, water leakage, electric shocks or fire.
- Install the heat pump outdoors ensuring sufficient ventilation.
- Install the heat pump on a foundation strong enough to withstand the weight of the unit.
A foundation of insufficient strength may result in the equipment falling and causing injury.
- Electrical work must be performed in accordance with relevant local and national regulations and with instructions in this installation manual. Be sure to use a dedicated power supply circuit only.
Insufficiency of power circuit capacity and improper workmanship may result in electric shocks or fire.
- Use a cable of suitable length.
Do not use tapped wires or an extension lead, as this may cause overheating, electric shocks or fire.
- Make sure that all wiring is secured, the specified wires are used, and that there is no strain on the terminal connections or wires.
Improper connections or securing of wires may result in abnormal heat build-up or fire.
- If refrigerant gas leaks during installation, ventilate the area immediately.
There is a potential risk of explosion if the refrigerant comes into contact with fire.
- The refrigerant circuit contains flammable gas. All parts must be inspected and replaced by a licensed technician.

1. Responsibility and recommendations

WARNING

- Be sure to earth the heat pump.
Do not earth the unit to a utility pipe, lightning conductor or telephone earth lead. Imperfect earthing may result in electric shocks.
- Be sure to install an earth leakage circuit breaker.
Failure to install an earth leakage circuit breaker may result in electric shocks or fire.

CAUTION

- When Disposal of equipment must be performed in accordance with relevant local and national regulations.
- Do not use means to accelerate the defrosting process or to clean, other than those recommended by the manufacturer.
- Do not pierce or burn.
- Be aware that refrigerants has no odor.
- Make sure there is continuity of earth bonding.
- Replace components only with parts specified by the manufacturer.
- Do not use means to accelerate the defrosting process or to clean, other than those recommended by the manufacturer.
- Check that the staff wears suitable individual protection devices.
- Work in confined spaces shall be avoided.
- Ensure that the conditions within the area have been made safe by control of flammable material.
- The area shall be checked with an appropriate refrigerant detector prior to, during and after work, to ensure the technician is aware of potentially flammable atmospheres. Ensure that the leak detection equipment being used is suitable for use with flammable refrigerants, i.e. non sparking, adequately sealed or intrinsically safe.
- If any hot work is to be conducted on the refrigeration equipment or any associated parts, appropriate fire extinguishing equipment shall be available to hand.
- The area shall be checked with an appropriate refrigerant detector prior to, during and after work, to ensure the technician is aware of potentially flammable atmospheres. Ensure that the leak detection equipment being used is suitable for use with flammable refrigerants, i.e. non sparking, adequately sealed or intrinsically safe.
- Use non-sparking tools.
- Discharge static before beginning work.
- Notify the All persons in the vicinity of the system while work.
- If it is absolutely necessary to have an electrical supply to equipment during servicing, then a permanently operating form of leak detection shall be located at the most critical point to warn of a potentially hazardous situation.
- Under no circumstances shall potential sources of ignition be used in the searching for or detection of refrigerant leaks.
- This unit contains flammable refrigerant R290(safety groups A3). In the event of a leak, there is a risk of fire and explosion.
- R290 has a higher density than air. In the event of a leak, the leaked refrigerant may accumulate near the bottom.
- Refrigerant must only be disposed of by qualified personnel.
- If refrigerant be introduced the waste water system , there is a risk of fire and explosion.
- Do not load the unit. It may cause refrigerant to leak.
- In the event of a leak, Ventilate the room and turn off all sources of ignition.
- Have a dry powder or CO2 fire extinguisher adjacent to the charging area.
- All possible ignition sources, including cigarette smoking, should be kept sufficiently far away from the site of installation, repairing, removing and disposal, during which flammable refrigerant can possibly be released to the surrounding space.
- Prior to work taking place, the area around the equipment is to be surveyed to make sure that there are no flammable hazards or ignition risks.

1. Responsibility and recommendations

- Make sure the marking to the equipment continues to be visible and legible.
- “No Smoking” signs shall be displayed.
- Before performing any maintenance make sure you have removed the power acting on the switch.
- The extraordinary maintenance operations must be performed by qualified staff.
- The protective conductor connections should be checked according to the national rules and regulations each time a repair is made. The wiring and cabling should also be checked to make sure they are not damaged.
- Maintenance must be performed in accordance with relevant local and national regulations.
- Maintenance and repair requiring the assistance of other skilled personnel shall be carried out under the supervision of the person competent in the use of flammable refrigerants.
- Make sure the capacitors are discharged. This shall be done in a safe manner to avoid possibility of sparking.
- The extraordinary maintenance operations must be performed by qualified staff.
- Maintenance must be performed in accordance with relevant local and national regulations.
- If a defect is found, which puts the reliable operation of the refrigerating systems at risk, the installation should not be started up again.
- In the event of a leak, notify the customer and persons down wind of the leaking and keep unauthorized person out of the protected zone.
- The Heat pump contains refrigerant that requires special disposal.
- The HP unit must be taken to a relevant collection centre or the dealer, which will dispose of it correctly and suitably.
- Explain the safety warnings to the customer using the manual.
- Explain the risk of R290 refrigerant to the customer using the manual.

1. Responsibility and recommendations

When an anomaly is detected, as a burning smell, immediately stop the power supply by isolating on the main switch of the electrical panel.

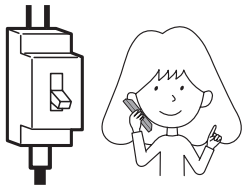

STRICT
ENFORCEMENT

This unit must not be used by children or people with reduced physical, sensory or mental capabilities, or lack of experience and knowledge, unless they are supervised.



CAUTION

Use the voltage 230V.



Do not use the power supply cable in a bundle.

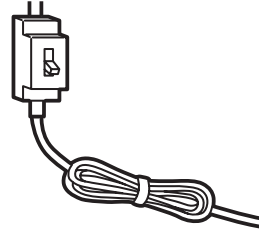

PROHIBITION

Take care not to damage the power supply cable.

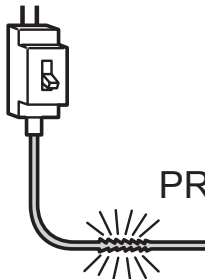

PROHIBITION

Do not insert objects into the air inlet or outlet.

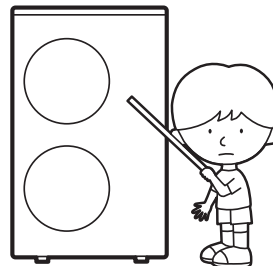

PROHIBITION

1. Responsibility and recommendations

Do not try to repair or reconstruct by yourself.

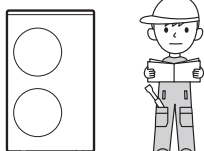

PROHIBITION

Do not extend power supply cable or connect incorrectly.



PROHIBITION

Connect the earth wire.

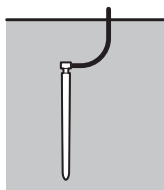

STRICT
ENFORCEMENT

Use an exclusive power source with a circuit breaker.

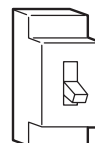

Do not climb, nor place any objects on the unit.

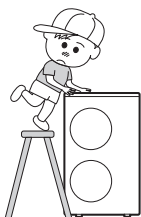

PROHIBITION

Do not allow the unit to be exposed to vapor or oil steam.



PROHIBITION

Do not stop the operation by turning off the circuit breaker.

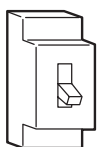

PROHIBITION

Check good condition of the installation stand.

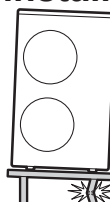

PROHIBITION

Do not pour water into the unit for cleaning.

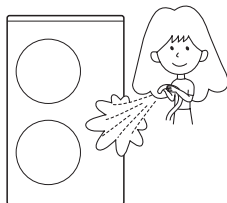

PROHIBITION

Do not place animals or plants in the direct path of the air flow.

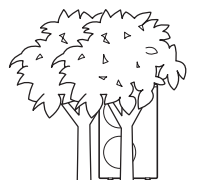

PROHIBITION

Note for draining water.







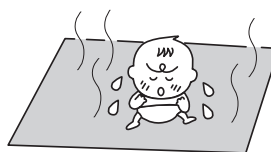

HIGH TEMPERATURE

The maximum temperature for the circulating water is approximately 75°C. Take care to avoid burns when draining the water.

1. Responsibility and recommendations

If the same part of the body is exposed to the floor heating for a long time, it could cause low temperature scalding.



	Check personnel wears suitable personal protective equipment.
	Verify the absence of damages caused by transport or movement of the equipment and, immediately forward the claim to the supplier.
	Dispose of the packing material in compliance with the local standards.
	Do not lift the unit by inserting hooks in the side handles but use specific equipment (lifting devices, trucks, etc.).
	Do not rest liquid containers or other objects on the unit.

- Do not use this unit for any purposes other than Heating and Cooling.
- This appliance can be used by children aged from 8 years and above and persons with reduced physical, sensory or mental capabilities or lack of experience and knowledge if they have been given supervision or instruction concerning use of the appliance in a safe way and understand the hazards involved. Children shall not play with the appliance. Cleaning and user maintenance shall not be made by children without supervision.
- The appliance is accessible to the general public.

2. Specifications

Model		AEYC-0649ZU-CH	AEYC-0849ZU-CH	AEYC-1249ZU-CH
Type	Heating and Cooling Monobloc Type DC Inverter (Reverse cycle)			
Power	1N ~ 230V 50Hz			
Heating (A7W35)				
Capacity	[kW]	6.0	8.0	12.0
Power Input	[kW]	1.31	1.70	2.45
Running Current (MAX.)	[A]	5.7(12.0)	7.4(16.6)	10.7(24.0)
COP		4.58	4.71	4.90
Heating (A-5W55)				
Capacity	[kW]	4.0	6.0	10.0
Cooling (A35W18)				
Capacity	[kW]	6.0	8.0	12.0
Power Input	[kW]	1.75	2.05	3.08
Running Current (MAX.)	[A]	7.6(9.6)	8.9(12.0)	13.3(15.4)
EER		3.43	3.90	3.90
MAX. Pressure	[MPa]	3.5		
Refrigerant (R290)	[kg]	0.50	0.85	1.15
Dimensions & Weight (NET)				
Height	[mm]	886	886	1,418
Width	[mm]	1,000	1,000	1,000
Depth	[mm]	330	330	330
Weight	[kg]	66	82	117
Temperature Range				
Outdoor Temperature				
Heating	[°C]	-20 to 45		
Cooling	[°C]	15 to 45		
Inlet Water Temperature	[°C]	18 to 65		
Water Pressure	[MPa]	0.1 to 0.3		

- Specifications are subject to change without notice.
- Acoustic Noise Information : According to EN 12102.
- If the air to water heat pump is operated under higher temperature conditions than those listed, the built-in protection circuit may operate to prevent internal circuit damage. Also, during Cooling modes, if the unit is used under conditions of lower temperatures than those listed above, it may freeze, leading to water leakage and other damage.

2. Specifications

Model		AEYC-0449ZU-CH1	AEYC-0649ZU-CH1	AEYC-1049ZU-CH1
Type	Heating and Cooling Monobloc Type DC Inverter (Reverse cycle)			
Power	1N ~ 230V 50Hz			
Heating (A7W35)				
Capacity	[kW]	4.0	6.0	10.0
Power Input	[kW]	0.87	1.23	2.02
Running Current (MAX.)	[A]	3.8(12.0)	5.3(16.6)	8.8(24.0)
COP		4.60	4.88	4.95
Heating (A-5W55)				
Capacity	[kW]	4.0	6.0	10.0
Cooling (A35W18)				
Capacity	[kW]	4.0	6.0	10.0
Power Input	[kW]	1.00	1.35	2.40
Running Current (MAX.)	[A]	4.3(9.6)	5.9(12.0)	10.4(15.4)
EER		4.00	4.44	4.17
MAX. Pressure	[MPa]	3.5		
Refrigerant (R290)	[kg]	0.50	0.85	1.15
Dimensions & Weight (NET)				
Height	[mm]	886	886	1,418
Width	[mm]	1,000	1,000	1,000
Depth	[mm]	330	330	330
Weight	[kg]	66	82	117
Temperature Range				
Outdoor Temperature				
Heating	[°C]	-20 to 45		
Cooling	[°C]	15 to 45		
Inlet Water Temperature	[°C]	18 to 65		
Water Pressure	[MPa]	0.1 to 0.3		

- Specifications are subject to change without notice.
- Acoustic Noise Information : According to EN 12102.
- If the air to water heat pump is operated under higher temperature conditions than those listed, the built-in protection circuit may operate to prevent internal circuit damage. Also, during Cooling modes, if the unit is used under conditions of lower temperatures than those listed above, it may freeze, leading to water leakage and other damage.

3. Installation

3.1 Notice for safety installation

CAUTION

- Please ask qualified installer to install this unit.
- Do not attempt to install this unit by yourself to avoid accidents such as electric shock, fire and leakage of water.
- Before installing this unit, please read this notice for safety installation carefully and install properly and safely.
- Be sure to follow the safety articles mention of important details on safety.
- After finishing the installation, please check no defective points in the testing operation. Then, kindly explain to the user about the directions and maintenance according to the operation manual.
- For product modification, the product and its specification may show slight differences from the description of this manual.

DANGER

- Be sure to install the unit in suitable place to hold the heavy weight. Lack of stability or imperfect installation may cause injury due to the fall unit falling.
- Do not install to a place where there is any possibility of inflammable gas leakage such as from LP gas cylinder around the unit. Leaked inflammable gas around the unit may cause a fire.
- If the leaked refrigerant is exposed to fire, there is a potential risk of explosion.
- The entry of other gases, such as air, into the cooling circuit could cause an explosion and injuries.

WARNING

- Connect the unit with standard parts required. This installation manual describes the correct connections using the installation set available from standard parts.

DANGER

- Installation work must be performed in accordance with national wiring standards by authorized personnel only.
- For the air to water heat pump to operate satisfactorily, install it as outlined in this installation manual.
- Also, do not use an extension cord.
- Do not turn on the power until all installation work is complete.
- Use designated parts or accessories to avoid accidents such as electric shock, fire and leakage of water.
- Follow the local standards in electric works. Be sure to use an exclusive power source.
- Any shortage of electric circuit's capacity or imperfect works may cause an electric shock and a fire.
- Never touch electrical components immediately after the power supply has been turned off. Electrical shock may occur. After turning off the power, always wait 5 minutes or more before touching electrical components.
- Be sure to fix the power supply cable in connecting points of the terminal block correctly, Imperfection of the connecting may cause overheating and a fire.
- Be sure to install the wiring lid in a straight line. Imperfect wiring works may cause overheating, a fire or electric shock at the connecting point in the terminal block.
- Always connect earth wire.
Never connect the earth cable to gas tube, water supply pipes, lightning rod and earth cable of telephone.
Imperfect earth connection may cause electric shock.
- Install a circuit breaker. Lack of circuit breaker may cause electric shock.

CAUTION

- Be sure to complete a drainage works according to this manual.
- After installation, check that there are no defects in the test. Then kindly inform the user about instructions and maintenance according to the user manual.

3. Installation

3.2 Positioning and securing

Dimensions

AEYC-0449ZU-CH1
 AEYC-0649ZU-CH
 AEYC-0649ZU-CH1
 AEYC-0849ZU-CH

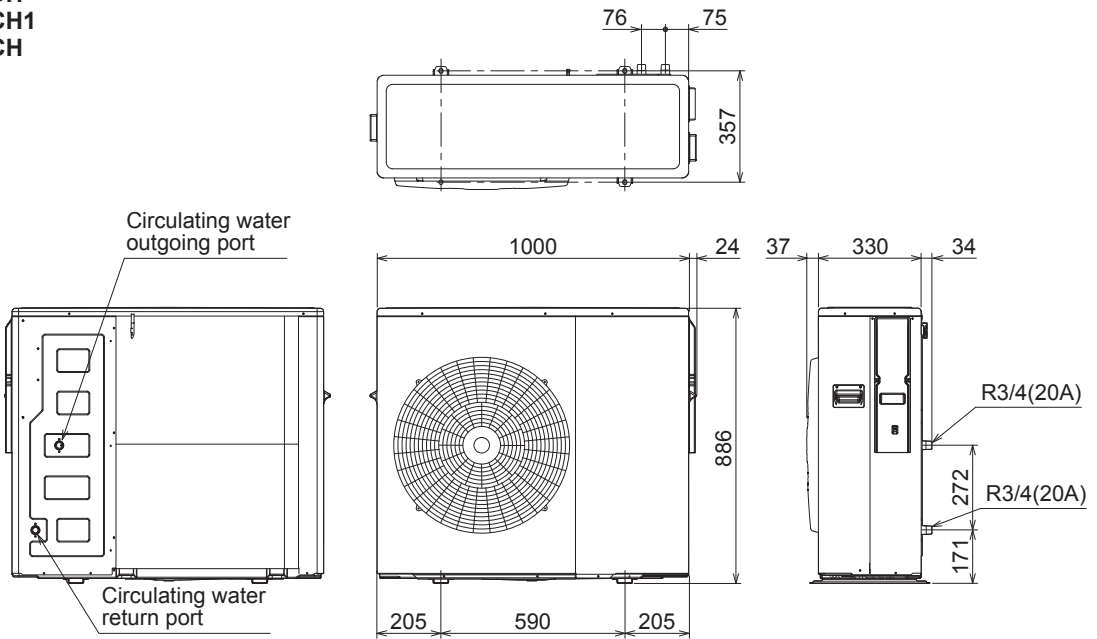

AEYC-1049ZU-CH1
 AEYC-1249ZU-CH

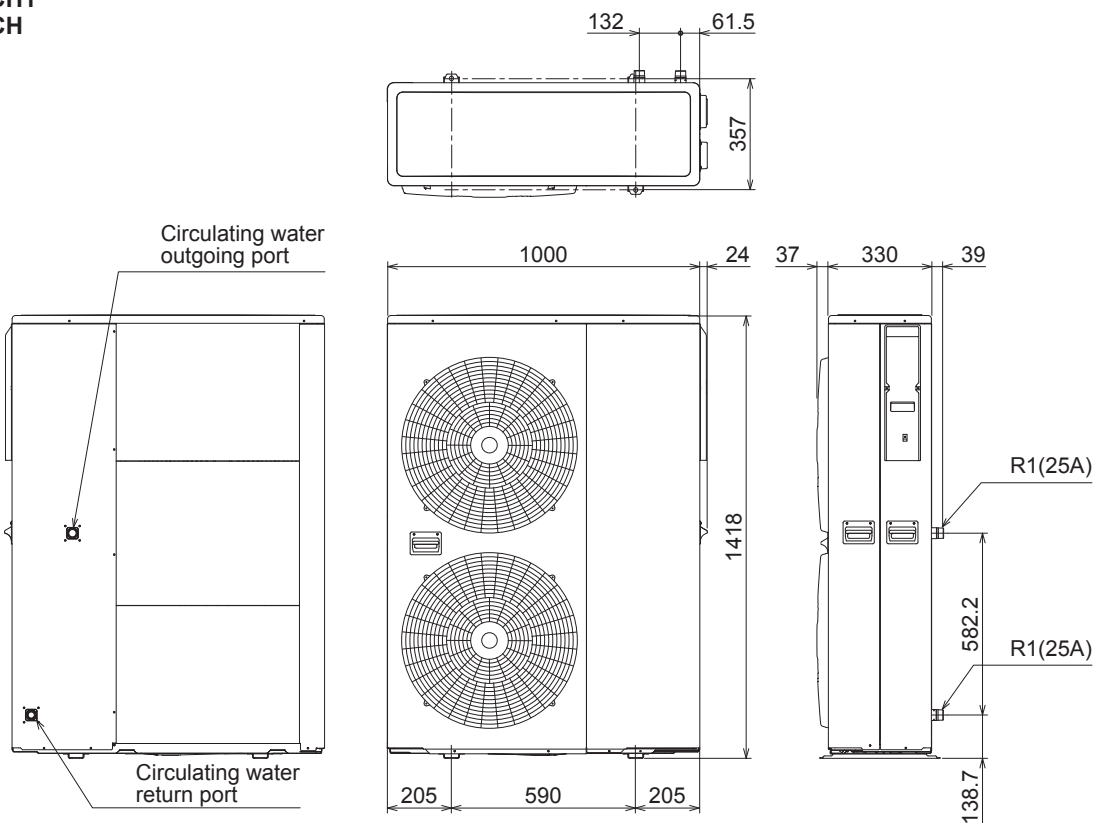

(Unit:mm)

3. Installation

- Anchor the unit to the concrete with bolts ($\varnothing 10$ mm) and nuts firmly and level.
- In case the vibration may affect the house, use an anti-vibration mounts and fix the unit securely.

Protect zone

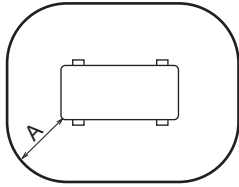

A 1000mm

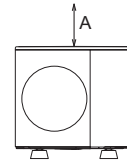

A 300mm

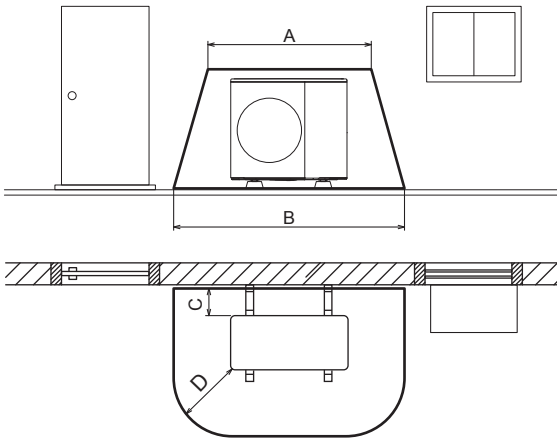

A 2000mm
B 3000mm
C 300mm
D 1000mm

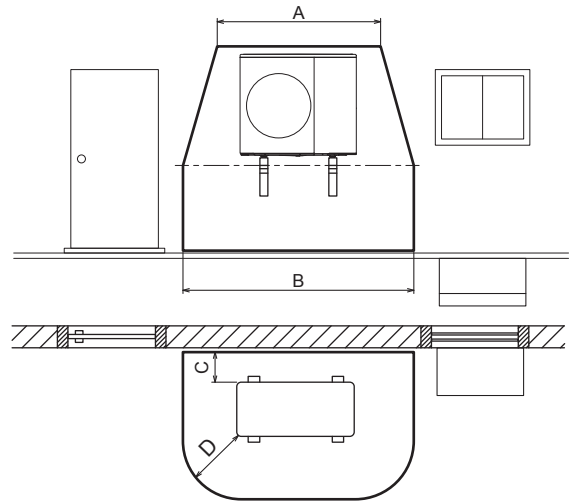

A 2000mm
B 3000mm
C 300mm
D 1000mm

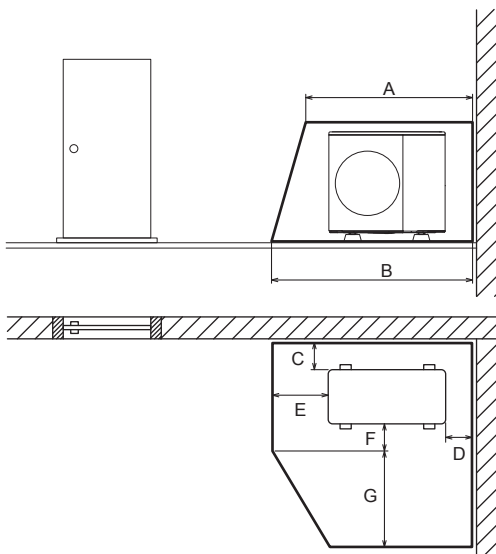

A 2000mm
B 2500mm
C 300mm
D 500mm
E 1000mm
F 500mm
G 1800mm

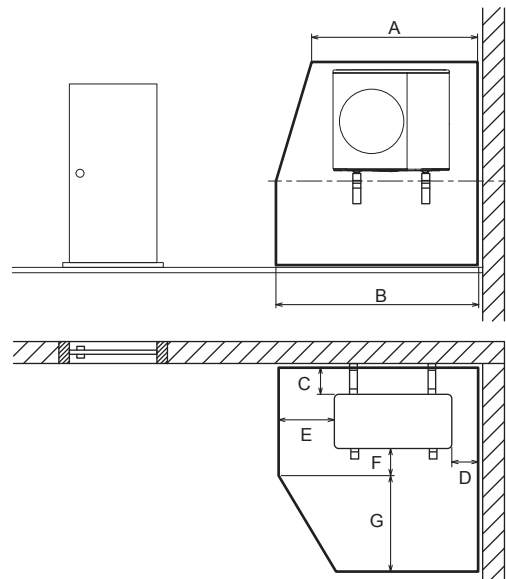

A 2000mm
B 2500mm
C 300mm
D 500mm
E 1000mm
F 500mm
G 1800mm

3. Installation

SELECTION ON THE PLACE

- Consider a place where the noise and the air discharged to not affect neighbours.
- Consider a position protected from the wind.
- Consider an area that respects the minimum spaces recommended.
- Consider a place that does not obstruct the access to doors or corridors.
- The surfaces of the floor must be solid enough to support the weight of the unit and minimise the transmission of vibrations.

DANGER

- Do not install where there is the danger of combustible gas leakage.
- If children may approach the unit, take preventive measures so that they cannot reach the unit.
- The unit must be installed level.

When installing the unit where it may be exposed to strong wind, brace it securely.

Decide the mounting position with the customer as follows:

- (1) Install the unit in a location which can withstand the weight of the unit and vibration. Please make sure it is installed level.
- (2) Provide the indicated space to ensure good airflow.
- (3) Do not install the unit near a source of heat, steam, or flammable gas.
- (4) During heating operation, condensate water flows from the unit. Therefore, install the unit in a place where the condensate water flow will not be obstructed.
- (5) Do not install the unit where strong wind blows or where it is very dusty.
- (6) Do not install the unit where people pass.
- (7) Install the unit in a place where it will be free from being dirty or getting wet by rain as much as possible.

CAUTION

- When the outdoor temperature is 0°C or less, remove the drain pipe and use without it. If the drain pipe is used, the drain water in the pipe may freeze in extremely cold weather.
- In the area with heavy snowfall, if the intake and outlet of unit is blocked with snow, it might become difficult to get warm and it is likely to cause of the breakdown. Please construct a canopy and a pedestal or place the unit on a high stand.
- There must be no ignition sources, such as plug sockets, light switches, lamps, electrical switches or other permanent ignitions sources, in the protective zone.
- There must be no open flames, heat above 360°C, in the protective zone.
- Do not use any sprays or other flammable gases in the protective zone.
- The protective zone must not extend to adjacent buildings or public traffic areas.
- In the protective zone, you are not permitted to make any subsequent structural alterations which infringe the stated rules for the protective zone.
- There must be no openings such as windows, doors, light shafts, cellar entrances, escape hatches, flat-roof windows or ventilation openings in the protective zone.

3. Installation

3.3 Main components

The heat pump has various safety parts and an internal circulator (Pump1) for quick installation with the aid of a few external components.

AEYC-0449ZU-CH1
AEYC-0649ZU-CH

Air inlet is located in the left or in the back

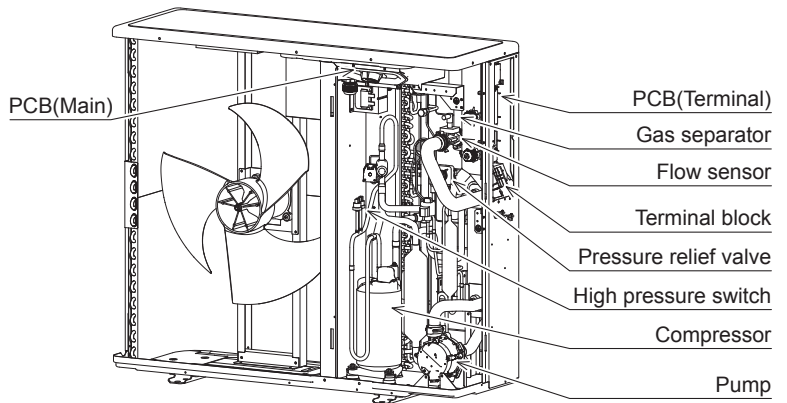
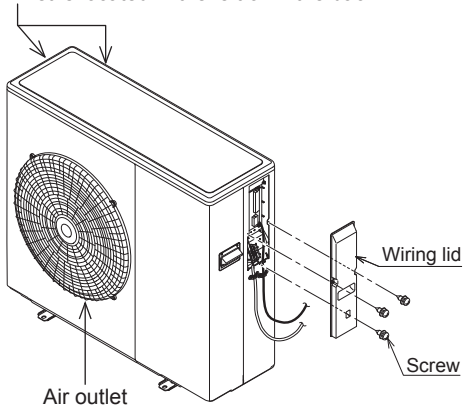

AEYC-0649ZU-CH1
AEYC-0849ZU-CH

Air inlet is located in the left or in the back

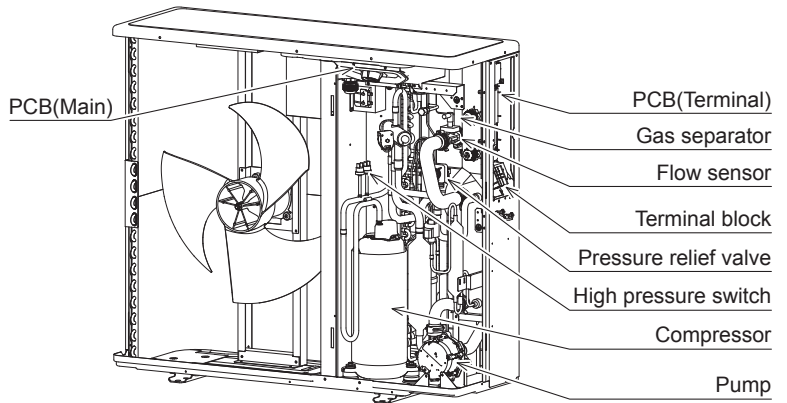
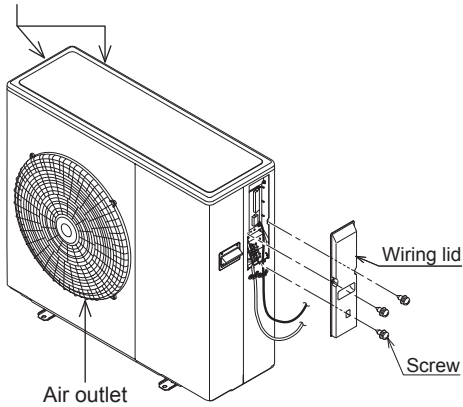

AEYC-1049ZU-CH1
AEYC-1249ZU-CH

Air inlet is located in the left or in the back

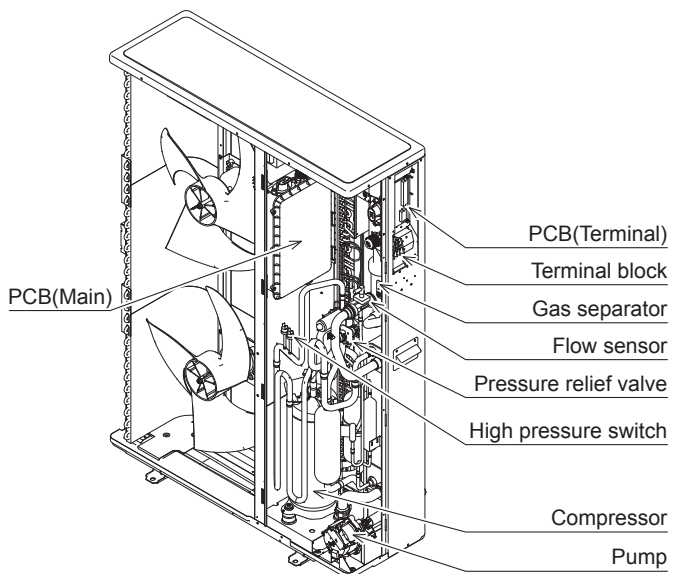
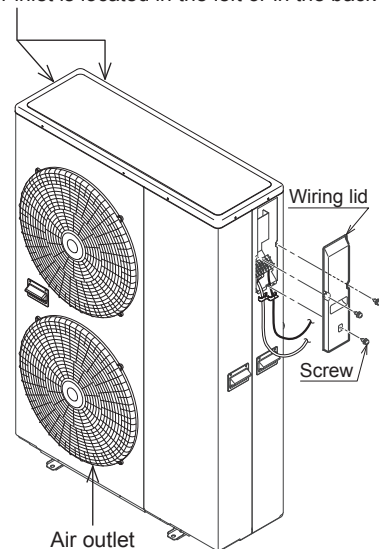

3. Installation

3.4 Pressures and quantity available at heat pump outlet

Main water pump in the unit has 3 levels of speed.

Factory default value is level 3.

Select dip switches 5 and 6 on the PCB(Terminal) to change the settings.

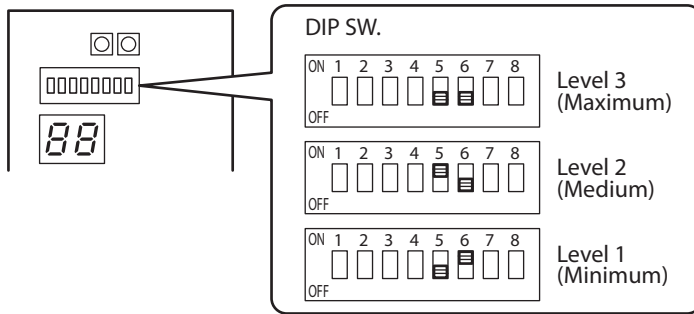

AEYC-0449ZU-CH1

AEYC-0649ZU-CH

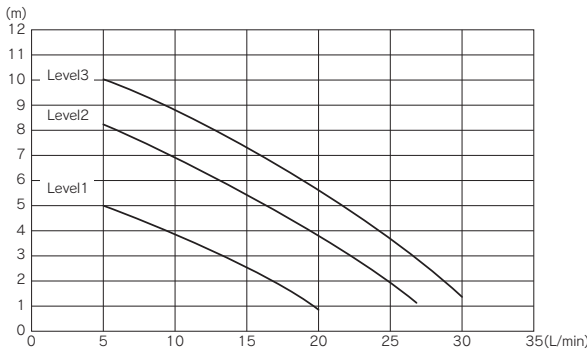

CAUTION

The quantity should not be less than 5L/min. Insufficient water flow may damage the water circulating circuit. If a flow rate becomes lower than the minimum flow rate, an alarm may go off, and a heat pump may stop operation to prevent damage to the unit.

AEYC-0649ZU-CH1

AEYC-0849ZU-CH

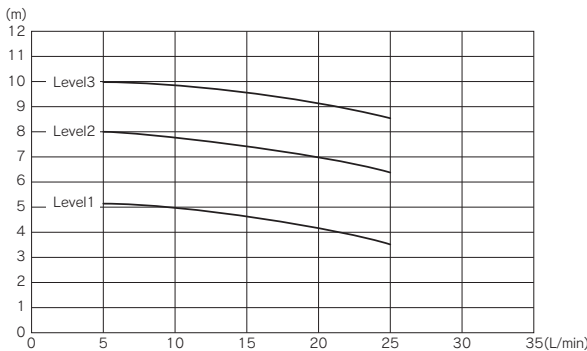

CAUTION

The quantity should not be less than 5L/min. Insufficient water flow may damage the water circulating circuit. If a flow rate becomes lower than the minimum flow rate, an alarm may go off, and a heat pump may stop operation to prevent damage to the unit.

AEYC-1049ZU-CH1

AEYC-1249ZU-CH

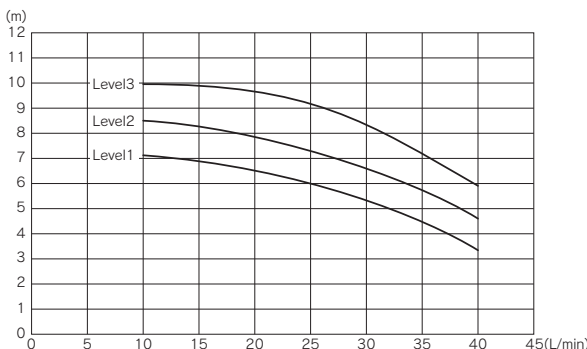

CAUTION

The quantity should not be less than 10L/min. Insufficient water flow may damage the water circulating circuit. If a flow rate becomes lower than the minimum flow rate, an alarm may go off, and a heat pump may stop operation to prevent damage to the unit.

3. Installation

3.5 Water circuit connection

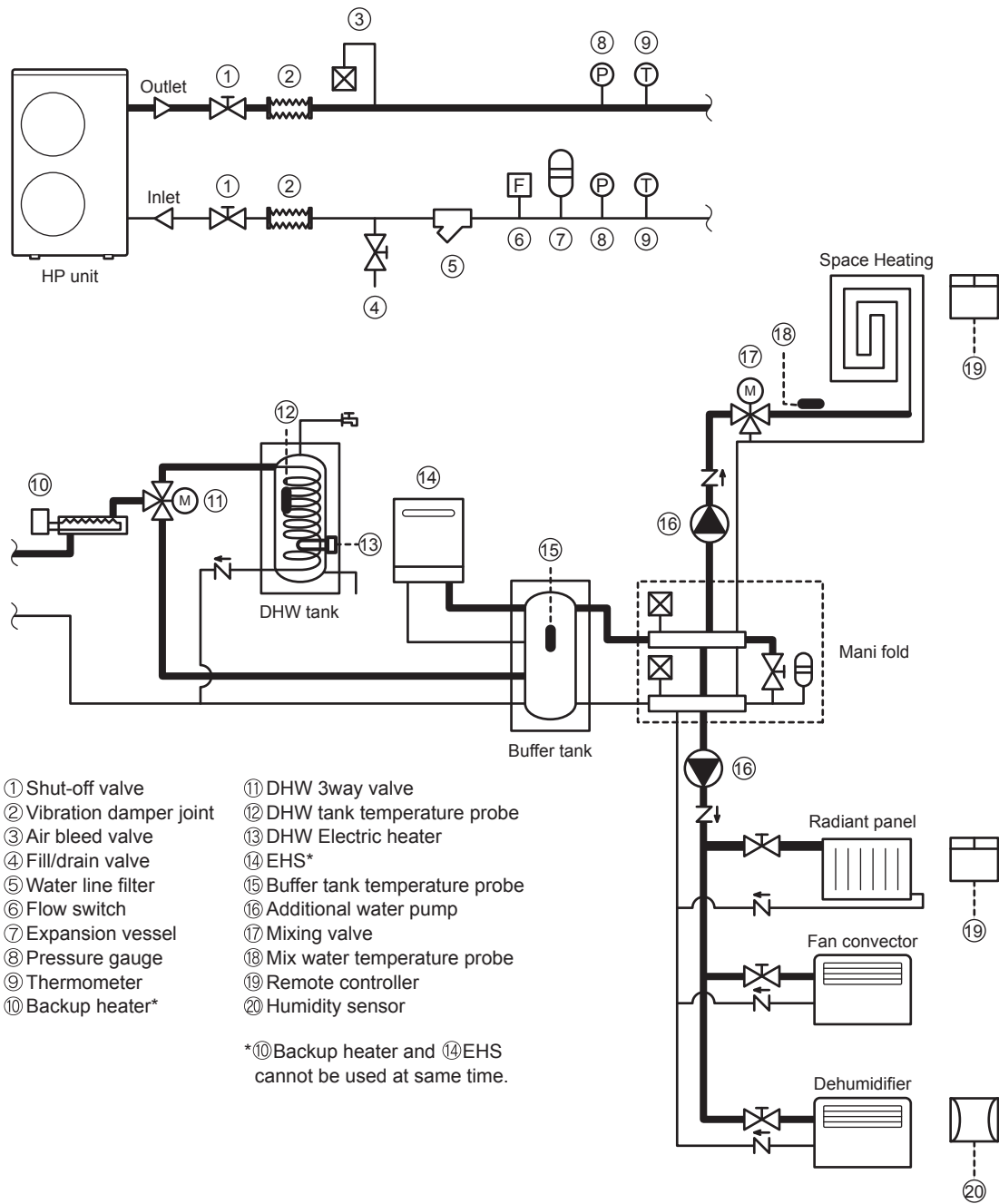

⚠ CAUTION

- The quantity of water in the system must not be less than 30 litres
- If the quantity of water in the system is higher than 160 litres, use an additional Buffer tank



Do not use the heat pump to treat industrial process water, swimming pool water or domestic water. Set-up an intermediate heat exchanger for all the above cases.

3. Installation

Additional pump

CAUTION

- When using an additional water pump, connect it according to "7.5.7 Additional water pump". Failure to do so may result in damage to the unit.

Anti-freeze function setting

If the circulation water is mixed with a certain quantity of inhibited glycol, then the anti-freeze function is not necessary.

To disable the anti-freeze function, access the PCB (Terminal) and set "Dip SW1" to OFF.

Remove the wiring lid to access the PCB (Terminal).

"Dip SW1" factory default setting is ON, so the anti-freeze function is enabled.

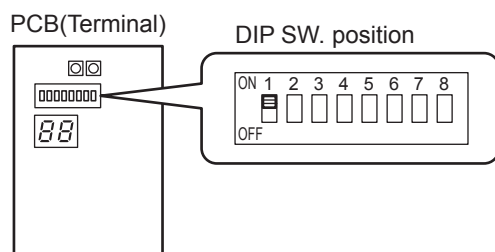

Hydraulic connections

The hydraulic connections of heat pump 01, must be carried out using all necessary components and completed with materials able to guarantee water seal of the threaded joints. The diagram typical of hydraulic circuit shows applications in the air conditioning field.

The hydraulic circuit must be completed following the recommendations below:

1. It is advised to include shut-off valves allowing isolation of the most important components of the system. These valves, that can be ball, globe or butterfly, must be dimensioned to allow the smallest load loss, possible when in opening position.
2. The system must have drainage in the lowest points.
3. Air vents must be included in the highest points of the system.
4. Gauges and pressure couplings must be installed upstream and downstream of the pump.
5. All piping must be adequately insulated and supported.
6. The presence of solid particles in the water can obstruct the heater. Therefore, protect the exchanger using a removable mesh filter. The gauge of the filter net must be of at least 10 meshes/cm².
7. After system assembly flush and clean the whole system, paying particular attention to the state of the filter.
8. In cases where water must be cooled at temperatures below 5°C, or if the device is installed in areas subject to temperatures below 0°C, it is essential to mix water with an adequate amount of glycol inhibitor.
9. In the event of new installation or emptying of the circuit, preventively clean the system. In order to guarantee good product operation, after every cleaning operation, water replacement or glycol addition, check the liquid is clear, without visible impurities and the hardness is below 20°.

3. Installation

Connection to the water circuit

- Water connections must be made in accordance with diagram in the manual and on the unit, respecting the water in-and outlet.

CAUTION

- Be careful not to deform the unit piping by using excessive force when connecting. Deformation of the piping can cause the unit to malfunction.

If air, moisture or dust gets in the water circuit, problems may occur. Therefore, always take into account the following when connecting the water circuit:

- Use clean pipes only.
- Hold the pipe end downwards when removing burrs.
- Cover the pipe end when inserting it through a wall so that no dust and dirt enter.
- Use a good thread sealant for the sealing of the connections. The sealant must be able to withstand the pressures and temperatures of the system.
- When using non-brass metallic piping, make sure to insulate both materials from each other to prevent galvanic corrosion.
- Because brass is a soft material, use appropriate tooling for connecting the water circuit. Inappropriate tooling will cause damage to the pipes.
- The unit is the only to be used in a closed water system. Application in an open water circuit can lead to excessive corrosion of the water piping.

Before continuing the installation of the unit, check the following points:

- The maximum water pressure is 3 bar.
- Make sure to provide a proper drain for the pressure relief valve to avoid any water coming into contact with electrical parts.
- Air vents must be provided at all high points of the system. The vents should be located at points which are easily accessible for servicing. An automatic air purge is provided inside the unit.
- Take care that the components installed in the field piping can withstand the water pressure.
- Never use Zn-coated parts in the water circuit. Excessive corrosion of these parts may occur as copper piping is used in the unit's internal water circuit.

3. Installation

NOTICE

- During filling, it might not be possible to remove all air in the system. Remaining air will be removed through the automatic air purge valves during first operating hours of the system. Additional filling with water afterwards might be required.
- The water pressure indicated on the manometer will vary depending on the water temperature (higher pressure at higher water temperature).
However, at all times water pressure should remain above 0.3 bar to avoid air entering the circuit.
- The unit might dispose some excessive water through the pressure relief valve.
- Water quality must be according to EN directive 98/83 EC.

Piping insulation

The complete water circuit, including all piping, must be insulated to prevent condensation during cooling operation and reduction of the cooling and heating capacity.

If the temperature is higher than 30°C and the humidity is higher than RH 80%, then the thickness of the sealing materials should be at least 20 mm in order to avoid condensation on the surface of the sealing.

Be sure to insulate the pipes in order to prevent the water being frozen.

Water loading and air bleeding in the hydraulic circuit

When Pump SW on the PCB (Terminal) is pressed, the water pump comes into operation to circulate water.

Each digital segment on the right side of the PCB (Terminal) lights up sequentially during pump operation.

The pump is stopped automatically after 10 minutes of operation. If air could not be released this way from the water circuit, then press Pump SW again after the pump has stopped. If you want to stop the pump before it stops automatically, press Pump SW again.

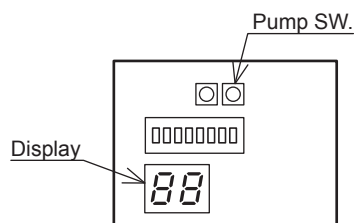

3. Installation

Attachment of drain elbow

- In case of using the drain elbow, attach it as illustrated.
- Do not attach the drain elbow in cold districts where the air temperature falls below zero continuously. Frozen drain ice may cause obstruction to the fan.

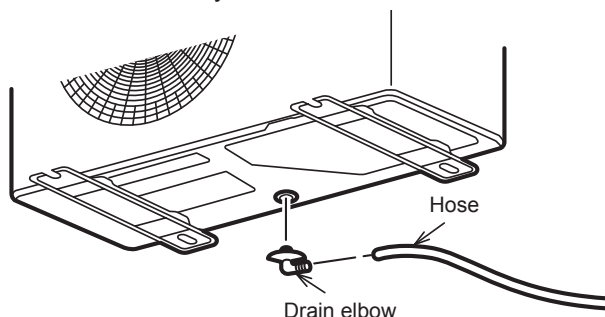

3.6 Electrical connections

All electrical connections made on site are solely the responsibility of the installer.

DANGER

Electrical shock may cause serious personal injury or death.
Electrical connections must only be performed by qualified personnel.

DANGER

- All cables and hydraulic components must be installed by a licensed technician and comply with all relevant European and national standards.
- Ensure the power supply system complies with the national safety standards in force.
- The electrical wiring must be carried out according to the wiring diagram supplied with the unit, and the instructions provided below.
- Turn off the power supply before making any connections.
- Ensure an effective grounding line is available.
- Be sure to use a dedicated electrical power supply system. Never use a power supply shared by another appliance.
- Check that the voltage and frequency of the electric system are those required.
- Ensure the impedance of the power supply line conforms to the electrical absorption of the unit specified on its data plate.
- It is necessary to incorporate a main switch in the fixed wiring or other means for disconnection having a contact separation in all poles, in accordance with relevant local and national legislation.
- Emergency disconnect devices from the mains must allow for disconnection in accordance with the conditions of overvoltage protection class III.
- Make sure to install a protective earth leakage device (30 mA). Failure to observe this warning may cause electric shock.
- Make sure to establish a grounding line. Do not ground the unit by connecting it to a service pipe, a voltage absorber or a phone line grounding block. Incomplete grounding may cause electric shock.
- Do not change the unit by removing safety devices or by-passing safety switches.

ATTENTION

- Properly connect the connecting cable to prevent damage to electrical components.
- Connection to the mains is of Y type, thus replacing the cable should only be done by the technical service in order to prevent harm.
- For wiring, use specific cables and firmly connect them to terminals.

3. Installation

CAUTION

AEYC-0449ZU-CH1, AEYC-0649ZU-CH

- The unit complies with Voltage Fluctuations and Flicker (EN61000-3-3).
- The unit complies with Harmonic Current Emission (EN61000-3-2).

AEYC-0649ZU-CH1, AEYC-0849ZU-CH, AEYC-1049ZU-CH1, AEYC-1249ZU-CH

- The unit complies with Voltage Fluctuations and Flicker (EN61000-3-3).
- The unit complies with Harmonic Current Emission (EN61000-3-2, 3-12).

Removing the wiring lid will give access to the electrical power supply terminal board of the heat pump and the PCB (Terminal) for the external contacts and sensors connection.

WARNING

- The rated voltage of this product is 230 V a.c. 50 Hz.
- Before turning on, verify that the voltage is within the 207 V to 253 V range.
- Always use a dedicated circuit and install a dedicated receptacle to supply power to the air to water heat pump.
- Use a dedicated circuit breaker and receptacle matched to the capacity of the air to water heat pump. (Install in accordance with standard.)
- Perform wiring work in accordance with standards so that the air to water heat pump can be operated safely and positively.
- Install a dedicated leakage circuit breaker in accordance with the related laws and regulations and electric company standards.
- The circuit breaker is installed in the permanent wiring. Always use a circuit that can trip all the poles of the wiring and has an isolation distance of at least 3 mm between the contacts of each pole.

CAUTION

- The power source capacity must be the sum of the air to water heat pump current and the current of other electrical appliances. When the current contracted capacity is insufficient, change the contracted capacity.
- When the voltage is low and the air to water heat pump is difficult to start, contact the power company to raise the voltage.

3. Installation

Be sure to use an exclusive power source with a circuit breaker.

Respecting the following designation, use cables whose wires size are more than the designated one in the table below.

Power cord and circuit breaker shall be approved according to EN standard.

Supply cord must be approved in compliance with IEC60245 IEC57 (H05RN-F).

Model	Min. power supply cord(mm ²)	Breaker capacity
AEYC-0449ZU-CH1 AEYC-0649ZU-CH	1.5	16
AEYC-0649ZU-CH1 AEYC-0849ZU-CH	2.5	20
AEYC-1049ZU-CH1 AEYC-1249ZU-CH	2.5	25

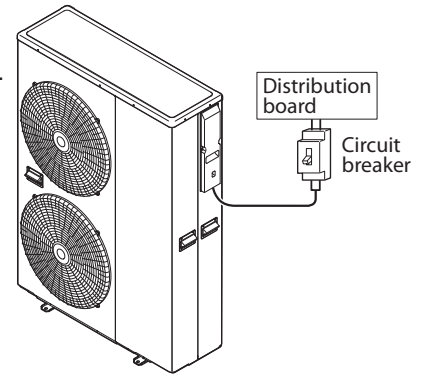

Peel ends of connecting cables in accordance with dimension in the diagram.

Use crimp-on terminals with insulating sleeves as illustrated in the diagram below for connecting the wires to the terminal block or PCB(Terminal).

Stranded conductors shall not be soldered.

- Use a circuit breaker with a 3 mm clearance of air gap between the contacts.

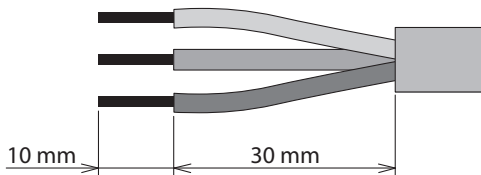

Stripped wire :10mm

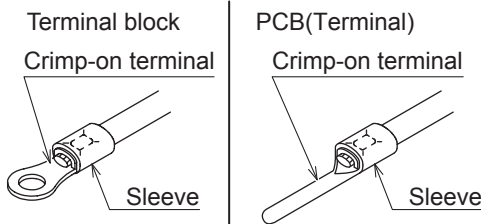
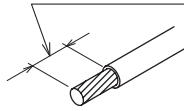

- Be sure to insert the cable cores into the proper position of the terminal block completely.
- Faulty wiring may cause not only abnormal operation but also damage to pc board.
- Fasten each screw sufficiently.
- To check the complete insertion, pull the cable slightly.

※Swage the rod terminal of a lead to wire. Do not solder a lead, or it may cause a fire.

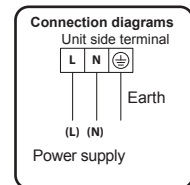
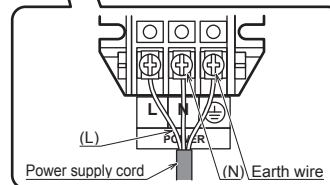
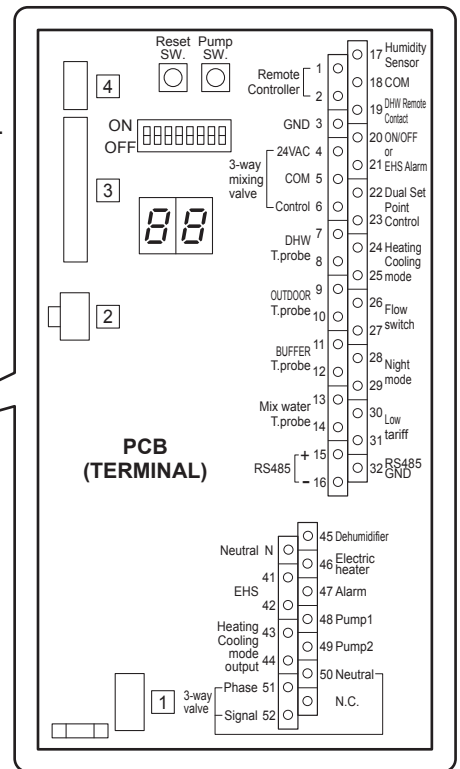

⚠ CAUTION

Peeling of the connecting cable's covering must be 10 mm.

If shorter, a defective contacting may occur.

If longer, a short circuit may occur.

Faulty or incomplete "Neutral (N)" wiring may lead to a breakdown.

3. Installation

WARNING

- Before starting work, check that power is not being supplied to the controller and outdoor unit.
- Match the terminal board numbers and connection cord colors with those of the outdoor unit. Erroneous wiring may cause burning of the electric parts.
- Connect the connection cords firmly to the terminal board. Imperfect installation may cause a fire.
- Always fasten the outside covering of the connection cord with the cord clamp. (If the insulator is chafed, electric leakage may occur.)
- Always connect the ground wire.
- If the supply cord is damaged, it must be replaced by the supplier, its service agent or similarly qualified persons in order to avoid a hazard.

CAUTION

- Match the terminal block numbers and connection cord colors with those of the controller. Erroneous wiring may cause burning of the electric parts.
- Connect the connection cords firmly to the terminal block. Imperfect installation may cause a fire.
- Always fasten the outside covering of the connection cord with the cord clamp. (If the insulator is chafed, electric leakage may occur.)
- Securely earth the power cord plug.

Tightening torque	
M4 screw	1.2 to 1.8 N·m (12 to 18 kgf·cm)
M5 screw	2.0 to 3.0 N·m (20 to 30 kgf·cm)

WARNING

Use crimp-type terminals and tighten the terminal screws to the specified torques, otherwise, abnormal overheating may be produced and possibly cause extensive damage inside the unit.

CAUTION

When connecting the power supply cord, make sure that the phase of the power supply matches with the phase of the terminal board.

WARNING

- A main switch or other means for disconnection, having a contact separation in all poles, must be incorporated in the fixed wiring in accordance with relevant local and national legislation.
- Switch off the power supply before making any connections.
- All field wiring and components must be installed by a licensed electrician and must comply with relevant European and national regulations.
- The field wiring must be carried out in accordance with the wiring diagram supplied with the unit and the instructions given below.
- Be sure to use a dedicated power supply. Never use a power supply shared by another appliance.
- Be sure to establish an earth. Do not earth the unit to a utility pipe, surge absorber, or telephone earth. Incomplete earth may cause electrical shock.
- Be sure to install an earth leakage protector (30 mA). Failure to do so may cause electrical shock.

3. Installation

3.7 Remote controller

- The connection between the equipment and the Remote controller is low-voltage circuit work, so it does not require electrician qualifications, but do follow technical standards for electrical equipment in making this installation.
- Isolate the main power supply for the unit before connecting the Remote controller cord.

Notes for the Remote controller installation

- Do not install the Remote controller in moist conditions such as in the bathroom. The Remote controller is not waterproof.
- Keep the distance of 1cm or more between the surrounding wall and another Remote controller in order for the cover of the Remote controller to touch any obstacles when it is open fully.
- Never install above a gas stove or burner or any other combustion device. This would cause breakdown of electrical parts and deformation of the outer case.
- Do not install in any location subject to steam from a rice cooker, crock pot, or the like, subject to water, or subject to spray from a faucet.
- Do not install in any location subject to direct sunlight.
- Install the Remote controller in the position where it can detect the room air temperature properly without any impact of heat by other space heaters or lighting switch with dimming function.
- Keep it out of the reach of children.
- It is convenient if the Remote controller is installed in the same room as the floor heating.
- Do not install in any location where industrial chemicals are used (ammonia, sulfur, chlorine, ethylene compounds, acids, etc.)
- Install the Remote controller cord in the position without any impact of heat.
- Do not damage the Remote controller cord and use cable duct to avoid the damage when it is embedded.

1. Installing the Remote controller

1. Slide the mounting plate downward to take out from the Remote controller.

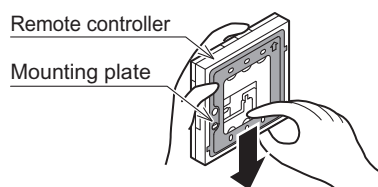

2. Fix the mounting plate to the wall.

When the wiring is embedded

- ① Before starting the Remote controller installation, pass the wiring conduit through the inside of the wall and install the wiring box.

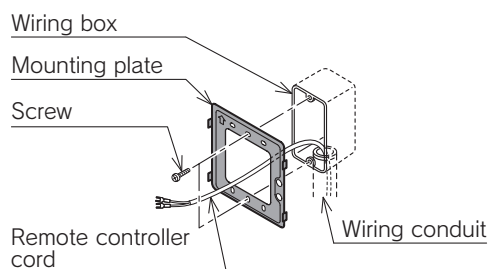

- ② Pull out the Remote controller cord, passing it through the wiring conduit and through the wiring hole in the mounting plate.
- ③ Line up the mounting plate with the holes for the wiring box mounting screws (M4 x L35, 2 screws) and fasten it with those screws. If you tighten the screws too far, this can deform or break the mounting plate and make it impossible to install the Remote controller.

3. Installation

When the wiring is exposed

Fix the mounting plate to the solid position of the wall with the attached tapping screws (L35, 2 screws).

• If you tighten the screws too strongly, this can deform or break the screw hole of the mounting plate.

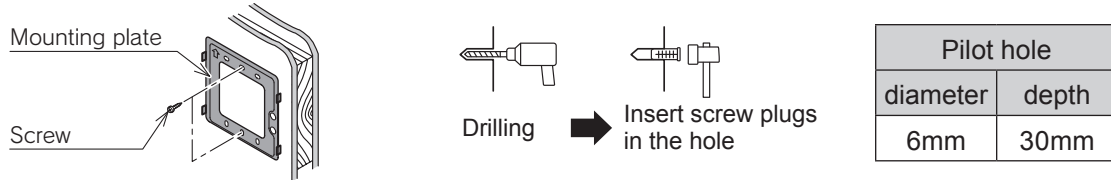

*Use the attached screw plugs if the mounting plate is fixed by screws to tile, concrete, and mortar wall.

3. Connect the Remote controller cord to the Remote controller.

① Install Y-shaped terminal to end of the Remote controller cord.

• The Remote controller cord is non-polar, so with no + or -.

② Connect Y-shaped terminal to the Remote controller terminal firmly, and hook the Remote controller cord to the wires clamp.

When the wiring is embedded

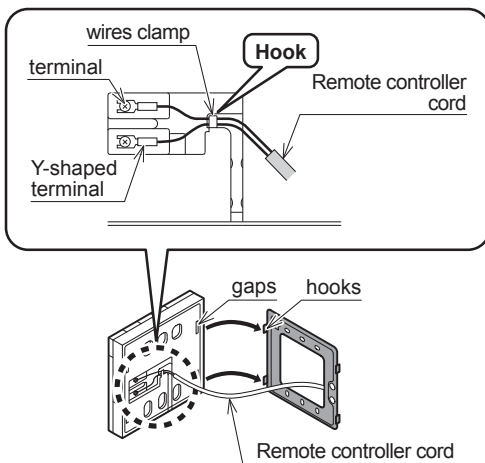

When the wiring is exposed

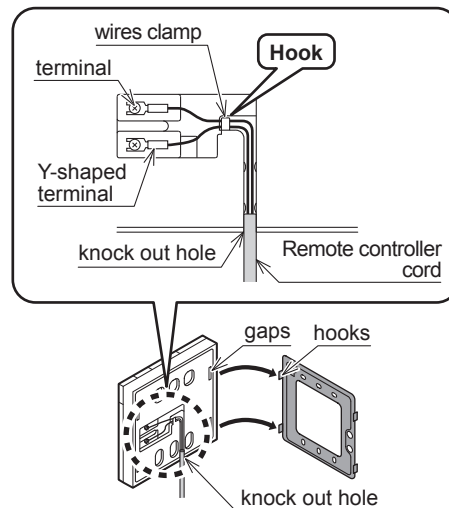

- Do not damage the PCB of Remote controller with too much pressure when the terminal is installed.
- Never use electric screwdriver. It can damage the screw hole which cause contact failure.

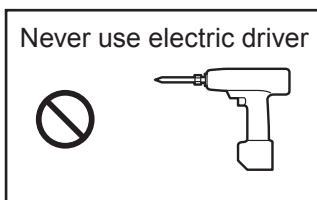

4. Install the Remote controller.

Fix the Remote controller to the mounting panel by sliding it from upward to downward with the 4 gaps on the backside of the Remote controller fit to the hook of the mounting panel.

5. After installing the Remote controller, check the fixing condition.

If the mounting panel is not stable, tighten the screws further.

3. Installation

2. Connecting with the equipment

1. Isolate the mains power supply for the unit from the power source.
Do not connect the Remote controller cord with the power on.
2. Remove the wiring lid.
3. Connect the Remote controller cord to the PCB(Terminal), No.1-2 (Remote Controller). It does not matter which wire of the Remote controller cord is connected to + and which to -. Take care not to let your screwdriver etc. touch any of the other electronic parts. Do not use a power driver. It can damage the terminal screw holes.
4. If shielded wire is used, connect it to Terminal No.3(GND) on the PCB(Terminal).
5. Securely fasten the Remote controller cord with the cord fastening fitting. Leave the display board waterproofing cover removed.

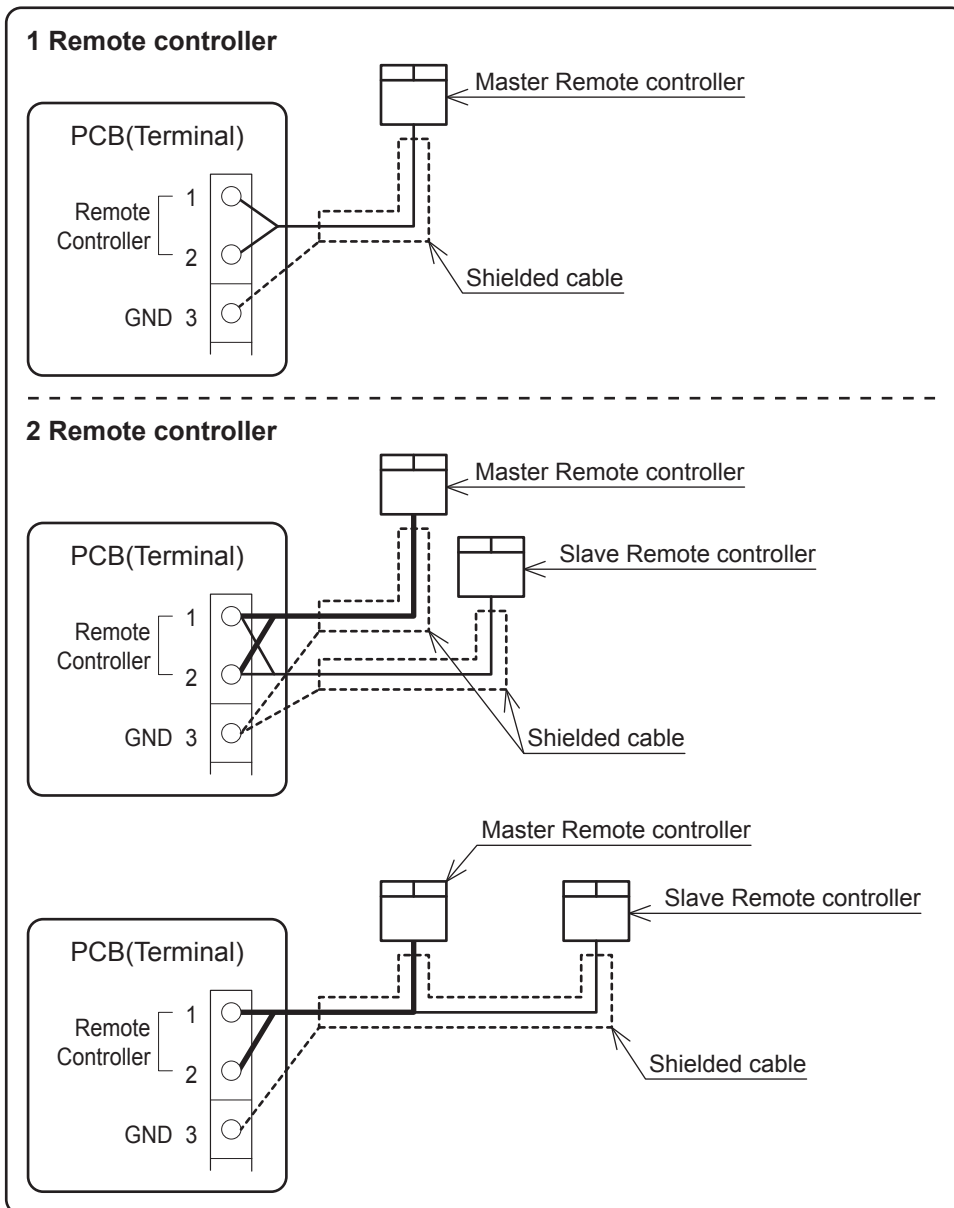

- The maximum length of the Remote controller cord is 100m.
Use shielded wire in case of the length with 30m or longer.
Connect the shielded wire to Terminal No.3(GND) on the PCB(Terminal).

Distance	Cable(mm ²)	Shield
~30m	MIN 0.5	non-shielded
30~100m	MIN 1.0	shielded

3. Installation

3. Master and Slave setting

2 Remote controllers can be connected by 1 Master Remote controller (for Zone1) and 1 Slave Remote controller (for Zone2).

Switch the Dip switch button on the back side.

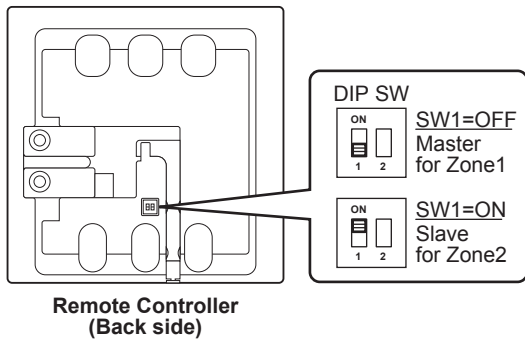

Note1: Communication error will occur if 2 Master Remote controllers and 2 Slave Remote controllers are connected.

Note2: Slave Remote controller functions can be used when Master Remote controller is not connected. However, parameter setting, ON/OFF of DHW, or time setting and so on cannot be set and changed by Slave Remote controller.

Dimensions



4. Remote Controller

4.1 Buttons

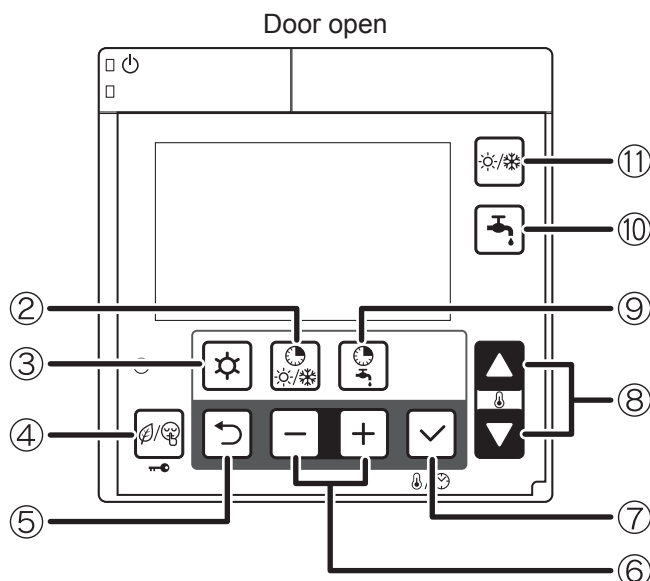
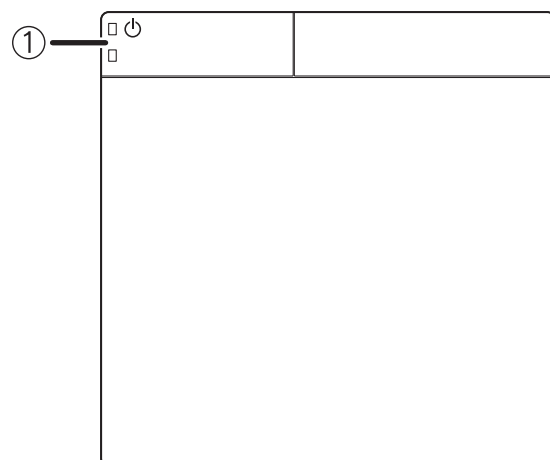

No.	Button name	Description
1	ON/OFF	Push the button for 3 seconds to turn ON and turn OFF the HP unit. Turn on the LED(green) of ON/OFF button if the HP unit is ON. The LED(red) of the ON/OFF button blinks when an alarm on the heat pump occurs.
2	Timer for Heating/Cooling	Push the Timer for Heating/Cooling button to change ON/OFF the time bands for Heating/Cooling. If the time bands, day and clock have not been set, it will not be available and decline this operation. Push the Timer for Heating/Cooling button for 3 seconds to set ON/OFF of the time bands for Space Heating/Cooling. The time bands can be programmed by selecting each individual day or in groups (7 days, 5 working days, 2 holidays) for room set temperature of Comfort or Economy and its time respectively. *Slave Remote controller only can set ON/OFF of the time bands but cannot set the time as the long press is not available. The time can be set by Master Remote controller.
3	Menu	Programming: dedicated button for accessing the menu/parameters. Push the Menu button for 3 seconds to set the parameters (user level).
4	Timer for Low tariff/Night (Key Lock)	Push the Low tariff/Night button to set HP unit operation mode. Low tariff → Night → Low tariff and Night → OFF the mode ↑ Push the Low tariff/Night button for 3 seconds to lock the button. During Key Lock is active, push 3 seconds to unlock. (Also during Key Lock is active, it is possible to only turn OFF the HP unit by the ON/OFF button.)
5	Return	Return button in parameter programming mode. Push the Return button for 3 seconds to enter the monitor display mode.
6	-, +	For parameter setting, select and change the digit to be entered. Push the Menu,-,+ button together for 3 seconds to set the parameters (installer level). During alarm display, push - and + button of Master Remote controller together for 3 seconds to reset alarm display.
7	Set(confirm)	Push the Set button: -During the programming to save the setting. -Change display : Clock→Humidity value (*) →Room set temperature ↑ (*)Humidity value is displayed only Master Remote controller, when Par5117 (Humidity sensor) set enable, if the parameter set disable, humidity value is not displayed (skip). Push the Set button for 3 seconds to set the current time (day, hour, minutes). Time setting can be set by Master Remote controller only.
8	Up,Down	Selecting the room set temperature. Even when the clock is displayed, press the Up or Down button to change to select the Room air temperature. For parameter setting, change the parameter numbers.
9	Timer for DHW	Push the Timer for DHW button to change ON/OFF the time bands for DHW. Push the Timer for DHW button for 3 seconds to set the time bands for DHW. If the time bands, day and clock have not been set, it will not be available and decline this operation.
10	DHW	Domestic Hot Water production: - Push the DHW button: DHW time band disable : DHW Comfort → DHW Economy → DHW OFF DHW time band active: Disable. - Push the DHW button for 3 seconds: Start DHW force mode, to charge the DHW tank until it reaches the over boost set point. Press for 3 seconds again to escape force mode. In case of "only HP" (without DHW heater), DHW tank is heated to reach comfort set point even in DHW force mode.
11	Mode	Selecting the operating mode. -Heating/Cooling time band disable : Heating/Cooling OFF→Heating→Cooling -Heating/Cooling time band active : Heating↔Cooling

4. Remote Controller

4.2 Display panel

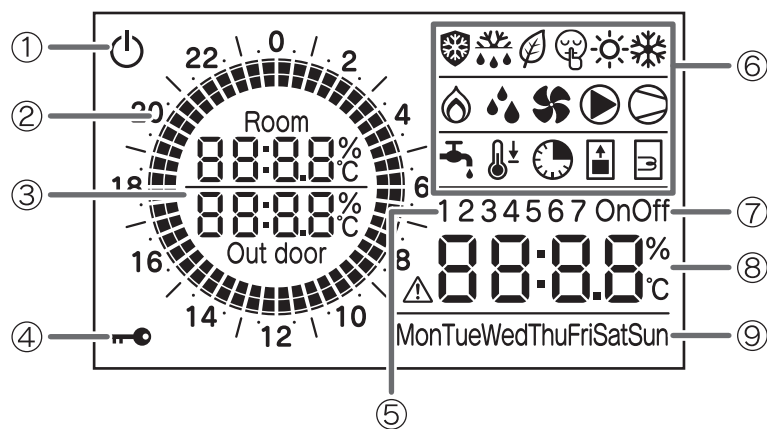

• Backlight display

- Turn ON : Door of Remote controller open.
- Turn OFF: Door of Remote controller closed.
Even if the door is still open, no operation of buttons for 60 seconds.

No.	Icons	Description
1		Power is ON, but ON/OFF switch is OFF (the unit is stopped)
2		Indicate ON/OFF on Comfort/Economy schedule of time band setting by Circle graph A block is that divided 1 hour to 4 blocks every 15 minutes
3		Room air temperature, Outdoor temperature
4		Key lock is active
5	1 2 3	Display in time band setting
6		Frost protection is active
		Defrost cycle is active
		Low tariff mode is enabled
		Night mode is enabled
		Heating mode is enabled Flashing: In Heating mode, Heating is stopped for production of DHW
		Cooling mode is enabled Flashing: In Cooling mode, Cooling is stopped for production of DHW
		EHS or Backup heater active
		Dehumidifier is active
		Outdoor fan is active
		System pump is active
		Compressor active Flashing: compressor delay
		DHW production of "Comfort mode" is enabled Flashing: In DHW mode, DHW production is stopped for Heating/Cooling
		DHW production of "Economy mode" is enabled
		Time bands for DHW is enabled(Displayed together with DHW Comfort or Economy icon)
7	OnOff	Time band is active/enable To set the time bands, it indicates ON time/OFF time
8		Display alarm icon, and indicate error code Clock, Room set temp, Humidity value, Parameters value
9	MonTueWedThuFriSatSun	Day of the Week

5. Operation and functions of the Remote controller

5.1 System ON/OFF

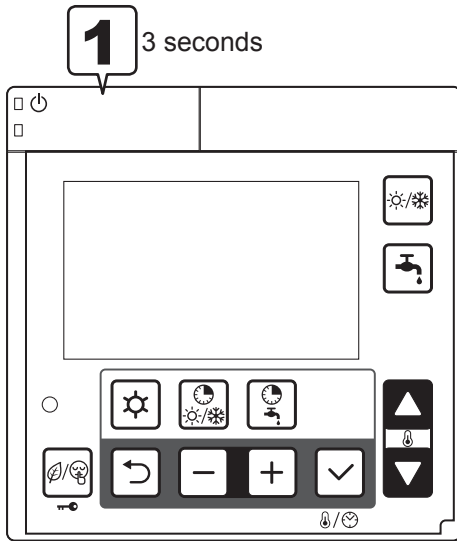

- 1 Press ON/OFF switch for 3 seconds to turn ON/OFF the system.
LED (green) of ON/OFF switch is lit when the system is ON.

〈System OFF→ON〉

The unit starts in the operation mode with the condition at the point of the last OFF of the system.

*However, the operation mode is based on the time band setting if it is available.

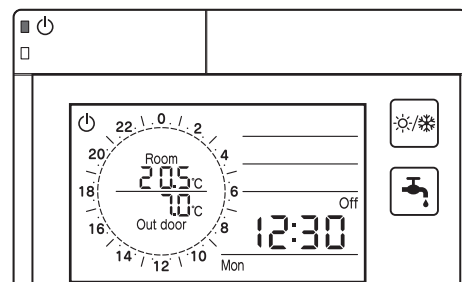

〈System ON→OFF〉

The operation is stopped.

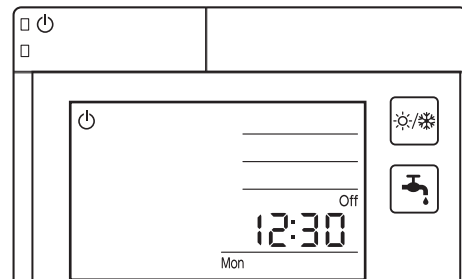

Note: In recovering from blackout, the HP unit will operate as below depending on the condition before the blackout;

The last operating condition before the blackout,

- If ON/OFF switch is OFF, the unit will recover from the blackout in OFF state.
- If ON/OFF switch is ON, the unit will recover from the blackout in the last operating mode before the blackout.

*However, the time band operation is not available if the blackout lasts 24 hours or more and the clock is reset.

5. Operation and functions of the Remote controller

5.2 Setting the day and time

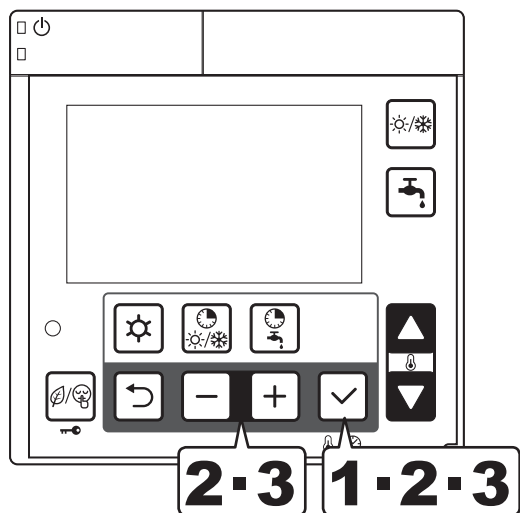

- 1** Press the Set button for 3 seconds.
- 2** The day 'Mon' indicator will blink. (*)
Select the day by pressing - or + button, and press Set button to save the setting.
The display of the day of the week changes blinking to lighted.

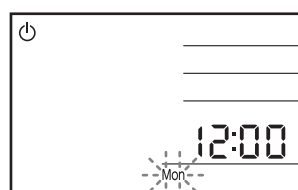

- 3** When the day of the week is set, "12:00" blinks; set the current time by pressing the - or + button. (*)
When the - or + button is pressed, the time changes in 1-minute increments; when the - or + button is pressed and held, it changes in 10-minute increments.

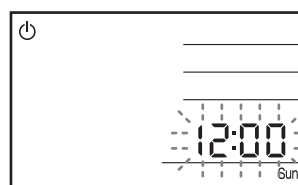

When the Set button is pressed to save the setting, then it reverts to normal operation.

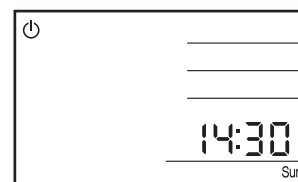

(*) When the time has already been set, the current setting of day and time will flash.

5. Operation and functions of the Remote controller

Note: The accuracy of the clock is ± 30 second/month.

If the main power turns OFF due to a power failure, etc., the time function is maintained for approximately 24 hours. Therefore, the time and day of the week settings are not required when the power turns ON again. If a power failure continues over 24 hours, the time and day of the week setting must be specified again.

- After installation and before setting the time or when the unit is reset after a power failure or after the power had been turned OFF for an extended period of time; if the time has not been set, 12:00 and Mon blink, indicating that the time has not yet been set.
- The time band operation (Heating/Cooling, DHW) can be carried out only once the current time has been set. Heating/Cooling by Mode button, DHW production by DHW button, and operating by external switches connected to PCB (Terminal), can be used without setting the current time.
- The time and day of the week settings are carried out using the Master Remote controller. The Slave Remote controller cannot be used for this setting.
- When Set button is pressed to set “minutes”, “seconds” will be reset and start its count from “0 second”.

Parameter

Level	Parameter		Function description	Display & Input value				Remarks
	Group	Code		Default	min.	Max.	Unit	
U	01	14	Day 0=Monday, 1=Tuesday, 2=Wednesday, 3=Thursday, 4=Friday,5=Saturday, 6=Sunday	0	0	6	-	
U	01	15	Clock	12:00	0:00	23:59	1min	

5. Operation and functions of the Remote controller

5.3 Selecting the operating mode

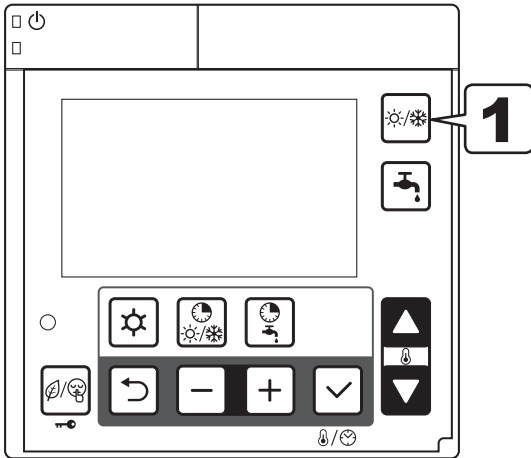

1 Press the Mode (Heating/Cooling) button to select Heating/Cooling mode.

-Heating/Cooling time band disable :
Heating/Cooling OFF → Heating → Cooling

Heating/Cooling OFF

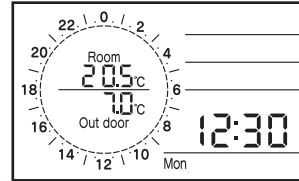

Heating

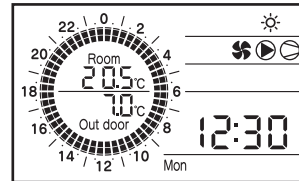

Cooling

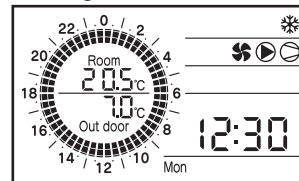

-Heating/Cooling time band active : Heating ↔ Cooling

Heating

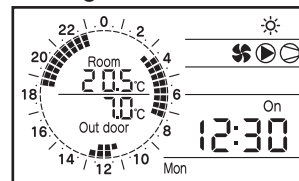

Cooling

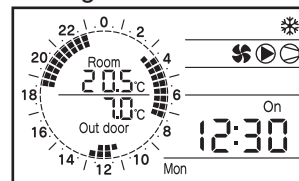

5. Operation and functions of the Remote controller

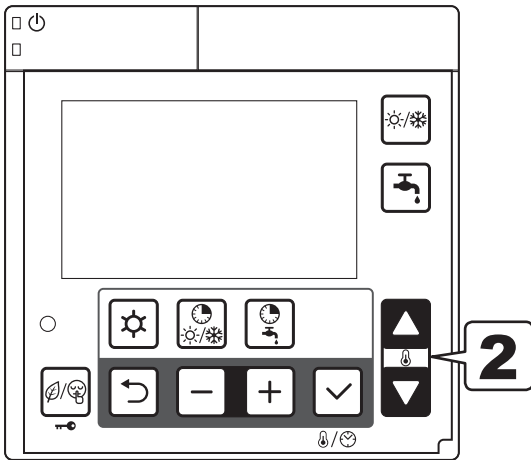

- 2** Press the Up or Down button to set the desired room set temperature. The temperature is adjusted by 0.5°C. Even when Clock/Set point display of the Remote controller has been set to Clock, pressing the Up or Down button changes it to Set point display; the set point can now be changed.

When the power is ON, Heating/Cooling and DHW will start up from the same condition as it is turned OFF the HP unit. Press the Mode switch to start the Heating or Cooling operation.

Note that when the current time has been set and the time band has been activated, operation proceeds according to the time band setting.

When time band is turned OFF from ON, the status of HP unit is stopped in Heating/Cooling.

Clock display

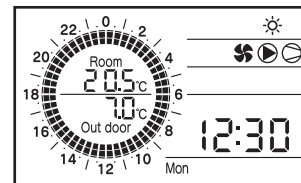

Room set point display

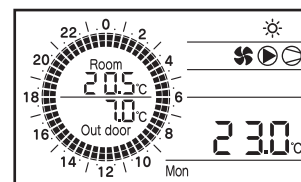

Change room set point

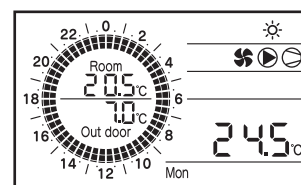

Note:

- 1) During time band operation, the room setting temperature displayed on Remote controller is the setting temperature of current operation in Comfort or Economy.
- 2) Even during time band operation, room setting temperature can be changed by Up or Down button of the Remote controller.
However, when the time band of Comfort/Economy is switched, the setting Room air temperature will be changed according to Comfort/Economy.
- 3) After time band operation is turned OFF and Heating/Cooling operation is started by Mode button Heating/Cooling, the unit will start the operation according to the room setting temperature for the previous operation mode (= time band operation).
(That means, it is not the previous room setting temperature by Mode buttons.)

5. Operation and functions of the Remote controller

5.4 Domestic Hot Water production

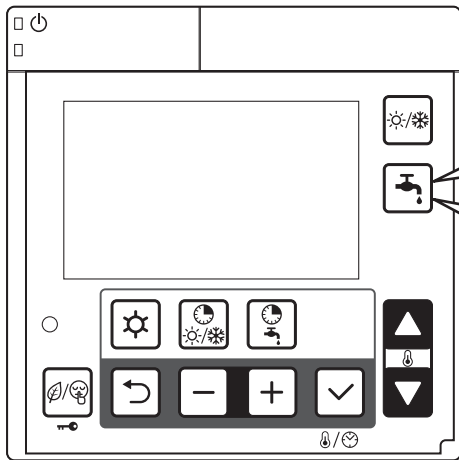

- 1 Press the DHW button to enable DHW production and change DHW mode OFF→Comfort→Economy

DHW OFF

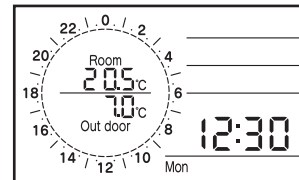

Comfort

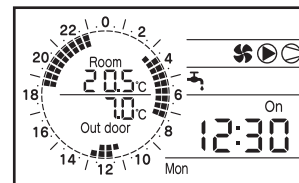

Economy

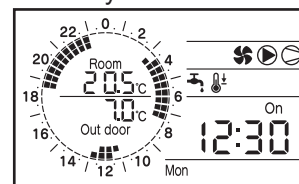

- 2 Press the DHW button for 3 seconds to enable DHW Force mode. In Force mode, hot water will be supplied to DHW tank until the DHW tank temperature reaches the Over boost set point. Force mode will be available until it is disabled by pressing the DHW button for 3 seconds.

Force

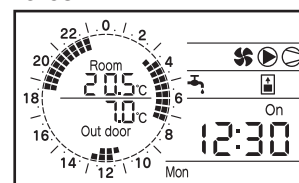

- 3 The set point temperature in each mode set by parameter.

Note: During DHW operation by DHW button, DHW set point can be switched because of DHW time band and Low tariff time band.

e.g.) DHW button (Comfort:50°C) → Time band (Economy:40°C)

DHW button (Economy:40°C) → Time band (Comfort:50°C), (Low tariff:50°C)

DHW button (Force:60°C) → Time band (Economy:40°C), (Comfort:50°C), (Low tariff:50°C)

5. Operation and functions of the Remote controller

5.5 Setting the time bands for Heating/Cooling

Activating or deactivating the time bands

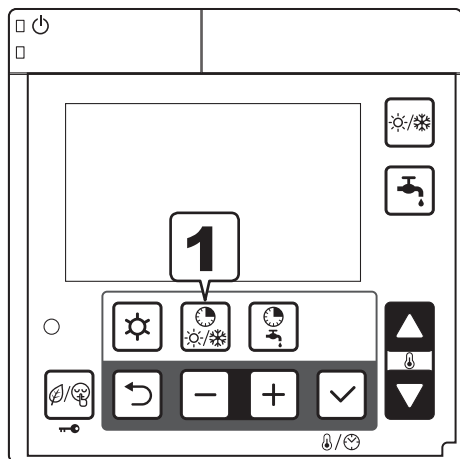

- 1 Push the Timer for Heating/Cooling button once to activate the time bands, once again to deactivate.

If the time bands is enabled, “On” icon is displayed.

If the time band is not set (at the plant shipment), the time band cannot be switched ON by the button.

Time band OFF

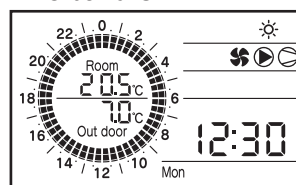

Time band ON

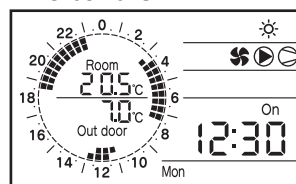

5. Operation and functions of the Remote controller

Settings related to time band operation

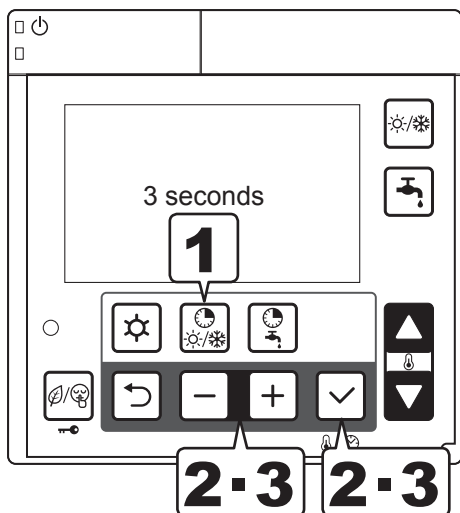

1 Press the Timer for Heating/Cooling button for 3 seconds to set the time bands for Heating/Cooling.

2 The number indicating the Zone blinks (Default: 1). Specify Zone1 or 2 using the - or + button and then press the Set button to save the setting.

Zone setting

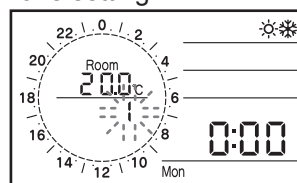

3 When the Zone has been saved, the day of week (Default: Mon) blinks. Specify the day of the week using the - or + button and then press the Set button to save the setting. The time bands can be programmed by selecting the days in present group or for each individual day.

Day setting

(Mon→Tue...Sat→Sun)

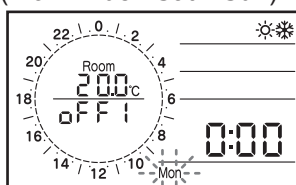

Day setting(7 days)

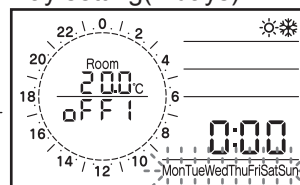

Day setting(Weekday)

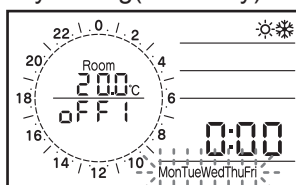

Day setting(Weekend)

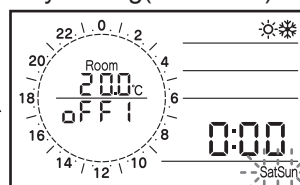

Note: Press the Return button to return to the previous item. Press the Timer for Heating/Cooling button for 3 seconds again to return to normal operation, or simply do nothing for approximately 2 minutes.

5. Operation and functions of the Remote controller

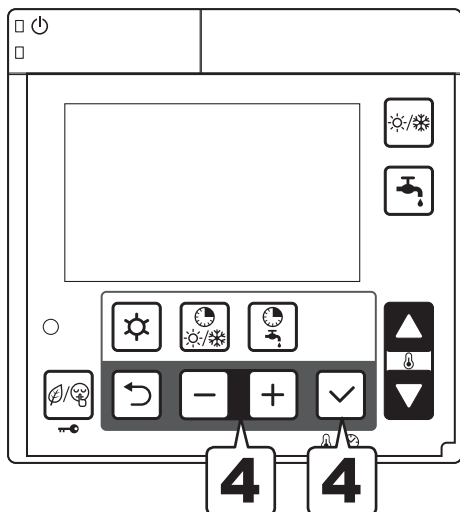

- 4** When the day of the week has been saved, the time band operation ON/OFF (Default: off) blinks. Specify either “on” or “off” using the - or + button and then press the Set button to save the setting.

ON/OFF setting

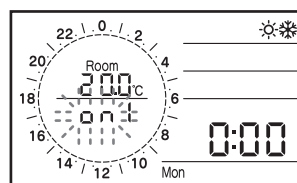
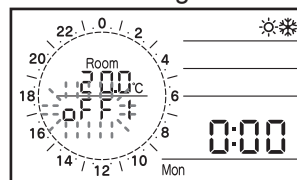

Note: The day of the week setting is prioritized as follows; Day of the week > Weekday, Weekend > 7 days.

Example: When 7 days and Wednesday are set to ON, Monday, Tuesday, Thursday, Friday, Saturday, and Sunday are common settings while Wednesday is a single setting.

5. Operation and functions of the Remote controller

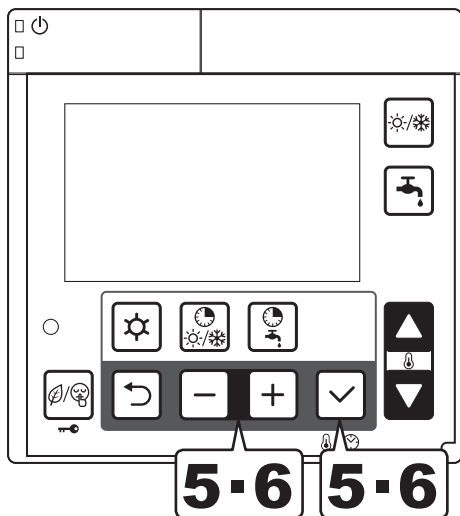

- 5** When the time band operation On/Off has been saved, Room set point for Heating/Cooling (Default: 20.0°C) blinks, Change the Comfort set point temperature using the - or + button, and press the Set button to save the setting.

Comfort set point setting

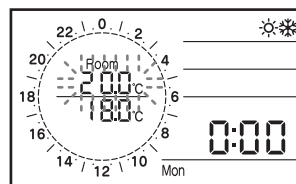

Then the Economy icon displays and set point temperature (Default: 18.0°C) blinks. And change the Economy set point temperature by using the - or + button, and press the Set button to save the setting.

(The temperature can be specified in increments of 0.5°C.)

Economy set point setting

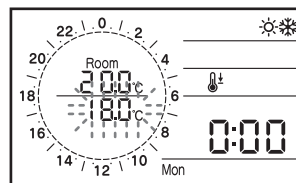

- 6** When the Room air temperature setting has been saved, the time displays “1 On”, and “0:00” blink; set the 1st ON time. When the - or + button is pressed, the time changes in 15 minute increments. Press the Set button to save the setting.

1st ON time setting

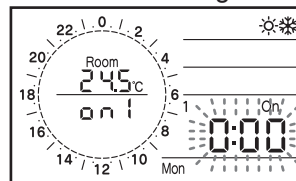

5. Operation and functions of the Remote controller

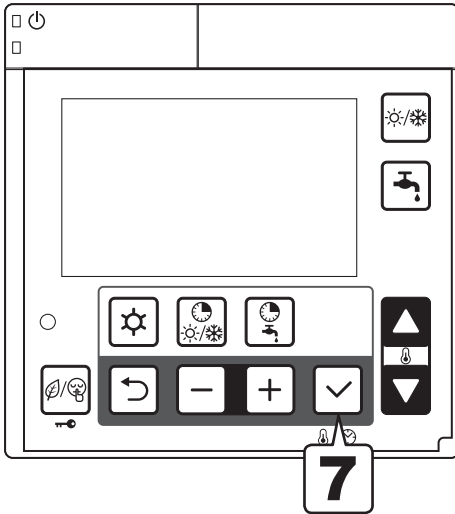

- 7** When the 1st ON time has been saved, “1 On” changes to “1 Off”. Set the 1st time band OFF time. After entering the “OFF time”, the gauge of the circle graph for ON time will be lighted, and then press the Set button to save the setting.

1st OFF time setting

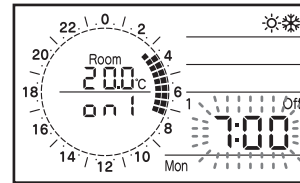

- 8** When the 1st OFF time has been saved, “1 Off” changes to “2 On”. Set the ON and OFF times of the 2nd and 3rd time bands according to the same procedures as in steps 6 to 8.

2nd ON time setting

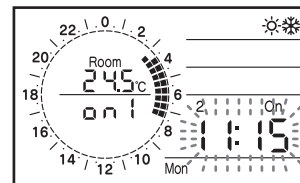

2nd OFF time setting

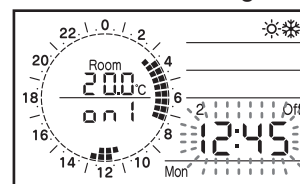

- 9** When the settings prior to the 3rd time band OFF time have been specified, the relevant day of the week setting is complete, and it returns to step 2. Then, set other zones and other day of the week.

Note1: When there is no setting for the 2nd and 3rd time bands, press Set button to proceed to 3rd OFF time. The same time will be applied for the 2nd and 3rd time bands. When the OFF time is the same as the previous ON time, HP unit will not be turned ON.

5. Operation and functions of the Remote controller

Note2: After 24:00, when the operation continues into the next day, set it to OFF at 24:00 on that day and then set it to ON at 0:00 in the next day.

The time bands for both Zone1 and Zone2 can be set using the Master Remote controller. The Slave Remote controller cannot be used for this setting.

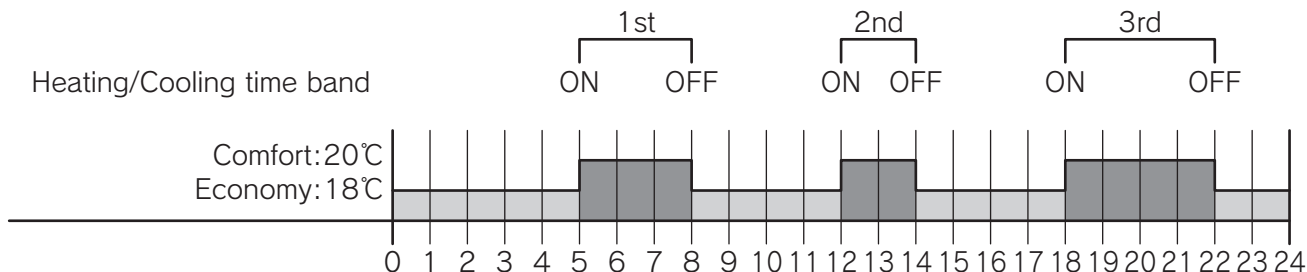

Parameter

Level	Parameter		Function description	Display & Input value				Remarks
	Group	Code		Default	min.	Max.	Unit	
U	01	16	Heating/Cooling time bands setting Zone1 0=disable 1=active (Comfort or Economy)	0	0	1	-	
U	01	17	Heating/Cooling time bands setting Zone2 0=disable 1=active (Comfort or Economy)	0	0	1	-	
U	01	18	DHW time band setting 0=disable 1=enable	0	0	1	-	
I	11	00	Time band is ON/OFF on Monday 0=OFF 1=ON	0	0	1	-	
I	11	01	Comfort room set temperature on Monday	20.0	12.0	40.0	0.5°C	
I	11	02	Economy room set temperature on Monday	18.0	12.0	40.0	0.5°C	
I	11	03	1st ON time on Monday	0:00	0:00	24:00	15min	
I	11	04	1st OFF time on Monday	0:00	0:00	24:00	15min	
I	11	05	2nd ON time on Monday	0:00	0:00	24:00	15min	
I	11	06	2nd OFF time on Monday	0:00	0:00	24:00	15min	
I	11	07	3rd ON time on Monday	0:00	0:00	24:00	15min	
I	11	08	3rd OFF time on Monday	0:00	0:00	24:00	15min	
I	11	10	Time band is ON/OFF on Tuesday 0=OFF 1=ON	0	0	1	-	
I	11	11	Comfort room set temperature on Tuesday	20.0	12.0	40.0	0.5°C	
I	11	12	Economy room set temperature on Tuesday	18.0	12.0	40.0	0.5°C	
I	11	13	1st ON time on Tuesday	0:00	0:00	24:00	15min	
I	11	14	1st OFF time on Tuesday	0:00	0:00	24:00	15min	
I	11	15	2nd ON time on Tuesday	0:00	0:00	24:00	15min	
I	11	16	2nd OFF time on Tuesday	0:00	0:00	24:00	15min	
I	11	17	3rd ON time on Tuesday	0:00	0:00	24:00	15min	
I	11	18	3rd OFF time on Tuesday	0:00	0:00	24:00	15min	

Certain parameter lists are not included here; only a general description is presented, as follows.

For details, refer to the Parameter list at the end of this manual.

Zone1=Group11

Monday=1100~1108, Tuesday=1110~1118, Wednesday=1120~1128, Thursday=1130~1138,
Friday=1140~1148, Saturday=1150~1158, Sunday=1160~1168, Weekday (5days)=1170~1178,
Weekend (2days)=1180~1188, Every day (7days)=1190~1198

Zone2=Group12

Monday=1200~1208, Tuesday=1210~1218, Wednesday=1220~1228, Thursday=1230~1238,
Friday=1240~1248, Saturday=1250~1258, Sunday=1260~1268, Weekday (5days)=1270~1278,
Weekend (2days)=1280~1288, Every day (7days)=1290~1298

5. Operation and functions of the Remote controller

5.6 Setting the time bands for DHW, Low tariff and Night mode

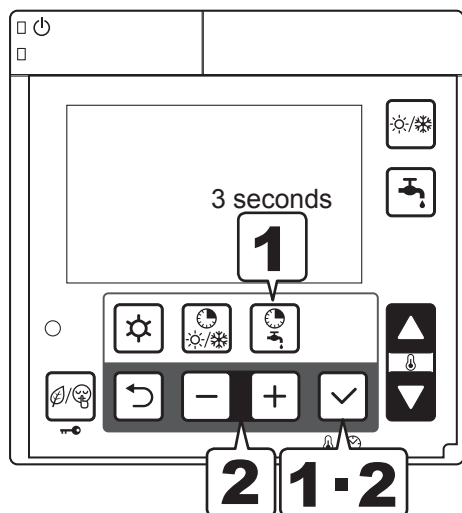

1 Press the “Timer for DHW” button for 3 seconds to set the time bands for DHW.

2 The icon of DHW Comfort/Low tariff/Night mode will blink, select the mode by pressing - or + button, and press Set button to confirm the setting mode.

Select the mode DHW

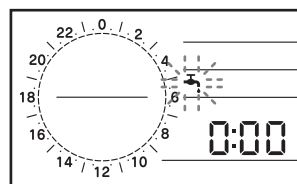

Select the mode Low tariff

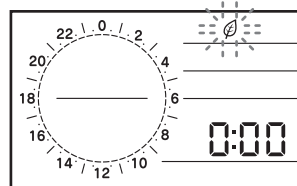

Select the mode Night

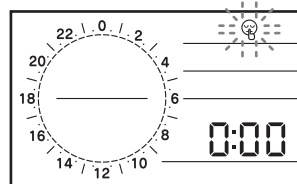

Note: Press the Return button to return to the previous item. Press the Timer for DHW button for 3 seconds again to return to normal operation, or simply do nothing for approximately 2 minutes.

5. Operation and functions of the Remote controller

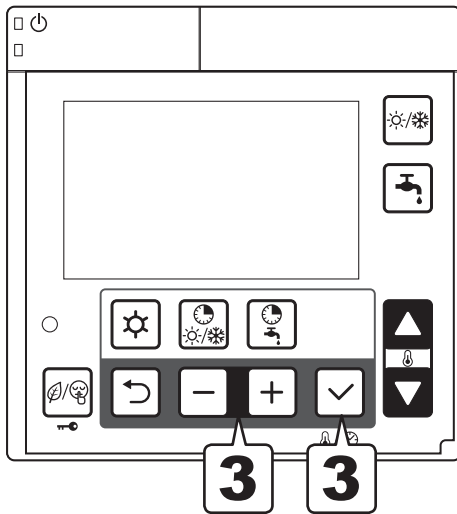

3 When the DHW Comfort icon displays and DHW Comfort set point (Default: 50°C) blinks, change the DHW Comfort set point using the - or + button, and press Set button to save the setting.

Then the DHW Economy icon displays and DHW Economy set point (Default: 40°C) blinks, change the DHW Economy set point using the - or + button, and press Set button to save the setting. (The temperature can be specified in increments of 0.5°C.)

For the Low tariff and Night mode settings, there are no temperature settings, then proceed to the next item.

DHW Comfort set point setting

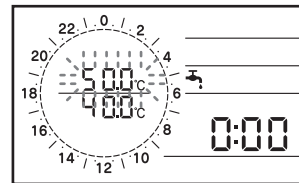

DHW Economy set point setting

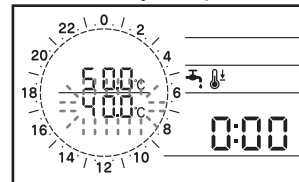

5. Operation and functions of the Remote controller

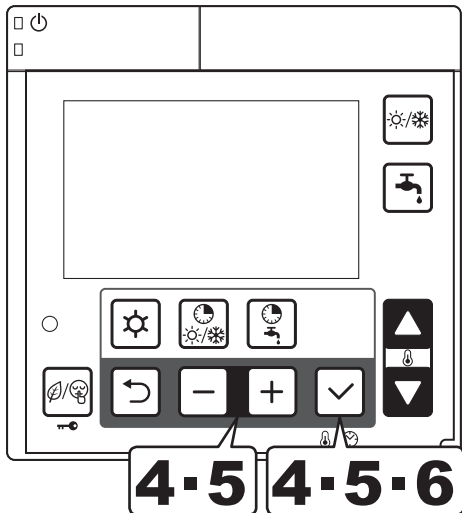

- 4** When DHW Comfort/Economy set point has been saved (in Low tariff or Night mode, when the mode selection has been saved), “1 On” displays and “0:00” blinks; set the 1st ON time. When the - or + button is pressed, the time changes in 15 minute increments. Press the Set button to save the setting.

1st ON time setting

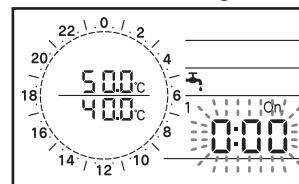

- 5** When the 1st ON time has been saved, “1 On” changes to “1 Off”. Set the 1st time band OFF time. After entering the “Off time”, the gauge of the circle graph for ON time will be lit, and then press the Set button to save the setting.

1st OFF time setting

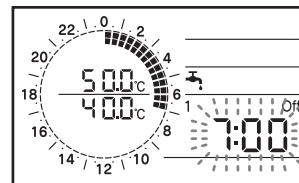

- 6** When the 1st OFF time has been saved, “1 Off” changes to “2 On”. Set the ON and OFF times of the 2nd and 3rd time bands according to the same procedures as in steps 4 to 6.

2nd ON time setting

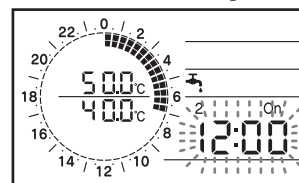

2nd OFF time setting

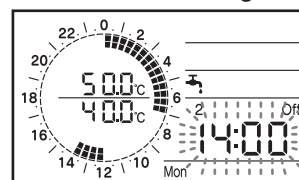

5. Operation and functions of the Remote controller

- 7** When the setting of the 3rd time band OFF time has been specified, the relevant mode setting is complete. Return to step **2** for mode selection.

- 8** Specify the setting for each mode according to the same procedures as in steps **3** to **8**.
The schedule will be the same for every day.

Note1: When there is no setting for the 2nd and 3rd time bands, press Set button to proceed to 3rd OFF time. The same time will be applied for the 2nd and 3rd time bands. When the OFF time is same as the previous ON time, HP unit will not be turned ON.

Note2: After 24:00, when the operation continues into the next day, set it to OFF at 24:00 on that day and then set it to ON at 0:00 in the next day.

The Time bands can be set using the Master Remote controller. The Slave Remote controller cannot be used for this setting.

5. Operation and functions of the Remote controller

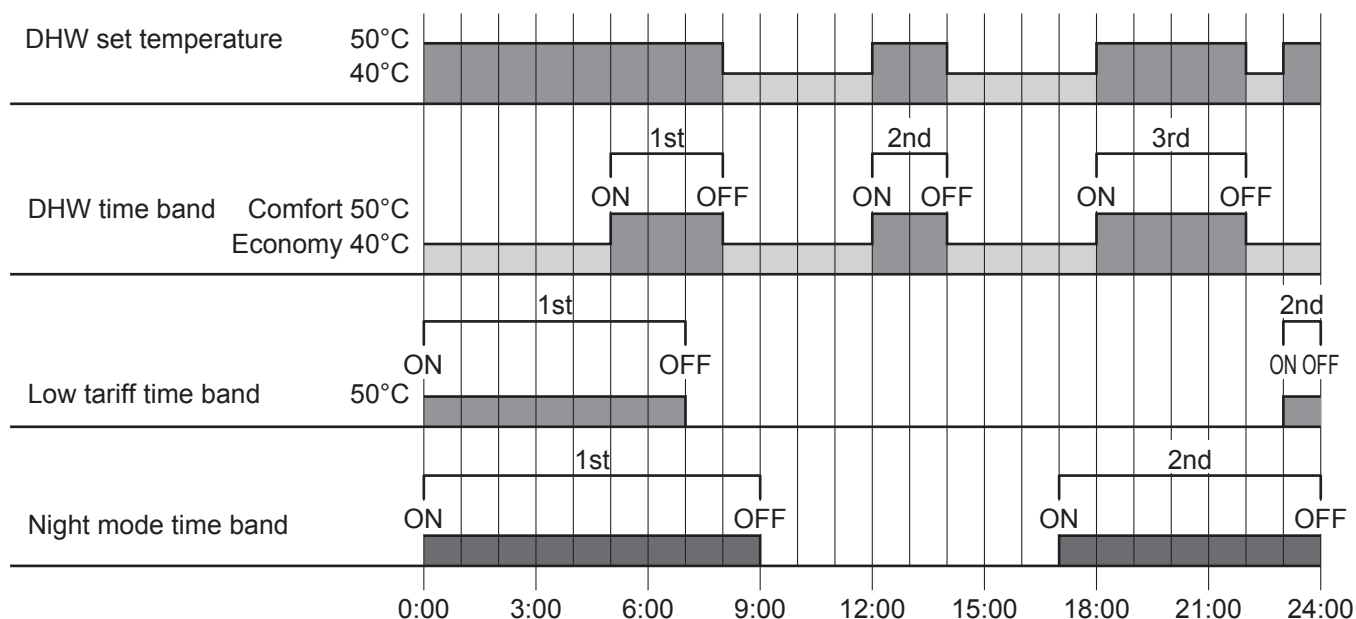

Parameter

Level	Parameter		Function description	Display & Input value				Remarks
	Group	Code		Default	min.	Max.	Unit	
U	01	18	DHW time band setting 0=disable 1=enable	0	0	1	-	
U	01	19	Low tariff and Night mode setting 0=disable 1=Low tariff 2=Night mode 3=Low tariff and Night mode	0	0	3	-	Set by Remote controller or remote contact.
I	31	11	DHW Comfort set temperature	50.0	40.0	75.0	0.5°C	
I	31	12	DHW Economy set temperature	40.0	30.0	65.0	0.5°C	
I	13	01	DHW Comfort 1st ON time	0:00	0:00	24:00	15min	
I	13	02	DHW Comfort 1st OFF time	0:00	0:00	24:00	15min	
I	13	03	DHW Comfort 2nd ON time	0:00	0:00	24:00	15min	
I	13	04	DHW Comfort 2nd OFF time	0:00	0:00	24:00	15min	
I	13	05	DHW Comfort 3rd ON time	0:00	0:00	24:00	15min	
I	13	06	DHW Comfort 3rd OFF time	0:00	0:00	24:00	15min	
I	13	11	Low tariff 1st ON time	0:00	0:00	24:00	15min	
I	13	12	Low tariff 1st OFF time	0:00	0:00	24:00	15min	
I	13	13	Low tariff 2nd ON time	0:00	0:00	24:00	15min	
I	13	14	Low tariff 2nd OFF time	0:00	0:00	24:00	15min	
I	13	15	Low tariff 3rd ON time	0:00	0:00	24:00	15min	
I	13	16	Low tariff 3rd OFF time	0:00	0:00	24:00	15min	
I	13	21	Night mode 1st ON time	0:00	0:00	24:00	15min	
I	13	22	Night mode 1st OFF time	0:00	0:00	24:00	15min	
I	13	23	Night mode 2nd ON time	0:00	0:00	24:00	15min	
I	13	24	Night mode 2nd OFF time	0:00	0:00	24:00	15min	
I	13	25	Night mode 3rd ON time	0:00	0:00	24:00	15min	
I	13	26	Night mode 3rd OFF time	0:00	0:00	24:00	15min	

5. Operation and functions of the Remote controller

5.7 Procedure for accessing the Parameter setting menu

USER level

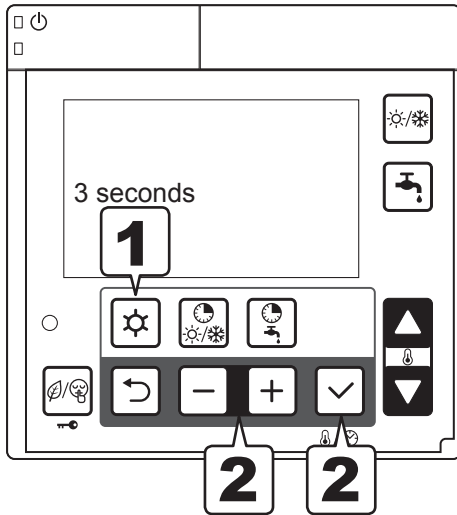

1 Press the Menu buttons for 3 seconds.

2 Parameter number “0000” and parameter value “- - - -” will be displayed in the display. Among 4 digits of parameter numbers, 2 digits of them which indicates group or code numbers will be flashed. Press - or + button to switch the flashing 2 digits from left 2 showing group numbers to right 2 showing code numbers.

Select parameter group numbers



Select parameter code numbers



Note1: The Parameter setting menu can be set using the Master Remote controller. The Slave Remote controller cannot be used for this.

5. Operation and functions of the Remote controller

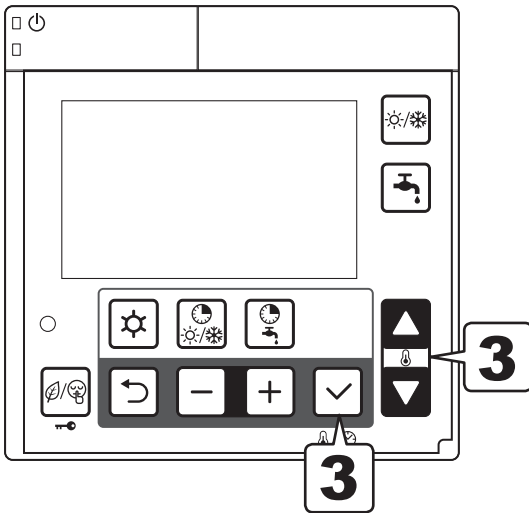

- 3** Select the group and code numbers by pressing the Up or Down button, and press Set button to display the parameter value in the display.

If invalid parameters (the value which is not on the parameter list or not accessible due to INSTALLER level) are entered and Set button is pressed, the indication “- - - -” is displayed.

Press the Return button to return to the previous item.

Select parameter number

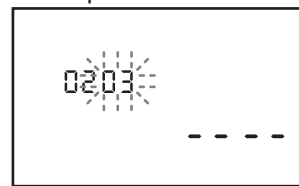

Display parameter value

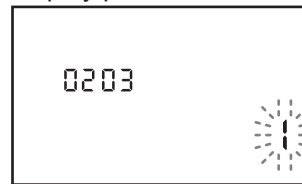

Change parameter value



Saved parameter value

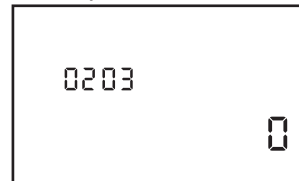

5. Operation and functions of the Remote controller

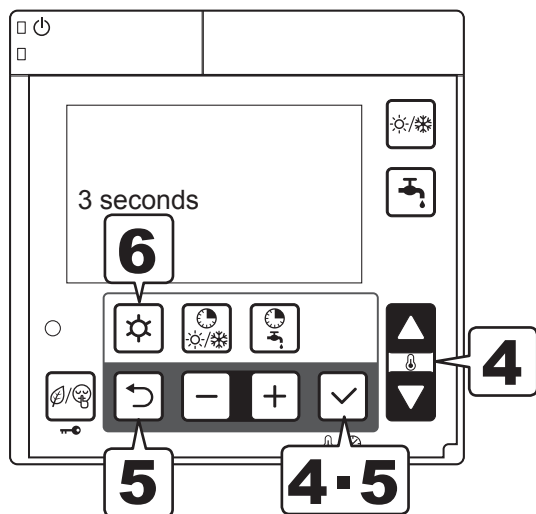

- 4** When it is possible to change the parameter setting items, the displayed current parameter value will blink.

Change the number in the same manner as in step 3. When the Set button is pressed, the number is saved and updated accordingly. The number stops blinking and remains on continuously.

For unchangeable items (read-only items), the number displayed remains on, then pressing the Set button does not affect the display.

- 5** Press the Return or Set button, the parameter code numbers blinks.

To access other parameter code numbers without an interval, repeat the same steps.

Return to select parameter code numbers



- 6** To return to normal operation, press and hold the Menu button for 3 seconds, or simply do nothing for approximately 10 minutes.

5. Operation and functions of the Remote controller

INSTALLER level

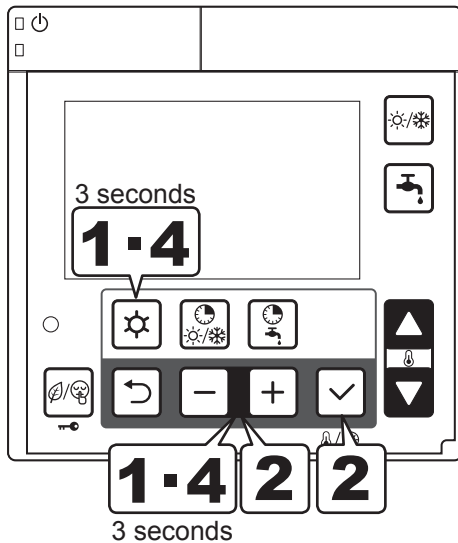

- 1** Press the Menu, -, and + buttons simultaneously for 3 seconds.
- 2** “InSt” and parameter number “0000” and parameter value “- - - -” will be displayed in the display.
Among 4 digits of parameter numbers, 2 digits of them which indicates group or code numbers will be flashed.
Press “- or + button” to switch the flashing 2 digits from left 2 showing group numbers to right 2 showing code numbers.

Select parameter group numbers



Select parameter code numbers



- 3** In INSTALLER level, more parameters than USER level can be accessed.

The procedures of setting parameters are same as USER level.

If invalid parameters (the value which is not on the parameter list or not accessible level) are entered and Set button is pressed, the indication “- - - -” is displayed. Press the Return button to return to the previous item.

- 4** To return to normal operation, press and hold the Menu, - and + button for 3 seconds, or simply do nothing for approximately 10 minutes.

Note1: The Parameter setting menu can be set using the Master Remote controller. The Slave Remote controller cannot be used for this.

6. Electrical connections

6.1 PCB (Terminal)

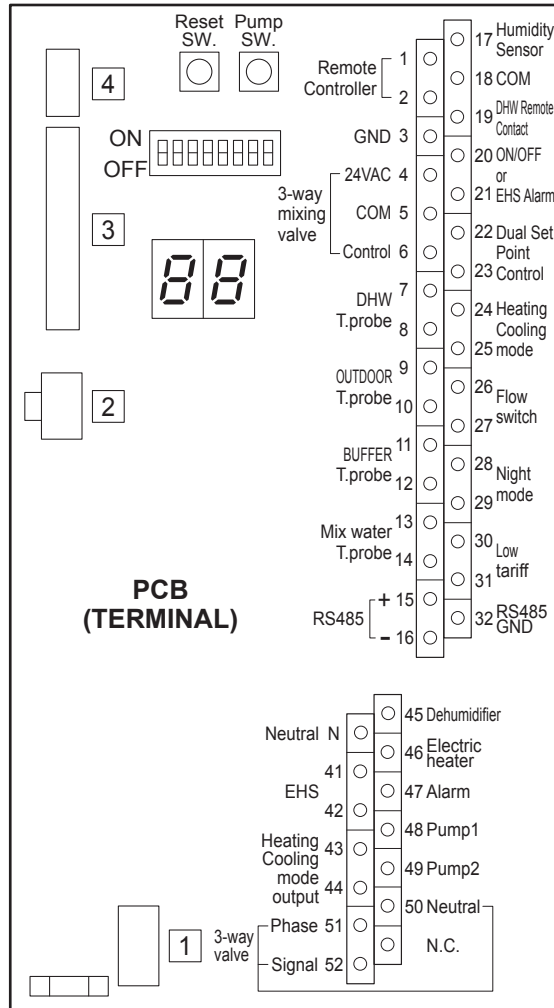

6. Electrical connections

6.2 PCB(Terminal) Input/Output

Serial connections

Terminal	Function	Analogue Input	Remarks
1 - 2 - 3	Remote Controller	1=S1, 2=S2, 3=GND	Wire length is maximum 100m with 1mm ² shielded cables.
15 - 16 - 32	RS485 Mod Bus	15=+, 16=-, 32=GND	

Analogue/Digital INPUTS

Terminal	Function	Analogue Input	Digital Input
9 - 10	Outdoor air temperature probe (additional probe than the probe positioned on the HP unit)	NTC Resistance R25=10kΩ +/-1% B25/85=3970K +/-1%	Voltage free contact 12V10mA
7 - 8	DHW tank temperature probe	NTC	
11 - 12	Buffer tank temperature probe	Resistance R25=10kΩ +/-1% B25/85=3435K +/-1%	
13 - 14	Mix Water temperature probe		
17 - 18	Humidity Sensor	0-10V DC	
19 - 18	DHW remote contact		
20 - 21	Configurable input: -ON/OFF remote contact -EHS Alarm		
22 - 23	Dual Set Point Control		
24 - 25	Heating/Cooling mode remote contact		
26 - 27	Flow switch		
28 - 29	Configurable input: -Night mode -SG Ready 1		
30 - 31	Configurable input: -Low tariff -SG Ready 2		

Note: The maximum length of probe cables is 100m for 1mm² cables, and 30m for 0.5mm² cables.

Analogue/Digital OUTPUTS

Terminal	Function	Analogue Output	Digital Output
4 - 5 - 6	3way mixing valve	6=0-10V DC (control)	4-5 =24V AC
N	Neutral		1ph 230V, 1A Neutral
41 - 42	EHS (External heat source for space heating)		1ph 230V, 1A (in case of coil relay 40mA)
43 - 44	Heating/Cooling mode output		
45	Dehumidifier		
46	Electric heater for DHW or Backup heater		
47	Alarm (Configurable output) - Alarm - Ambient temperature reached		
48	Pump1 (1st Additional water pump)		
49	Pump2 (2nd Additional water pump)		
50 - 51 - 52	DHW 3way valve		1ph 230V, 1A 50=Neutral, 51=Phase, 52=Signal

Note: The maximum length of probe cables is 100m for 1mm² cables, and 30m for 0.5mm² cables.

6. Electrical connections

6.3 Parameters Input/Output

Level	Parameter		Function description	Display & Input value				Remarks	
	Group	Code		Default	min.	Max.	Unit		
I	51	01	Terminal 1-2-3 : Remote Controller 1= <u>enable</u>	1	1	1	-		
I	51	04	Terminal 4-5-6 : 3way mixing valve 0= <u>disable</u> 1= <u>enable</u>	0	0	1	-		
I	51	07	Terminal 7-8 : DHW tank temperature probe 0= <u>disable</u> 1= <u>enable</u>	0	0	1	-		
I	51	09	Terminal 9-10 : Outdoor air temperature probe (additional) 0= <u>disable</u> 1= <u>enable</u>	0	0	1	-		
I	51	11	Terminal 11-12 : Buffer tank temperature probe 0= <u>disable</u> 1= <u>enable</u>	0	0	1	-		To be set to the following combinations Par5111=0 →Par4200=0or2 Par5111=1 →Par4200=0or1
I	51	13	Terminal 13-14 : Mix Water temperature probe 0= <u>disable</u> 1= <u>enable</u>	0	0	1	-		
I	51	15	Terminal 15-16-32 : RS485 Mod Bus 0= <u>disable</u> 1= <u>enable</u>	1	0	1	-		
I	51	17	Terminal 17-18 : Humidity sensor 0= <u>disable</u> 1= <u>enable</u>	0	0	1	-		
I	51	19	Terminal 19-18 : DHW remote contact 0= <u>disable (Remote controller only)</u> 1= <u>enable</u>	0	0	1	-		
I	51	20	Terminal 20-21 : ON/OFF remote contact or EHS Alarm input 0= <u>disable</u> 1=ON/OFF remote contact 2=EHS Alarm input	0	0	2	-		ON/OFF by Remote controller 0=enable 1=ON/disable OFF/enable 2=enable
I	51	22	Terminal 22-23 : Dual set point control 0= <u>disable</u> 1= <u>enable</u>	1	0	1	-		
I	51	24	Terminal 24-25 : Heating/Cooling mode remote contact 0= <u>disable (Remote controller only)</u> 1=Cooling is CLOSE contact, Heating is OPEN contact. 2=Cooling is OPEN contact, Heating is CLOSE contact	0	0	2	-		
I	51	26	Terminal 26-27 : Flow switch 0= <u>disable</u> 1= <u>enable</u>	1	0	1	-		
I	51	28	Terminal 28-29 : Night mode 0= <u>disable</u> 1= <u>enable</u>	0	0	1	-		
I	51	30	Terminal 30-31 : Low tariff 0= <u>disable</u> 1= <u>enable</u>	0	0	1	-	Par5128 and Par5130 are synchronized in same value	
I	51	41	Terminal 41-42 : EHS (External heat source for space heating) 0= <u>disable</u> 1= <u>enable</u>	0	0	1	-		
I	51	43	Terminal 43-44 : Heating/Cooling mode output 0= <u>disable</u> 1=Indication of Cooling mode (CLOSE=Cooling) 2=indication of Heating mode (CLOSE=Heating)	0	0	2	-		

6. Electrical connections

Level	Parameter		Function description	Display & Input value				Remarks
	Group	Code		Default	min.	Max.	Unit	
I	51	45	Terminal 45 : Dehumidifier <u>0=disable</u> 1=enable	0	0	1	-	
I	51	46	Terminal 46 : DHW Electric heater or Backup heater <u>0=DHW Electric heater</u> 1=Backup heater	0	0	1	-	
I	51	47	Terminal 47 : Alarm (Configurable output) <u>0=disable</u> 1=Alarm 2=Ambient temperature reached	0	0	2	-	
I	51	48	Terminal 48 : Pump1 <u>0=disable</u> 1=1st Additional water pump1 for Zone1	0	0	1	-	
I	51	49	Terminal 49 : Pump2 <u>0=disable</u> 1=2nd Additional water pump2 for Zone2	0	0	1	-	
I	51	50	Terminal 50-51-52 : DHW 3way valve <u>1=enable</u>	1	1	1	-	

7. Unit Management

7.1 Operating modes

The Heating and Cooling operating modes can be set, either from the Remote controller or remote contact.

7.1.1 Select mode from user interface

The modes of function (Heating/Cooling) are selected pushing the dedicated Mode button.

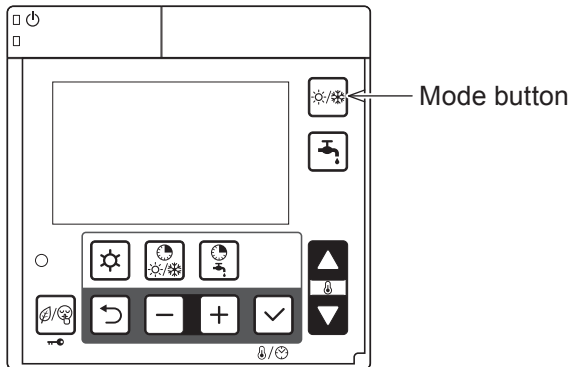

7.1.2 Select mode by remote contact

If remote Heating/Cooling changeover is enabled (dedicated parameter), the operating mode cannot be changed on the Remote controller.

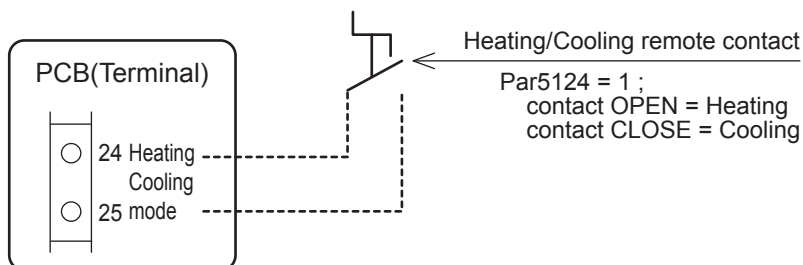

Parameters

Level	Parameter		Function description	Display & Input value				Remarks
	Group	Code		Default	min.	Max.	Unit	
I	51	24	Terminal 24-25 : Heating/Cooling mode remote contact 0=disable (Remote controller only) 1=Cooling is CLOSE contact, Heating is OPEN contact 2=Cooling is OPEN contact, Heating is CLOSE contact	0	0	2	-	

7. Unit Management

7.2 Water temperature set point

The water temperature set point can be selected with “traditional” mode, i.e. based on a fixed set point programmed by the user, or in “advanced” mode, with a variable set point calculated automatically using climatic curves, both in Heating and Cooling mode, as described below. The choice between Fixed set point or variable set point will be defined by dedicated parameter.

7.2.1 Fixed set point

The heat pump will operate based on the fixed outgoing water set-point defined by parameters. The installer will set the value for Heating and Cooling, defined per each Zone by dedicated parameter.

Parameters

Level	Parameter		Function description	Display & Input value				Remarks
	Group	Code		Default	min.	Max.	Unit	
I	21	00	Heating Zone1, enable Outgoing water set point 0=Fixed set point 1=Climatic curve	0	0	1	-	
I	21	01	Heating Zone1, Fixed Outgoing water set point in Heating	45.0	23.0	75.0	0.5°C	
I	21	10	Heating Zone2, enable Outgoing water set point 0=Fixed set point 1=Climatic curve enabled	0	0	1	-	
I	21	11	Heating Zone 2, Fixed Outgoing water set point in Heating	45.0	23.0	75.0	0.5°C	
I	21	20	Cooling Zone 1, enable Outgoing water set point 0=Fixed set point 1=Climatic curve enabled	0	0	1	-	
I	21	21	Cooling Zone 1, Fixed Outgoing water set point in Cooling	7.0	7.0	23.0	0.5°C	
I	21	30	Cooling Zone2, enable Outgoing water set point 0=Fixed set point 1=Climatic curve enabled	0	0	1	-	
I	21	31	Cooling Zone2, Fixed Outgoing water set point in Cooling	7.0	7.0	23.0	0.5°C	
I	21	41	Hysteresis of water set point in Heating and DHW	8.0	4.0	10.0	0.5°C	
I	21	42	Hysteresis of water set point in Cooling	8.0	4.0	10.0	0.5°C	

7. Unit Management

7.2.2 Climatic curve

The Outgoing water temperature set point in Heating or Cooling mode is calculated based on the Outdoor air temperature trend according to selectable curves.

7.2.2.1 Heating Climatic curves

The logic regulating the temperature of the requested outlet water to the HP unit, in normal winter Heating or summer Cooling operation, is based on the Climatic curves.

The basic logic is to modulate the temperature of the requested outlet water, depending on the Outdoor air temperature.

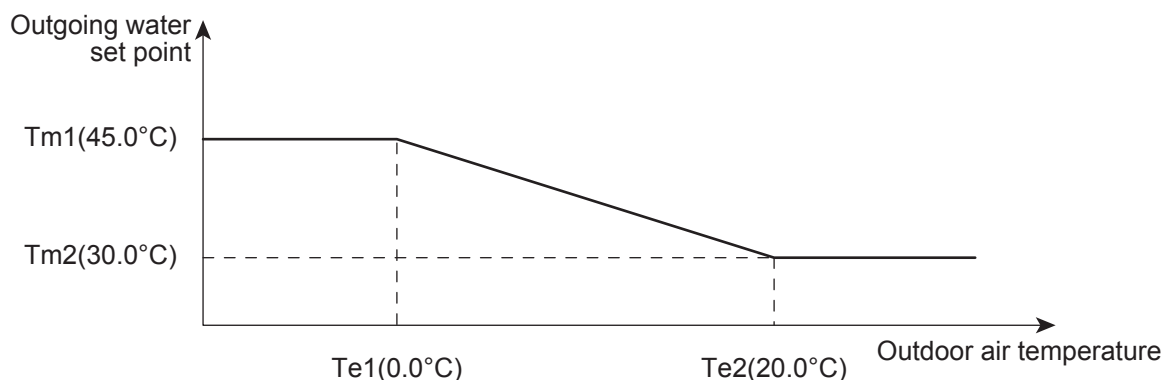

Parameters

Level	Parameter		Function description	Display & Input value				Remarks
	Group	Code		Default	min.	Max.	Unit	
I	21	00	Heating Zone1, enable Outgoing water set point 0=Fixed set point 1=Climatic curve	0	0	1	-	
I	21	02	Max. Outgoing water temperature in Heating mode (Tm1) Zone1	45.0	23.0	75.0	0.5°C	
I	21	03	Min. Outgoing water temperature in Heating mode (Tm2) Zone1	30.0	23.0	75.0	0.5°C	
I	21	04	Min. Outdoor air temperature corresponding to max. Outgoing water temperature (Te1) Zone1	0.0	-20.0	50.0	0.5°C	
I	21	05	Max. Outdoor air temperature corresponding to max. Outgoing water temperature (Te2) Zone1	20.0	0.0	40.0	0.5°C	
I	21	10	Heating Zone2, enable outgoing water set point 0=Fixed set point 1=Climatic curve enabled	0	0	1	-	
I	21	12	Max. Outgoing water temperature in Heating mode (Tm1) Zone2	45.0	23.0	75.0	0.5°C	
I	21	13	Min. Outgoing water temperature in Heating mode (Tm2) Zone2	30.0	23.0	75.0	0.5°C	
I	21	14	Min. Outdoor air temperature corresponding to max. Outgoing water temperature (Te1) Zone2	0.0	-20.0	50.0	0.5°C	
I	21	15	Max. Outdoor air temperature corresponding to max. Outgoing water temperature (Te2) Zone2	20.0	0.0	40.0	0.5°C	
I	21	41	Hysteresis of water set point in Heating and DHW	8.0	4.0	10.0	0.5°C	

7. Unit Management

7.2.2.2 Cooling Climatic curves

The compensation curves in Cooling mode can be modified to allow correct HP unit operation depending on the Cooling system used (radiant panels, fan coils).

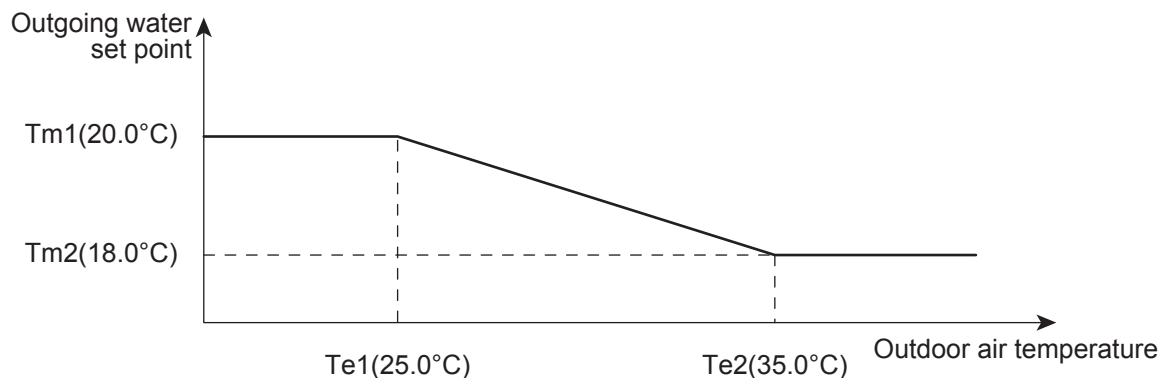

Parameters

Level	Parameter		Function description	Display & Input value				Remarks
	Group	Code		Default	min.	Max.	Unit	
I	21	20	Cooling Zone1, enable Outgoing water set point 0=Fixed set point 1=Climatic curve enabled	0	0	1	-	
I	21	22	Max. Outgoing water temperature in Cooling mode (Tm1) Zone1	20.0	7.0	23.0	0.5°C	
I	21	23	Min. Outgoing water temperature in Cooling mode (Tm2) Zone1	18.0	7.0	23.0	0.5°C	
I	21	24	Min. Outdoor air temperature corresponding to max. Outgoing water temperature (Te1) Zone1	25.0	0.0	50.0	0.5°C	
I	21	25	Max. Outdoor air temperature corresponding to max. Outgoing water temperature (Te2) Zone1	35.0	0.0	50.0	0.5°C	
I	21	30	Cooling Zone2, enable outgoing water set point 0=Fixed set point 1=Climatic curve enabled	0	0	1	-	
I	21	32	Max. Outgoing water temperature in Cooling mode (Tm1) Zone2	20.0	7.0	23.0	0.5°C	
I	21	33	Min. Outgoing water temperature in Cooling mode (Tm2) Zone2	18.0	7.0	23.0	0.5°C	
I	21	34	Min. Outdoor air temperature corresponding to max. Outgoing water temperature (Te1) Zone2	25.0	0.0	50.0	0.5°C	
I	21	35	Max. Outdoor air temperature corresponding to max. Outgoing water temperature (Te2) Zone2	35.0	0.0	50.0	0.5°C	
I	21	42	Hysteresis of water set point in Cooling	8.0	4.0	10.0	0.5°C	

7. Unit Management

7.2.3 Additional Outdoor air temperature probe for Climatic curves

If the positioning of the HP unit is non-representative to measure the Outdoor air temperature for a correct calculation of the water set point by Climatic curve, an additional temperature probe can be provided.

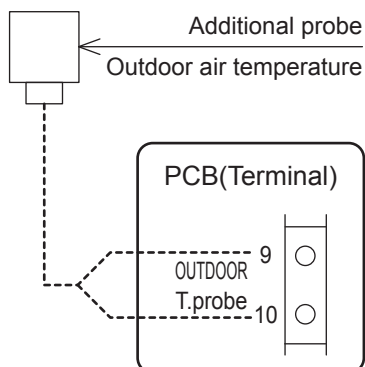

The maximum length of probe cables is 100m for 1mm² cables, and 30m for 0.5mm² cables.

Distance	Cable(mm ²)
~30m	MIN 0.5
30~100m	MIN 1.0

Additional Outdoor air temperature probe must be installed:

- outside of the home
- not in direct sunlight, away from flue gas discharges, air outlets, or doors and windows
- on a perimeter wall facing north/north-west
- at a minimum height of 2.5m above the ground or at most half way up the house.

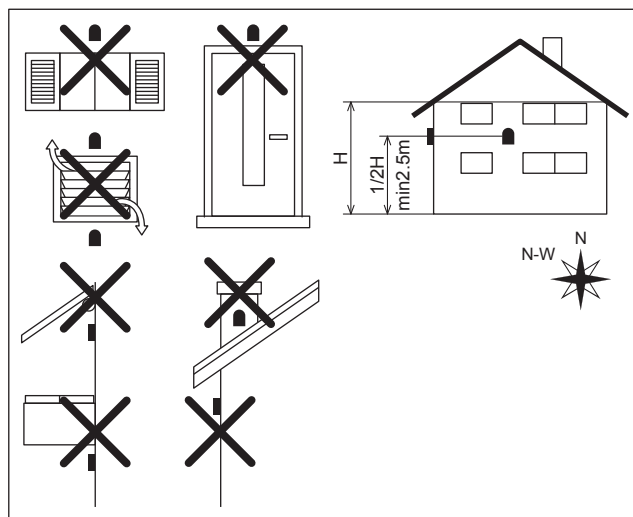

Parameters

Level	Parameter		Function description	Display & Input value				Remarks
	Group	Code		Default	min.	Max.	Unit	
I	51	09	Terminal 9-10 : Outdoor air temperature probe (additional) 0=disable 1=enable	0	0	1	-	

With additional Outdoor air temperature probe and Par5109=1 (enable), the detected temperature is applicable to the followings;

- 7.2.2 Climatic curve
- 8.2.3 Heat pump + DHW heater
- 8.3.1.2 Depends on Outdoor air temperature
- 8.3.2 Backup heater in supplementary mode
- 8.4.1 EHS in Replacement mode
- 8.4.2 EHS in Supplementary mode

7. Unit Management

7.2.4 Buffer tank temperature probe

If using the Buffer tank temperature probe and it is enabled, the compressor and water pump turns ON/OFF based on water temperature measured by the Buffer tank temperature probe. The functions of “Backup heater” and the “External heat source (EHS)” will be referred to the Buffer tank temperature probe, if enabled by dedicated parameter.

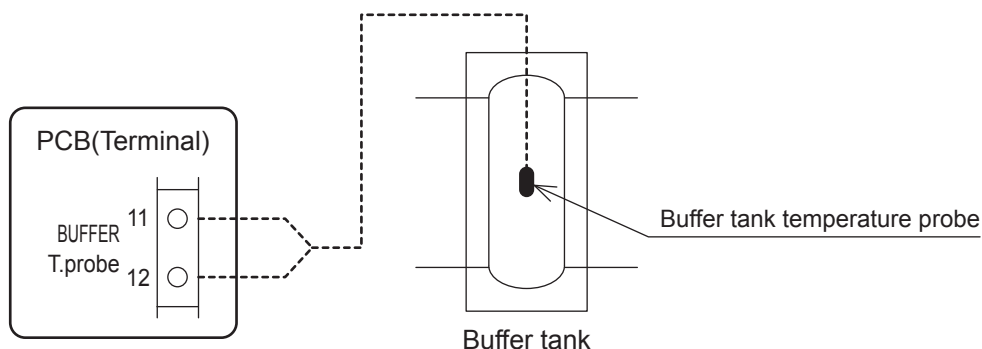

Parameters

Level	Parameter		Function description	Display & Input value				Remarks
	Group	Code		Default	min.	Max.	Unit	
I	51	11	Terminal 11-12 : Buffer tank temperature probe 0=disable 1=enable	0	0	1	-	To be set to the following combinations Par5111=0 →Par4200=0 or 2 Par5111=1 →Par4200=0 or 1 or 2
I	42	00	Type of configuration of Main water pump 0=always ON 1=ON/OFF based on Buffer tank temperature 2=ON/OFF based on Sniffing cycles	0	0	2	-	
I	21	41	Hysteresis of water set point in Heating and DHW	8.0	4.0	10.0	0.5°C	
I	21	42	Hysteresis of water set point in Cooling	8.0	4.0	10.0	0.5°C	
I	21	61	Buffer tank set point for Heating	45.0	23.0	75.0	0.5°C	
I	21	62	Buffer tank set point for Cooling	7.0	7.0	23.0	0.5°C	

Par4200 (Main water pump operation) shall be the following combination corresponding to Par5111, Buffer tank temperature probe;

Par5111=0 (Buffer tank temperature probe disable) →Par4200=0 or 2

Par5111=1 (Buffer tank temperature probe enable) →Par4200=0 or 1 or 2

Par2161 and Par2162 (Buffer tank set point) shall be set higher in Heating or lower in Cooling than set points of Zone1 and Zone2.

7. Unit Management

7.2.5 HP unit control

The HP unit control based on:

- 1) Outgoing water temperature (measured by Outgoing water sensor on HP unit)
- 2) Outgoing water temperature and Room air temperature (measured by sensor on board of the Remote controller)
- 3) Buffer tank temperature (measured by Buffer tank sensor)
- 4) Buffer tank temperature and Room air temperature
- 5) DHW tank temperature (measured by DHW tank sensor)

During Heating/Cooling operations, Par4100 shall be set to select the ON/OFF of the HP unit based on either the water temperature and the Room air temperature or only water temperature settings.

The operation by water temperature can be "Outgoing water temp." or "Buffer tank temp.". If Par5111 is set to "enable" for Buffer tank temp. sensor, the operation shall be based on Buffer tank temp..

In case of the operation by Room air temperature and reaching the set point,

- based on Outgoing water temp: HP unit shall be ON/OFF
- based on Buffer tank temp: the additional water pump in the applicable zone shall be ON/OFF

Please refer to the following table and set the parameter correctly for enable/disable of Buffer tank (Par5111), the Main water pump setting (Par4200), and additional water pump setting (Par4220, 4221, 5148, 5149).

	Par5111 Buffer temp.	Par5107 DHW temp.	Par4100 HP unit ON/OFF	Par4200 Main water pump	Par4220,4221 additional water pump
1) Outgoing water temp.	0=disable		1=Water set point	0=always ON 2=sniffing cycles	
2) Outgoing water temp. and Room air temp.			0=Room set point		
3) Buffer tank temp.	1=enable		1=Water set point	0=always ON 1=Buffer tank temp. 2=Sniffing cycles	4=based on room temp.
4) Buffer tank temp. and Room air temp.			0=Room set point		
5) DHW tank temp.		1=enable			

Parameters

Level	Parameter		Function description	Display & Input value				Remarks
	Group	Code		Default	min.	Max.	Unit	
I	41	00	The HP unit turns ON/OFF based on 0=Room set point 1=Water set point	1	0	1	-	To be set to the following combinations Par5111=0 →Par4200=0 or 2 Par5111=1 →Par4200=0 or 1 or 2
I	42	00	Type of configuration of Main water pump1 0=always ON 1=ON/OFF based on Buffer tank temperature 2=ON/OFF based on Sniffing cycles	0	0	2	-	
I	51	07	Terminal 7-8 : DHW tank temperature probe 0=disable 1=enable	0	0	1	-	
I	51	11	Terminal 11-12 : Buffer tank temperature probe 0=disable 1=enable	0	0	1	-	
I	42	20	Type of operation of additional water pump1 0=disable 1=depending on Main water pump setting 2=depending on Main water pump setting but always OFF when the DHW mode is activated 3=always ON, apart if any alarms are activated or if the HP unit is in OFF mode. 4=ON/OFF based on Room air temperature	0	0	4	-	
I	42	21	Type of operation of additional water pump2 0=disable 1=depending on Main water pump setting 2=depending on Main water pump setting but always OFF when the DHW mode is activated 3=always ON, apart if any alarms are activated or if the HP unit is in OFF mode. 4=ON/OFF based on Room air temperature	0	0	4	-	

7. Unit Management

7.2.5.1 HP unit controlled based on Outgoing water temperature

Based on the Outgoing water temperature setting, the compressor is controlled and turned ON/OFF.

Start of operation

When the Outgoing water temperature does not reach the water set point, HP unit is turned ON.

Heating : Outgoing water temp. \leq Water set point (Par2100~2115) – Hysteresis (Par2141)

Cooling : Outgoing water temp. \geq Water set point (Par2120~2135) + Hysteresis (Par2142)

Compressor control

The compressor is controlled so that the Outgoing water temperature can reach the water set point.

When the set water temperature is reached, compressor is halted

With the minimum compressor frequency, if the Outgoing water temperature is in the following conditions, or if the Outgoing water temperature reaches the water set point to protect HP unit, then compressor shall be turned OFF.

Heating : Outgoing water temp. \geq Water set point (Par2100~2115) +1°C

Outgoing water temp. \geq 77.0°C

Cooling : Outgoing water temp. \leq Water set point (Par2120~2135) -1°C

Outgoing water temp. \leq 5.5°C

Compressor OFF→ON control

When the Outgoing water temperature reaches the set point and after the compressor is turned OFF, or when the conditions below are met, the compressor shall be turned ON.

However, the compressor is not turned ON during 3 minutes OFF-ON waiting time.

7.2.5.2 HP unit controlled based on Outgoing water temperature and Room air temperature

Based on the Outgoing water temperature setting, the compressor frequency is turned ON/OFF.

Furthermore, the compressor is turned ON/OFF based on Room air temperature.

Compressor stopped by reaching Room air set point

When the Room air temperature sensor built-in the Remote controller detects that the Room air temperature has reached the Room air set point, the compressor is turned OFF.

Compressor OFF→ON control

After the compressor is turned OFF when the Room air temperature reaches the Room air set point, the compressor shall be turned ON when the following conditions are met.

However, it will not be turned ON if it is OFF by the water set point or during the 3 minute standby period of the compressor OFF→ON, even when based on the Room air set point.

Note: As for the Zone without Remote controller to detect the Room air temperature, it is not possible to turn the compressor ON/OFF based on Room air temperature. Therefore, the compressor can be turned ON/OFF only based on Outgoing water temperature.

7. Unit Management

7.2.5.3 HP unit controlled based on Buffer tank temperature

In order to reach the Buffer tank set point, compressor frequency shall be controlled so that Outgoing water temperature can reach the maximum temperature in Heating mode (75°C) or minimum temperature in Cooling mode (7°C). And, the compressor is turned ON/OFF based on Buffer tank set point being reached as well.

Start of operation

When the Outgoing water temperature does not reach the water set point, HP unit is turned ON.

Compressor control

The compressor is controlled to reach the maximum temperature in Heating mode (75°C) or minimum temperature in Cooling mode (7°C).

When the water set point is reached, compressor is halted

The compressor shall be turned OFF if the Buffer tank set point is reached, or if the Outgoing water temperature is in the following conditions, or the Outgoing water temperature reaches the set point to protect HP unit.

Heating: Buffer tank temp. \geq Buffer tank set point (Par2161)

Outgoing water temp. \geq Maximum Outgoing water set point (75°C) +1°C

Outgoing water temp. \geq 77.0°C

Cooling: Buffer tank temp. \leq Buffer tank set point (Par2162)

Outgoing water temp. \leq Minimum Outgoing water set point (7°C) -1°C

Outgoing water temp. \leq 5.5°C

Compressor OFF→ON control

When the Buffer tank temperature reaches the set point, or when the conditions below are met after the compressor is turned OFF due to the set point protecting the HP unit, the compressor is turned ON. However, the compressor is not turned ON during 3 minutes OFF-ON waiting time.

Heating: Buffer tank temp. \leq Buffer tank set point (Par2161) – Hysteresis (Par2141)

Outgoing water temp. \leq Water set point (60°C) – Hysteresis (Par2141)

Outgoing water temp. \leq 57.5°C

Cooling: Buffer tank temp. \geq Buffer tank set point (Par2162) + Hysteresis (Par2142)

Outgoing water temp. \geq Water set point (7°C) + Hysteresis (Par2142)

Outgoing water temp. \geq 7.0°C

7. Unit Management

7.2.5.4 HP unit controlled based on Buffer tank temperature and Room air temperature

In order to reach the Buffer tank set point, compressor frequency shall be controlled so that Outgoing water temperature can reach the maximum temperature in Heating mode (75°C) or minimum temperature in Cooling mode (7°C).

And, the compressor is turned ON/OFF based on Buffer tank set point being reached as well.

Furthermore, additional water pump in Zone1 and Zone2 can be turned ON/OFF.

In order to use this function, Par4220,4221 shall be set as 4 (ON/OFF based on Room air temperature), and the settings to enable the additional water pump in each Zone by Par5148 and Par5149.

* Please refer to 7.5.7.1 and 7.5.7.2.

Additional water pump OFF by reaching set Room air temperature

When the Room air temperature sensor built-in the Remote controller detects that the Room air temperature has reached the Room air set point, the additional water pump in the applicable Zone shall be turned OFF.

Heating : Room air temp. \geq Room air set point (Par0111, 0112, 1101, 1102, 1111, 1112,....1291, 1292)

Cooling : Room air temp. \leq Room air set point (Par0111, 0112, 1101, 1111, 1112,....1291, 1292)

Additional water pump OFF→ON control

After the compressor has been turned OFF when the Room air temperature reaches the Room air set point, the compressor will be turned ON when the following conditions are met.

However, it will not turn ON if it is OFF by the water set point or during the 3 minute standby period of the compressor OFF→ON, even when turned ON by the Room air set point.

Heating : Room air temp. \leq Room air set point (Par0111, 0112, 1111, 1112,....1291, 1292) - Hysteresis (Par4101)

Cooling : Room air temp. \geq Room air set point (Par0111, 0112, 1111, 1112,....1291, 1292) + Hysteresis (Par4102)

Note: As for the Zone without Remote controller to detect the Room air temperature, it is not possible to turn the compressor ON/OFF based on Room air temperature. Therefore, the compressor can be turned ON/OFF only based on Outgoing water temperature.

7. Unit Management

7.2.5.5 HP unit controlled based on DHW tank temperature

DHW tank set point can be selected from Comfort, Economy, or Force.

In order to reach the DHW tank set point, compressor frequency shall be controlled so that Outgoing water temperature can reach the maximum temperature in Heating mode (75°C).

And, the compressor is turned ON/OFF if the DHW tank temperature reaches the set point.

Start of operation

When the DHW tank temperature does not reach the DHW set point, HP unit is turned ON.

Comfort : DHW tank temp. \leq DHW Comfort set point (Par3111) – Hysteresis (Par3113)

Economy : DHW tank temp. \leq DHW Economy set point (Par3112) – Hysteresis (Par3113)

Force : DHW tank temp. \leq DHW Over boost set point (Par3114) – Hysteresis (Par3115)

Compressor control

The compressor is controlled to reach the maximum temperature in Heating mode (75°C).

When the water set point is reached, compressor is halted.

The compressor shall be turned OFF if the DHW tank set point is reached, or if the Outgoing water temperature is in the following conditions, or the Outgoing water temperature reaches the set point to protect HP unit.

Comfort: DHW tank temp. \geq DHW Comfort set point (Par3111)

Economy: DHW tank temp. \geq DHW Economy set point (Par3112)

Force: DHW tank temp. \geq DHW Over boost set point (Par3114)

Outgoing water temp. \geq 77.0°C

Compressor OFF→ON control

When the DHW tank temperature reaches the water set point, or when the conditions below are met after the compressor is turned OFF due to the set point to protect HP unit, the compressor is turned ON.

However, the compressor is not turned ON during 3 minutes OFF-ON waiting time.

Comfort: DHW tank temp. \leq DHW Comfort set point (Par3111) – Hysteresis (Par3113)

Economy: DHW tank temp. \leq DHW Economy set point (Par3112) – Hysteresis (Par3113)

Force: DHW tank temp. \leq DHW Over boost set point (Par3114) – Hysteresis (Par3115)

Outgoing water temp. \leq Water set point (60°C) – Hysteresis (Par2141)

Outgoing water temp. \leq 57.5°C

Note: In case the Outdoor temperature is lower than -5°C, HP unit can change the set point of Outgoing water temperature if the Heating capacity of HP unit decreases.

By this function, DHW can be switched to Heating/Cooling operation before maximum time for DHW (Par3121=60min) elapses.

7. Unit Management

Based on water temperature

Heating mode

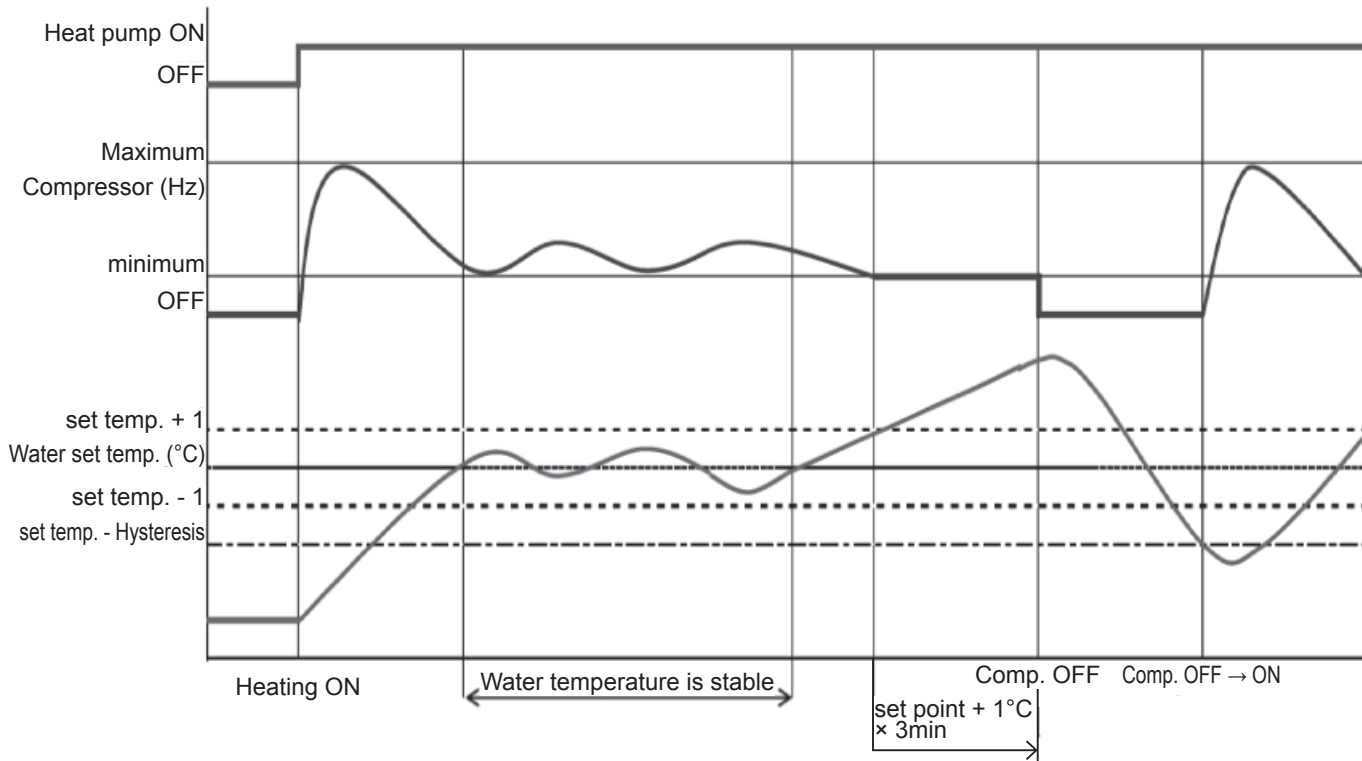

Cooling mode

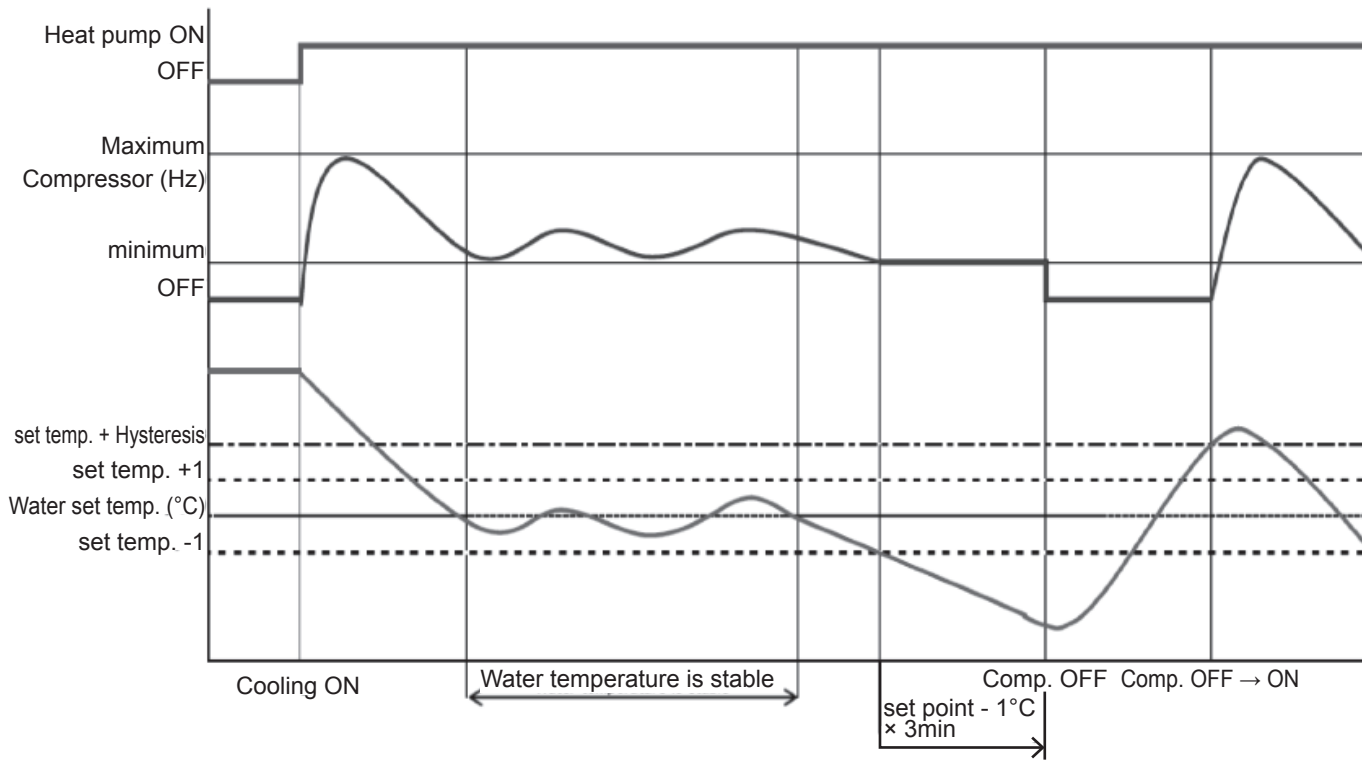

7. Unit Management

7.3 Water pump management

7.3.1 Main water pump

Fundamentally, ON/OFF of the Main water pump links to ON/OFF of the compressor, but the setting ON/OFF of the pump during compressor OFF states, due to reaching the Room set point shall be set in the following parameters;

- Always ON, apart if any alarms are active or if the HP unit is in OFF mode
- ON/OFF based on Buffer tank temperature
- ON/OFF based on Sniffing cycle

If the Buffer tank temperature probe is enabled, the Main water pump turns ON if the Buffer tank temperature is lower than Outgoing water set point (Fixed or calculated by Climatic curve) – Hysteresis, in Heating mode, or higher than Outgoing water set point (Fixed or calculated by Climatic curve) + Hysteresis, in Cooling mode. When the Buffer tank temperature reached the set point (Fixed or calculated by Climatic curve), the main pump turns OFF.

Parameters

Level	Parameter		Function description	Display & Input value				Remarks
	Group	Code		Default	min.	Max.	Unit	
I	42	00	Type of configuration of Main water pump. <u>0=Always ON</u> 1=ON/OFF based on Buffer tank temperature 2=ON/OFF based on Sniffing cycle	0	0	2	-	To be set to the following combinations. Par5111=0 →Par4200=0 or 2
I	51	11	Terminal 11-12 : Buffer tank temperature probe <u>0=disable</u> 1=enable	0	0	1	-	Par5111=1 →Par4200=0 or 1 or 2

7.3.1.1 Continuous operation “Always ON”

When the HP unit is set to “Heating” or “Cooling” mode (i.e. not in standby) the Main water pump will always remain ON.

When the HP unit is set to standby, the pump will remain OFF and will only be started in the conditions described in paragraph on 7.4 Frost protection.

7.3.1.2 Sniffing operation “Sniffing cycle”

In order to minimise energy consumption, the Main water pump can be configured to start only when there is demand from the temperature controller.

The pump will be activated periodically, for a time set by parameter. Five seconds before the cycle ends, if the Outgoing water temperature is lower than “water set point – hysteresis”, in Heating mode, or higher than “water set point + hysteresis” in Cooling mode, the compressor will be activated and the pump will remain ON. When the compressor stops, the pump will continue running for a time set by parameter, after which it will be switched OFF and will repeat the Sniffing cycles.

The interval between one Sniffing cycle and the next is set by a parameter.

Note1: the “Sniffing cycle” is allowed only for space Heating/Cooling. If the HP unit is working to produce DHW the Main water pump has to run continuously.

7. Unit Management

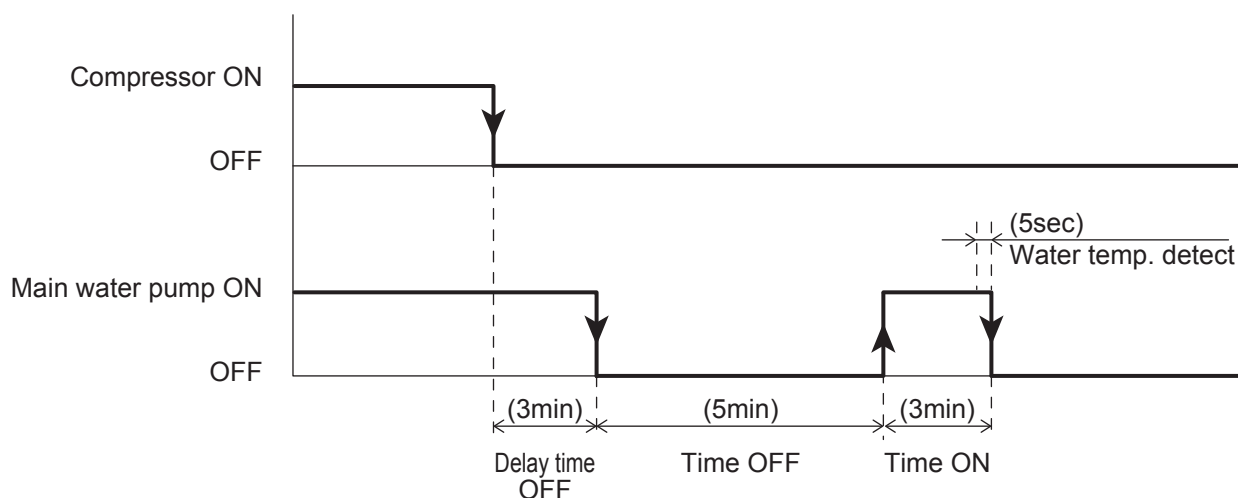

Parameters

Level	Parameter		Function description	Display & Input value				Remarks
	Group	Code		Default	min.	Max.	Unit	
I	42	00	Type of configuration of Main water pump 0=always ON 1=ON/OFF based on Buffer tank temperature 2=ON/OFF based on Sniffing cycle	0	0	2	-	To be set to the following combinations. Par5111=0 →Par4200=0 or 2 Par5111=1 →Par4200=0 or 1 or 2
I	42	01	Time ON Main water pump for Sniffing cycle.	3	1	15	1min	
I	42	02	Time OFF Main water pump	5	5	30	1min	
I	42	03	Delay time OFF Main water pump from OFF compressor	3	1	15	1min	
I	51	11	Terminal 11-12 : Buffer tank temperature probe 0=disable 1=enable	0	0	1	-	

7.3.1.3 Unlock pump function

When the HP unit is stopped for more than 48 hours, the Main water pump turns ON for few seconds to prevent locking up and increases the life time of the pump.

In the case of the main pump/pump1/pump2, the down time after the previous operation stop is counted individually. Furthermore, the pump operation time can be set individually to prevent locking.

Parameters

Level	Parameter		Function description	Display & Input value				Remarks
	Group	Code		Default	min.	Max.	Unit	
I	42	11	OFF time for Unlock pump function start.	48	0	240	1Hr	
I	42	12	Time ON Main water pump for Unlock pump function.	5	0	10	1sec	
I	42	13	Time ON water pump1 for Unlock pump function.	5	0	10	1sec	
I	42	14	Time ON water pump2 for Unlock pump function.	5	0	10	1sec	

7. Unit Management

7.3.1.4 Pump output adjustment function

If an excessive flow rate occurs due to low pressure loss of the circulating loop, adjust the Main water pump output so that the flow rate is reduced.

Using the Dip switch on the PCB(Terminal), 3-level setting is possible.

Be aware that an excessively low flow rate may cause problems including diminished capacity, poor circulation, unavailable flow switch control, and freezing of the water heat exchanger.

SW5, SW6: To switch flow rate (3 Levels of speed) of Main water pump in the HP unit.

At the factory shipment, both SW5 and SW6 are OFF, which means Level 3. (If both are ON, it is Level 3.)

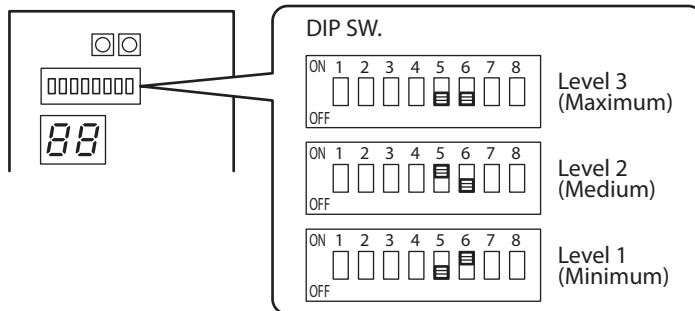

AEYC-0449ZU-CH1, AEYC-0649ZU-CH

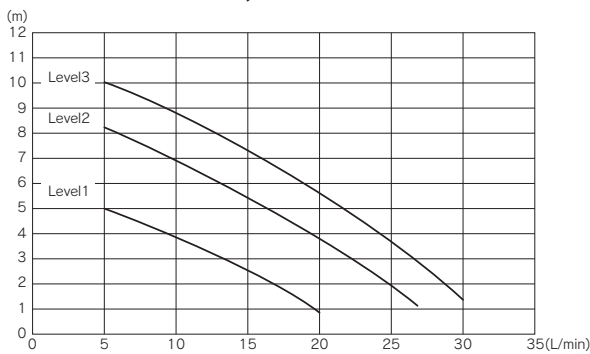

CAUTION

The quantity should not be less than 5L/min. Insufficient water flow may damage the water circulating circuit. If a flow rate becomes lower than the minimum flow rate, an alarm may go off, and a heat pump may stop operation to prevent damage to the unit.

AEYC-0649ZU-CH1, AEYC-0849ZU-CH

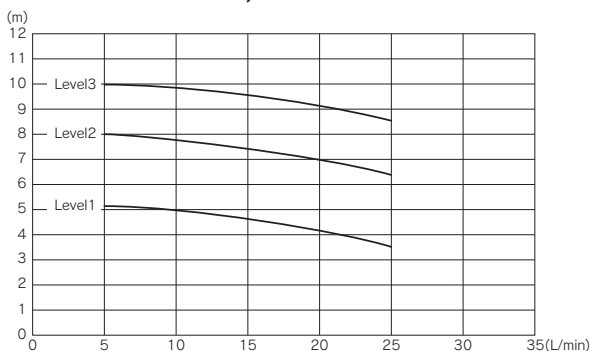

CAUTION

The quantity should not be less than 5L/min. Insufficient water flow may damage the water circulating circuit. If a flow rate becomes lower than the minimum flow rate, an alarm may go off, and a heat pump may stop operation to prevent damage to the unit.

AEYC-1049ZU-CH1, AEYC-1249ZU-CH

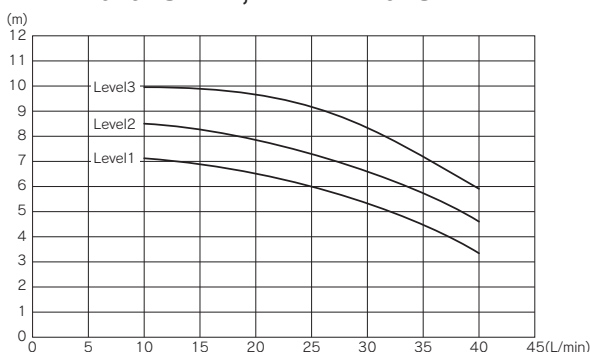

CAUTION

The quantity should not be less than 10L/min. Insufficient water flow may damage the water circulating circuit. If a flow rate becomes lower than the minimum flow rate, an alarm may go off, and a heat pump may stop operation to prevent damage to the unit.

7. Unit Management

7.4 Frost protection

Frost protection can be activated when the HP unit is in OFF mode.
This is controlled based on either the Outgoing water or air temperature:

- Frost protection based on Room air temperature
- Frost protection based on Outdoor air temperature
- Frost protection based on Outgoing water temperature
- DHW tank frost protection
- Secondary system circuit frost protection

7.4.1 Frost protection based on Room air temperature

The purpose of this function is to protect the room from freezing when in OFF mode. When active, it uses the available heat sources configured for normal management of the Heating system (HP unit, alternative heat source).

Note1: The HP unit will operate based on the Frost protection set point, if this shuts down (high pressure switch activation, shut down due to heat exchanger Outgoing water temperature etc.), the other available heat sources will be activated.

Note2: Additional water pumps 1 and 2 are tuned "ON" together with the main pump.

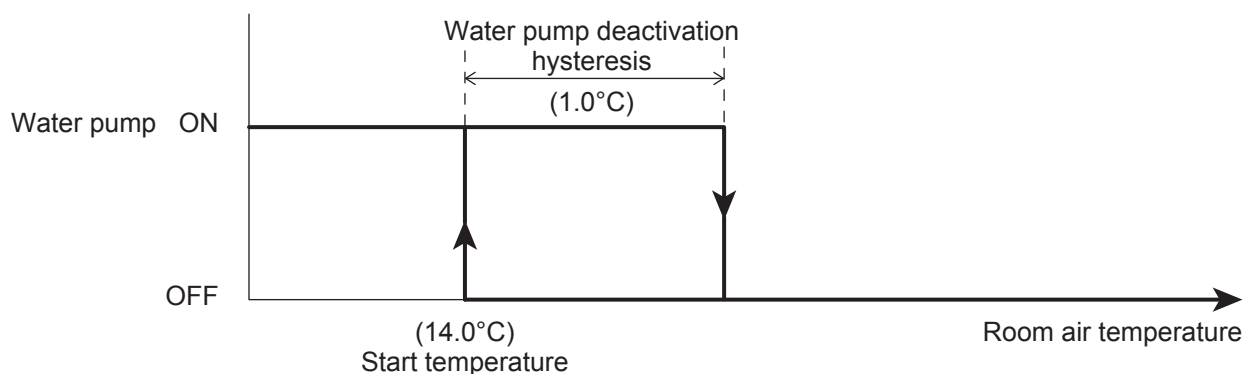

Parameters

Level	Parameter		Function description	Display & Input value				Remarks
	Group	Code		Default	min.	Max.	Unit	
I	43	00	Frost protection on room temperature 0=disable 1=enable	1	0	1	-	
I	43	01	Start temperature of Frost protection on Room air temperature	14.0	0.0	40.0	0.5°C	
I	43	02	Hysteresis of Room air temperature of Frost protection	1.0	0.5	5.0	0.5°C	
I	43	03	Water temperature of frost protection	35.0	10.0	75.0	0.5°C	
I	43	04	Delay time OFF main pump from OFF Frost protection operation function	30	0	120	1sec	

7. Unit Management

7.4.2 Frost protection based on Outdoor air temperature

The Frost protection function is always active, even when the heat pump is OFF.

The water pump is activated if the Outdoor air temperature measure by the HP unit built-in Outdoor temperature sensor is less than the start temperature and deactivated when the Outdoor air temperature rises back “Outdoor air temperature set point + Hysteresis”.

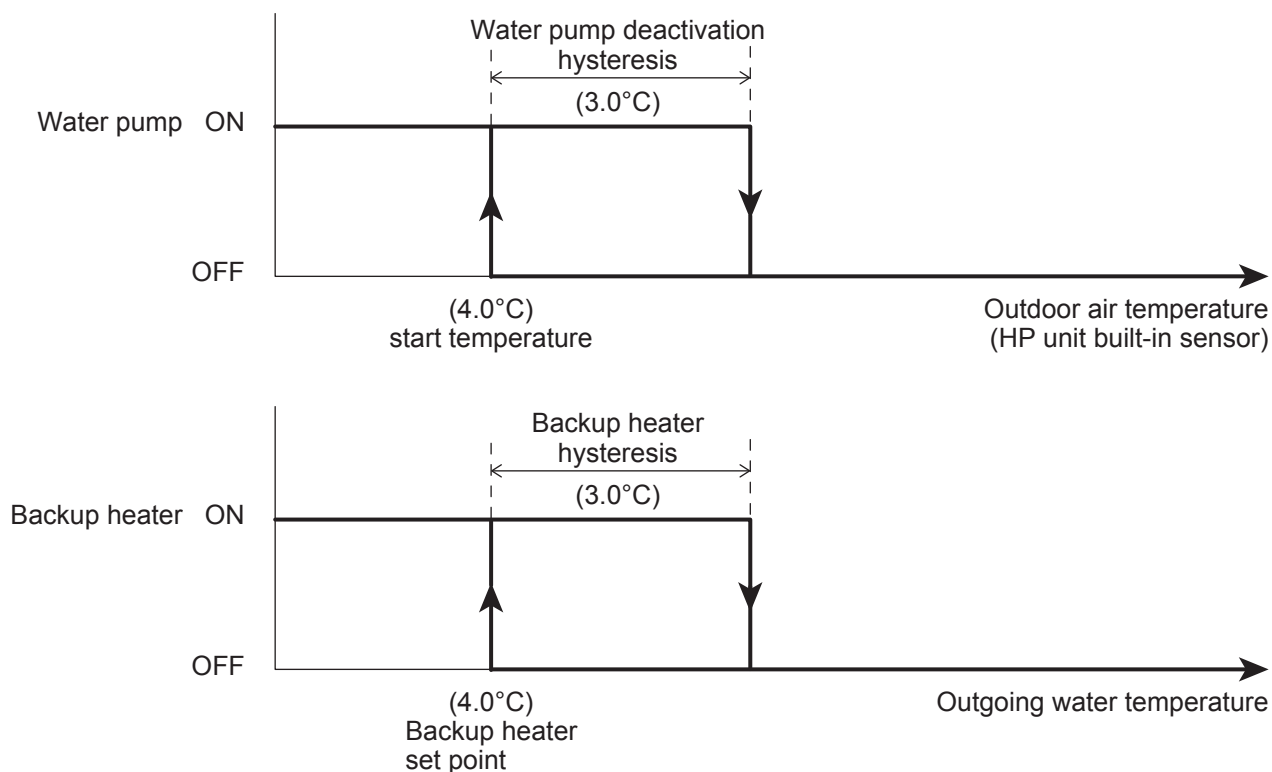

Note1: The additional water pump will be “ON”.

Note2: When the Backup heater enabled, and Frost protection is turned ON, the heater to heat the water will be activated if the Outgoing water temperature is lower than 4°C and it will be stopped if the Outgoing water temperature reaches the 7°C (hysteresis 3°C).

Parameters

Level	Parameter		Function description	Display & Input value				Remarks
	Group	Code		Default	min.	Max.	Unit	
I	43	10	Frost protection by Outdoor air temperature 0=disable 1=enable	1	0	1	-	
I	43	11	Start temperature of Frost protection on Outdoor air temperature	4.0	0.0	10.0	0.5°C	
I	43	12	Hysteresis of Outdoor air temperature	3.0	0.5	5.0	0.5°C	
I	43	13	Backup heater set point during Frost protection	4.0	0.0	10.0	0.5°C	
I	43	14	Hysteresis of Outgoing water temperature	3.0	0.5	5.0	0.5°C	
I	51	46	Terminal 46 : DHW Electric heater or Backup heater 0=DHW Electric heater 1=Backup heater	0	0	1	-	

7. Unit Management

7.4.3 Frost protection based on Outgoing water temperature

The frost protection function is always active, even when the heat pump is OFF.

The water pump is activated if the Outgoing water temperature is less than the start temperature and deactivated when the Outgoing water temperature rises back “Outgoing water temperature set point + Hysteresis”

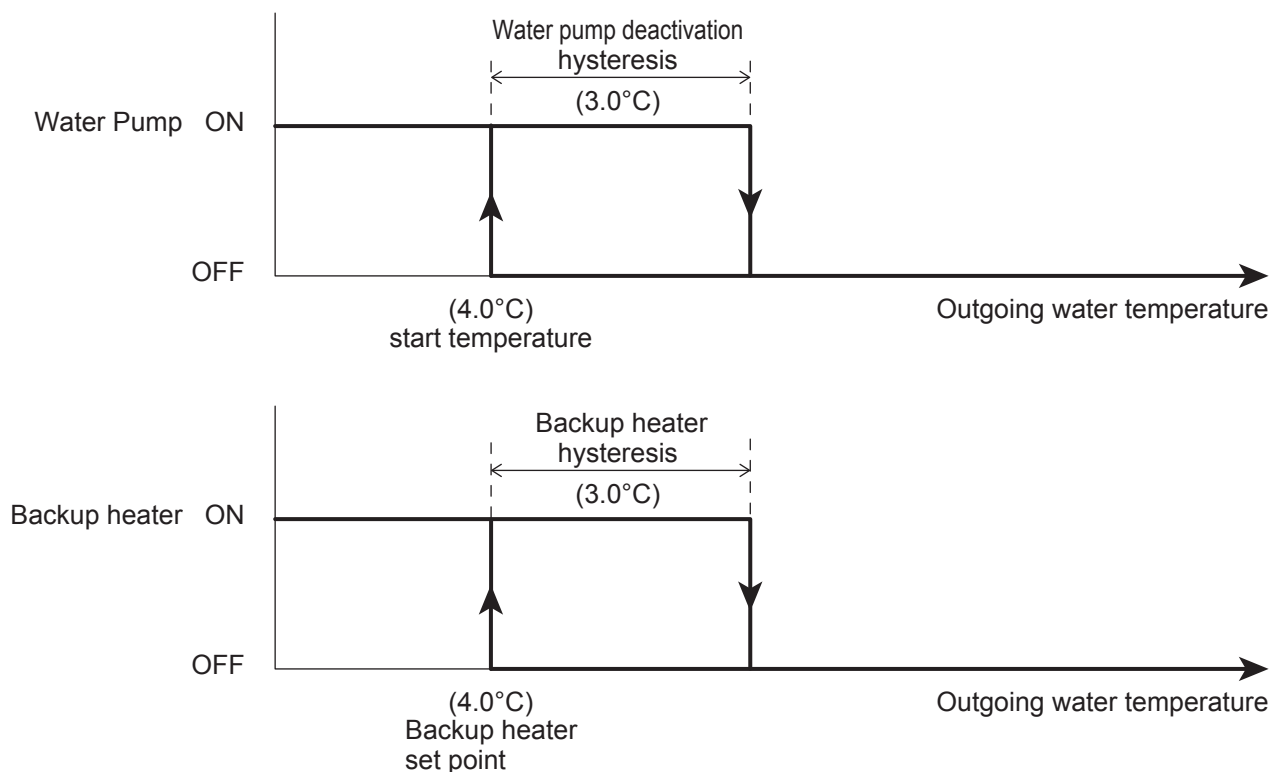

Note1: The additional water pump will be “ON”.

Note2: When the Backup heater is enabled, and Frost protection is turned ON, the heater to heat the water will be activated if the Outgoing water temperature is lower than 4°C and it will be stopped if the Outgoing water temperature reaches.

Parameters

Level	Parameter		Function description	Display & Input value				Remarks
	Group	Code		Default	min.	Max.	Unit	
I	43	20	Frost protection based on Outgoing water temperature 0=disable 1=enable	1	0	1	-	
I	43	21	Start temperature of Frost protection on Outgoing water temperature	4.0	0.0	10.0	0.5°C	
I	43	22	Hysteresis of Outgoing water temperature	3.0	0.5	5.0	0.5°C	
I	43	13	Backup heater set point during Frost protection	4.0	0.0	10.0	0.5°C	
I	43	14	Hysteresis of Outgoing water temperature	3.0	0.5	5.0	0.5°C	
I	51	46	Terminal 46 : DHW Electric heater or Backup heater 0=DHW Electric heater 1=Backup heater	0	0	1	-	

7. Unit Management

7.4.4 DHW tank frost protection

The purpose of this function, is to protect the DHW tank against the formation of ice, activating the Electric heater according to the function described in the following graph.

This function is carried out only by the DHW Electric heater, therefore this needs to be configured by Par5146=0.

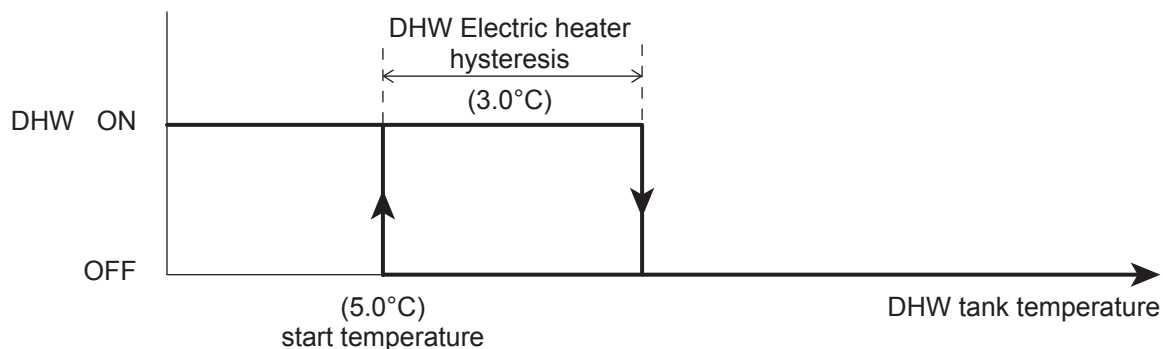

Note1: The function is active even when the unit is switched OFF.

Note2: "DHW tank frost protection" is available only if there is an electric element in DHW tank.

Parameters

Level	Parameter		Function description	Display & Input value				Remarks
	Group	Code		Default	min.	Max.	Unit	
I	43	31	Start temperature of Frost protection of DHW tank temperature	5.0	0.0	60.0	0.5°C	
I	43	32	Hysteresis of DHW tank temperature	3.0	0.5	5.0	0.5°C	
I	51	46	Terminal 46 : DHW Electric heater or Backup heater 0=DHW Electric heater 1=Backup heater	0	0	1	-	

7.4.5 Secondary system circuit frost protection

The additional pumps will be activated together with the main pump in frost protection. If not during frost protection, the additional pumps will be activated according to the setting of Par4220,4221.

7. Unit Management

7.5 Input/Output contact

7.5.1 Heating/Cooling mode remote contact

Heating/Cooling operating mode can be managed from a remote contact.

If remote Heating/Cooling changeover is enabled by Par5124, the operating mode cannot be changed by the Remote controller.

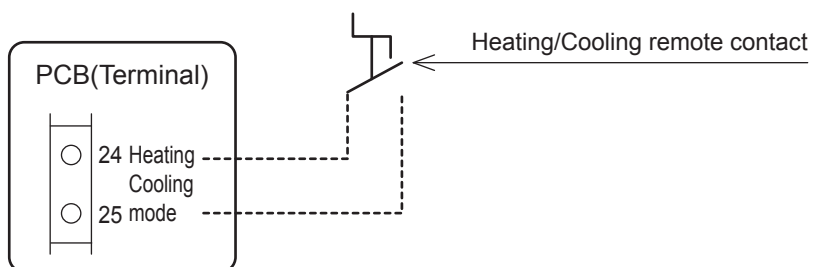

Note: Heating/Cooling remote contact will be used when the operation of HP unit is turned ON by ON/OFF remote contact. It is not available if ON/OFF remote contact is OFF, and set Par5120=0.

Parameters

Level	Parameter		Function description	Display & Input value				Remarks
	Group	Code		Default	min.	Max.	Unit	
I	31	01	DHW production priority setting 0=DHW is unavailable 1=DHW is available, and priority DHW over space Heating 2=DHW is available, and priority space Heating over DHW	0	0	2	-	
I	51	20	Terminal 20-21 : ON/OFF remote contact or EHS Alarm input 0=disable (Remote controller only) 1=ON/OFF remote contact 2=EHS Alarm input	0	0	2	-	ON/OFF by Remote controller 0=enable 1=ON/disable OFF/enable 2=enable
I	51	24	Terminal 24-25 : Heating/Cooling mode remote contact 0=disable (Remote controller only) 1=Cooling is CLOSE contact, Heating is OPEN contact 2=Cooling is OPEN contact, Heating is CLOSE contact	0	0	2	-	

7. Unit Management

7.5.2 ON/OFF DHW production remote contact

The enabling of the DHW production can be managed from remote contact.

If the remote ON/OFF DHW changeover is enabled by Par5119, the DHW mode cannot be changed by the Remote controller. When DHW is turned ON by remote contact with the HP unit ON state, HP unit will start operation in Comfort mode.

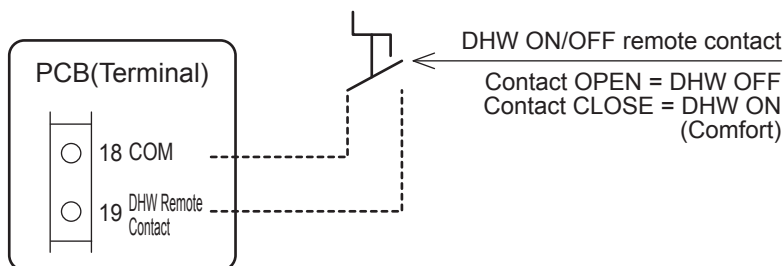

Note1: DHW function can be used by the DHW remote contact.

If the Remote controller is not connected, turn ON HP unit by ON/OFF remote contact first.

If the Remote controller is connected, turn ON both Remote controller by ON/OFF button and ON/OFF remote contact, then turn ON HP unit.

Parameters

Level	Parameter		Function description	Display & Input value				Remarks
	Group	Code		Default	min.	Max.	Unit	
I	31	01	DHW production priority setting 0=DHW is <u>unavailable</u> 1=DHW is available, and priority DHW over space Heating 2=DHW is available, and priority space Heating over DHW	0	0	2	-	In order to use DHW function, it is necessary to set Par3101=1 or2 Par5107=1
I	51	07	Terminal 7-8 : DHW tank temperature probe 0= <u>disable</u> 1=enable	0	0	1	-	
I	51	19	Terminal 19-18 : DHW remote contact 0= <u>disable (Remote controller only)</u> 1=enable	0	0	1	-	

7. Unit Management

Priority of DHW production mode

The top priority is “by time band”, the second priority is “by remote contact”, then “by button of Remote controller”. If DHW production is operated by using the remote, the setting temperature shall be “Comfort”.

DHW mode states			Turn ON/OFF DHW by remote contact		DHW mode states based on priority	
by button	by time band				by remote contact	by time band
Force	no activated	→	turn ON	→	Comfort (Force*)	
			turn OFF	→	OFF	
Comfort	no activated	→	turn ON	→	Comfort	
			turn OFF	→	OFF	
Economy	no activated	→	turn ON	→	Comfort (Economy*)	
			turn OFF	→	OFF	
no activated	Comfort	→	turn ON	→		Comfort
			turn OFF			
no activated	Economy	→	turn ON	→		Economy
			turn OFF			
no activated	no activated	→	turn ON	→	Comfort	
			turn OFF	→	OFF	

(*) During Force or Economy mode by the Remote controller button, if Par5119 is changed from 0 to 1 and then DHW remote contact is changed to ON, HP unit will continue Force or Economy operation. Once DHW mode is stopped, then, DHW mode by remote contact will be operated with Comfort set point.

7. Unit Management

7.5.3 ON/OFF remote contact

HP unit can be turned ON/OFF by remote contact with timer or thermostat in the room.

In case the Remote controller is not connected, HP unit will be turned ON/OFF according to remote contact.

In case the Remote controller is connected, if both Remote controller and remote contact are not ON, HP unit will not be turned ON.

During operation with both the Remote controller and remote contact ON, if one of either the Remote controller or remote contact is turned OFF, then the HP unit will be turned OFF as well.

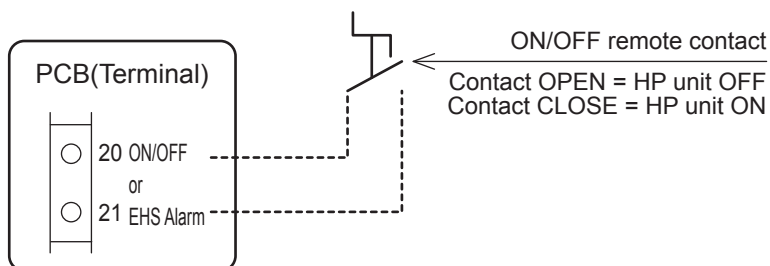

HP unit states by ON/OFF of Remote controller and remote contact

Remote controller connected				Remote controller not connected		
Remote controller	remote contact		HP unit states	remote contact		HP unit states
ON	ON	→	ON	ON	→	ON
ON	OFF	→	OFF	OFF	→	OFF
OFF	ON	→	OFF			
OFF	OFF	→	OFF			

Note: The frost protection is active even when the unit is switched OFF from the remote contact.

Parameters

Level	Parameter		Function description	Display & Input value				Remarks
	Group	Code		Default	min.	Max.	Unit	
I	51	20	Terminal 20-21 : ON/OFF remote contact or EHS Alarm input 0=disable (Remote controller only) 1=ON/OFF remote contact 2=EHS Alarm input	0	0	2	-	ON/OFF by Remote controller 0=enable 1=ON/disable OFF/enable 2=enable

7. Unit Management

Note1: When both the DHW production and ON/OFF remote contact are simultaneously ON, DHW operation has priority.

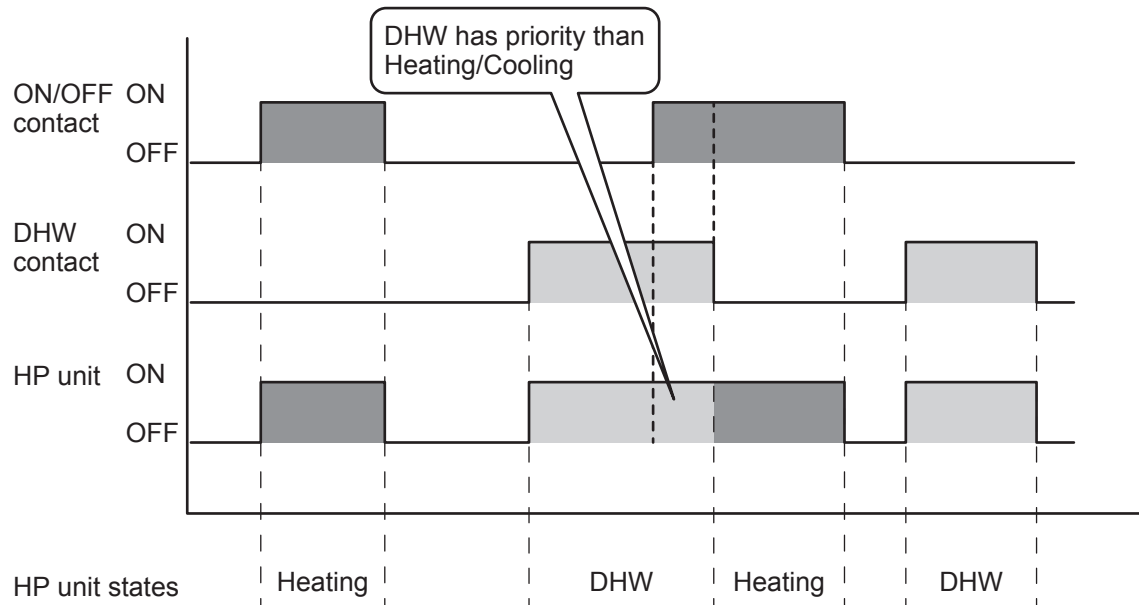

Note2: In case the ON/OFF remote contact is enabled and Heating/Cooling remote contact is disabled (by Remote controller), if the ON/OFF remote contact=ON and Heating or Cooling is in operation, and if the Mode button of Remote controller is used to select OFF among Heating→Cooling→OFF, the ON/OFF remote contact=ON condition will be top priority than the Mode button of Remote controller.

7. Unit Management

7.5.4 EHS Alarm

In case of the hybrid solution, gas boiler + HP unit, the EHS Alarm digital input of the HP unit receives a signal from the boiler in fault, and the HP unit is forced in Heating to heat the water for space Heating or for DHW according the priority setting. The HP unit works to reach the DHW set point or water set point for space Heating, otherwise the compressor will stop.

In order to heat the water also if the external heat source doesn't work because it is faulty.

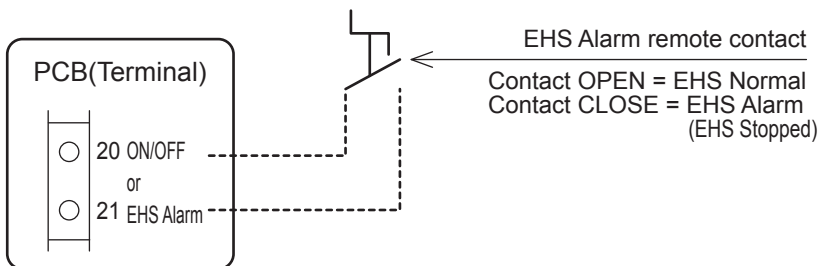

Parameters

Level	Parameter		Function description	Display & Input value				Remarks
	Group	Code		Default	min.	Max.	Unit	
I	51	20	Terminal 20-21 : ON/OFF remote contact or EHS Alarm input 0=disable 1=ON/OFF remote contact 2=EHS Alarm input	0	0	2	-	ON/OFF by Remote controller 0=enable 1=ON/disable OFF/enable 2=enable

7. Unit Management

7.5.5 Flow switch

The flow switch is connected at the terminal on the PCB. When the compressor and pump operate, the adjusted flow rate is reached, the flow switch contact closes, The intent is to protect the plate-to-plate heat exchanger in Cooling mode. Therefore, the flow switch error will be detected only in Cooling mode.

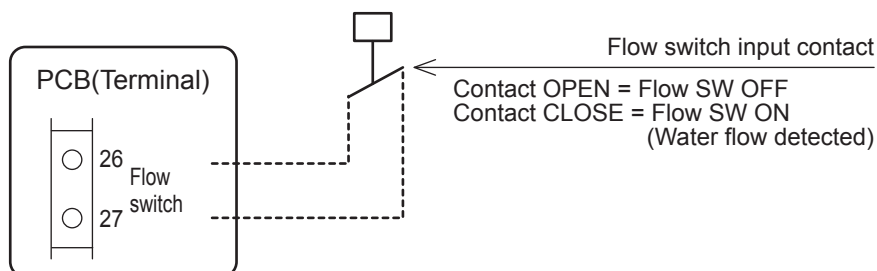

At Start-up, the compressor will not be turned ON unless the flow switch is CLOSED (water flow detected).

After starting operation, once the flow switch is OPEN(no water flow).

In case of Flow switch error for 2min or the system carries out 5 retries within 60min, then an alarm will appear and the compressor will be turned OFF.

From the first error to the fourth error, the compressor will be stopped temporarily and restart automatically after delay time.

When the errors are detected 5 times within 60min, alarm will be displayed and compressor will be stopped.

The alarm is not automatically recovered but shall be reset manually.

After 60min or more from the first error detected, the number of errors will be reset.

Errors up to 4 times within 60min are not displayed on Remote controller, but are recorded in the alarm history.

Parameters

Level	Parameter		Function description	Display & Input value				Remarks
	Group	Code		Default	min.	Max.	Unit	
I	51	26	Terminal 26-27 : Flow switch 0=disable 1=enable	1	0	1	-	

7. Unit Management

7.5.6 Dual set point control

Applies only to installations with different heat emitters which require different set points (e.g. fan coil and floor heating).

Dual set point control makes it possible to generate two different set points. The selection between the two set points is available by the remote contact.

If the Dual set point control contact is CLOSE, the second set point is activated.

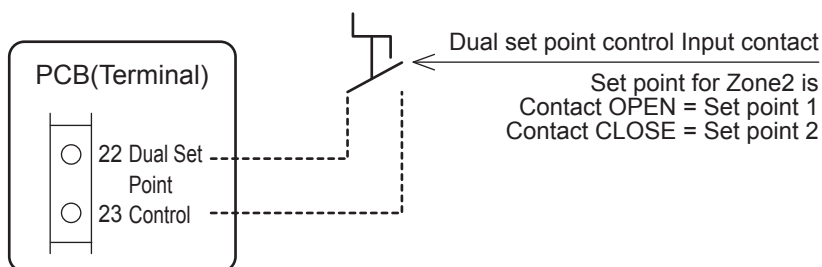

Parameters

Level	Parameter		Function description	Display & Input value				Remarks
	Group	Code		Default	min.	Max.	Unit	
I	51	22	Terminal 22-23 : Dual set point control 0=disable 1=enable	1	0	1	-	

The first set point (Zone1) Heating/Cooling is the set point selected on the Remote controller.

In Heating mode the first set point (Zone1) can be a Fixed value or by Climatic curve.

In Cooling mode the first set point (Zone1) can be a Fixed value or by Climatic curve.

The temperature of the requested water from the HP unit is calculated through a further two Climatic curves (Heating/Cooling), or by a Fixed set point.

The second set point (Zone2) Heating should be linked to the heat emitters which requires the highest set point in Heating mode. Example: fan coil unit.

The second set point (Zone2) Cooling should be linked to the heat emitters which requires the lowest set point in Cooling mode. Example: Dehumidifier.

Note: The second set point (Zone2) is effective only for space Heating/Cooling.

7. Unit Management

7.5.7 Additional water pump

A parameter can be used to set the desired operation:

- Additional water pump1
- Additional water pump2

Parameters

Level	Parameter		Function description	Display & Input value				Remarks
	Group	Code		Default	min.	Max.	Unit	
I	51	48	Terminal 48 : Pump1 0=disable 1=1st Additional water pump1 for Zone1	0	0	1	-	
I	51	49	Terminal 49 : Pump2 0=disable 1=2nd Additional water pump2 for Zone2	0	0	1	-	

7.5.7.1 Additional water pump1

A parameter can be used to set the desired type of pump operation, as follows:

- ① Depending on Main water pump setting
- ② Depending on Main water pump setting but always OFF when the DHW mode is activated
- ③ Always ON, apart from if any alarms are active or if the HP unit is in OFF mode
- ④ ON/OFF based on Room air temperature (set by Remote controller)

Note: As for the above sentence No. ③, "OFF mode" means Power supply for HP unit is ON, and with no operation for Heating/Cooling/DHW.

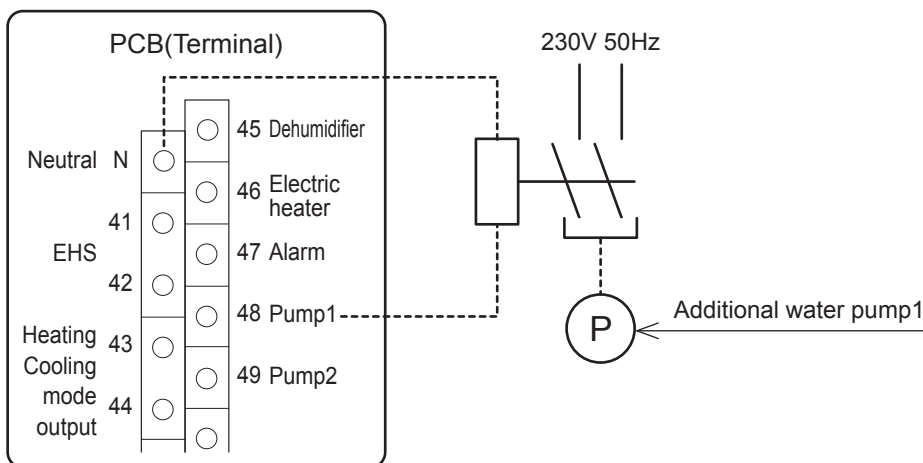

Parameters

Level	Parameter		Function description	Display & Input value				Remarks
	Group	Code		Default	min.	Max.	Unit	
I	51	48	Terminal 48 : Pump1 0=disable 1=1st Additional water pump1 for Zone1	0	0	1	-	
I	42	20	Type of operation of additional water pump1 0=disable 1=depending on Main water pump setting 2=depending on Main water pump setting but always OFF when the DHW mode is activated 3=always ON, apart if any alarms are activated or if the HP unit is in OFF mode 4=ON/OFF based on Room air temperature	0	0	4	-	

7. Unit Management

Scheme <A> set configuration

- ① Depending on Main water pump setting
- ② Depending on Main water pump setting but always OFF when the DHW mode is activated

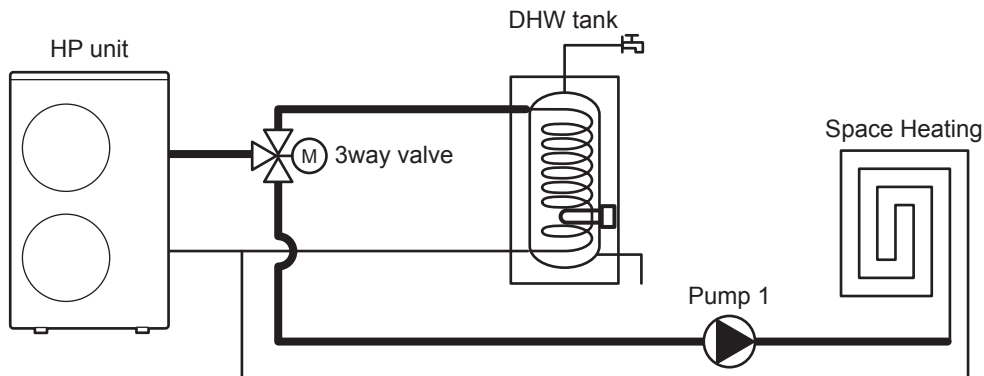

Scheme set configuration

- ① Depending on Main water pump setting
- ② Depending on Main water pump setting but always OFF when the DHW mode is activated
- ③ Always ON, apart from if any alarms are active or if the HP unit is in OFF mode
- ④ ON/OFF based on Room air temperature (set by Remote controller)

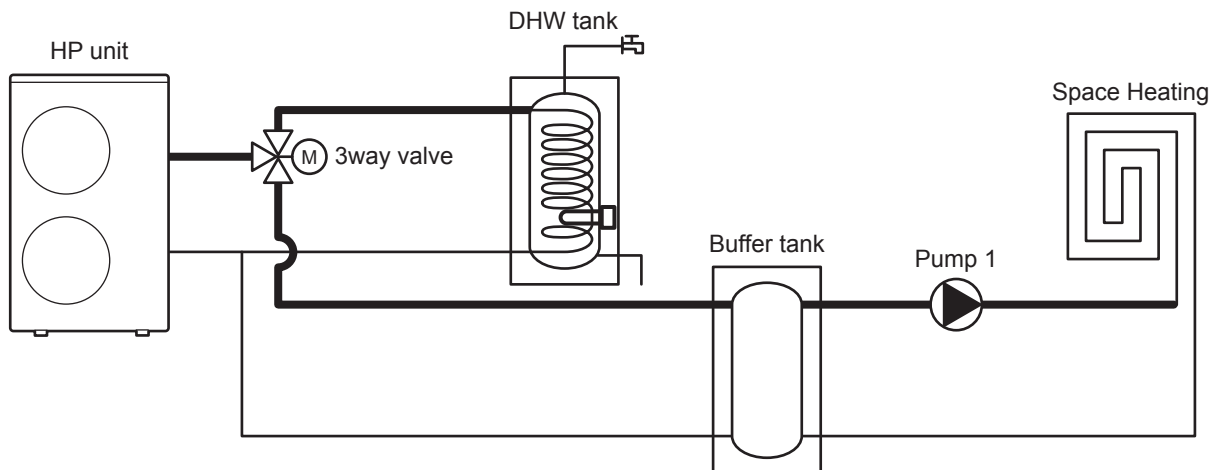

7. Unit Management

7.5.7.2 Additional water pump2

A parameter can be used to set the desired type of pump operation, as follows:

- ① Depending on Main water pump setting
- ② Depending on Main water pump setting but always OFF when the DHW mode is activated
- ③ Always ON, apart from if any alarms are active or if the HP unit is in OFF mode
- ④ ON/OFF based on Room air temperature (set by Remote controller)

Note: As for above sentence No. ③, "OFF mode" means Power supply for HP unit is ON, and with no operation for Heating/Cooling/DHW.

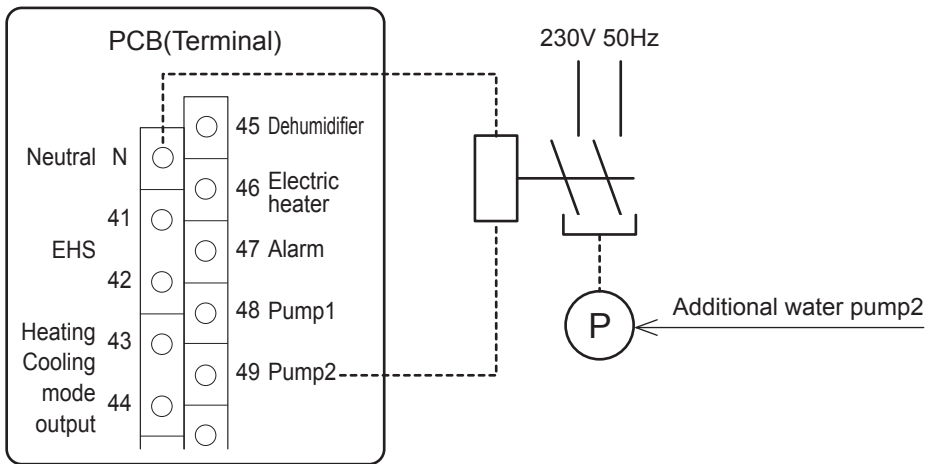

Parameters

Level	Parameter		Function description	Display & Input value				Remarks
	Group	Code		Default	min.	Max.	Unit	
I	51	49	Terminal 49 :Pump2 0=disable 1=2nd Additional water pump2 for Zone2	0	0	1	-	
I	42	21	Type of operation of additional water pump2 0=disable 1=depending on Main water pump setting 2=depending on Main water pump setting but always OFF when the DHW mode is activated 3=always ON, apart if any alarms are activated or if the HP unit is in OFF mode 4=ON/OFF based on Room air temperature	0	0	4	-	

7. Unit Management

Scheme <A> set configuration

- ① Depending on Main water pump setting
- ② Depending on Main water pump setting but always OFF when the DHW mode is activated

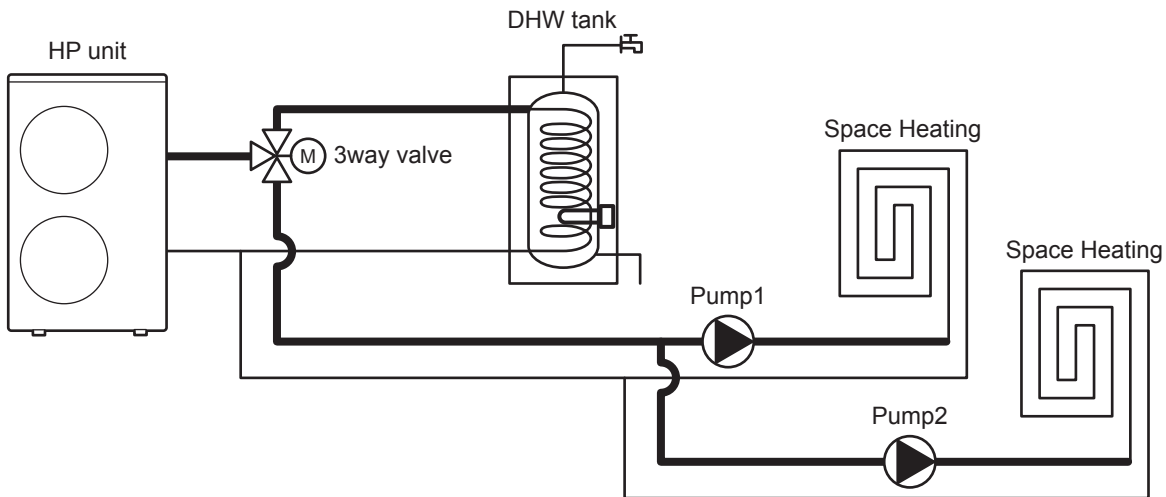

Scheme set configuration

- ① Depending on Main water pump setting
- ② Depending on Main water pump setting but always OFF when the DHW mode is activated
- ③ Always ON, apart from if any alarms are active or if the HP unit is in OFF mode
- ④ ON/OFF based on Room air temperature (set by Remote controller)

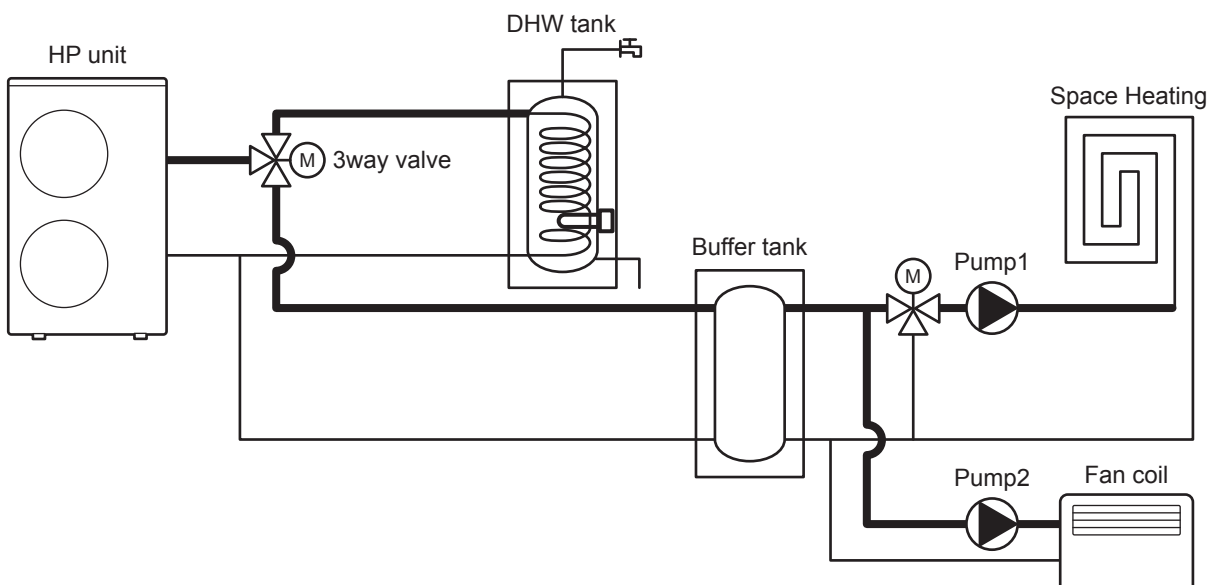

7. Unit Management

7.5.8 Heating/Cooling mode output

The purpose of this output is to communicate signals to an external controller so that the operation mode is displayed in the controller and that the 3way valve can be controlled using the controller.

When space heating is provided through the floor Heating + fan coil units and Cooling is provided with the fan coil units only; during Cooling mode, the floor heating loop should be closed via the 3way valve so that cold water does not run into the floor heating loop. This output allows control of the 3way valve.

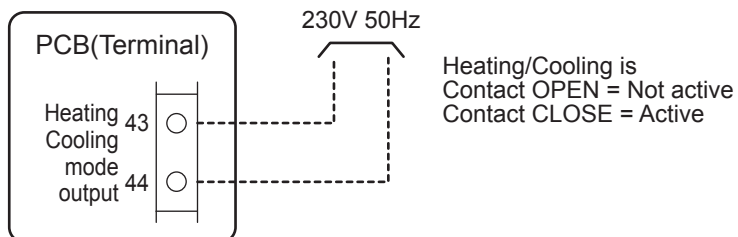

Parameters

Level	Parameter		Function description	Display & Input value				Remarks
	Group	Code		Default	min.	Max.	Unit	
I	51	43	Terminal 43-44 : Heating/Cooling mode output 0=disable 1=Indication of Cooling mode (CLOSE=Cooling) 2=indication of Heating mode (CLOSE=Heating)	0	0	2	-	

7. Unit Management

7.5.9 Configurable contact (Alarm)

This parameter can be used to set the desired operation, as follows:

- Alarm
- Ambient temperature reached

Parameters

Level	Parameter		Function description	Display & Input value				Remarks
	Group	Code		Default	min.	Max.	Unit	
I	51	47	Terminal 47 : Alarm (Configurable output) 0=disable 1=Alarm 2=Ambient temperature reached	0	0	2	-	

7.5.9.1 Alarm

The purpose of this output is to indicate the alarm state. This signal is used by an external controller to verify if the HP unit can operate with the requested function or if the output is possible for the visual signal device.

For all alarms, an output occurs at the Alarm contact.

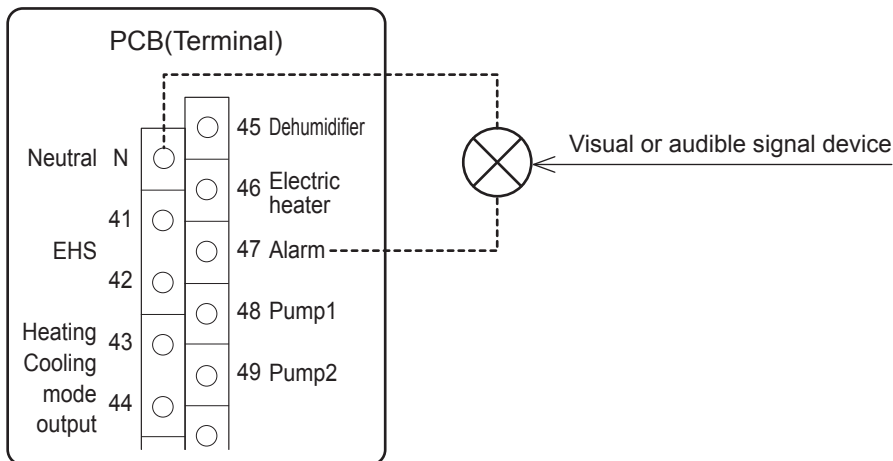
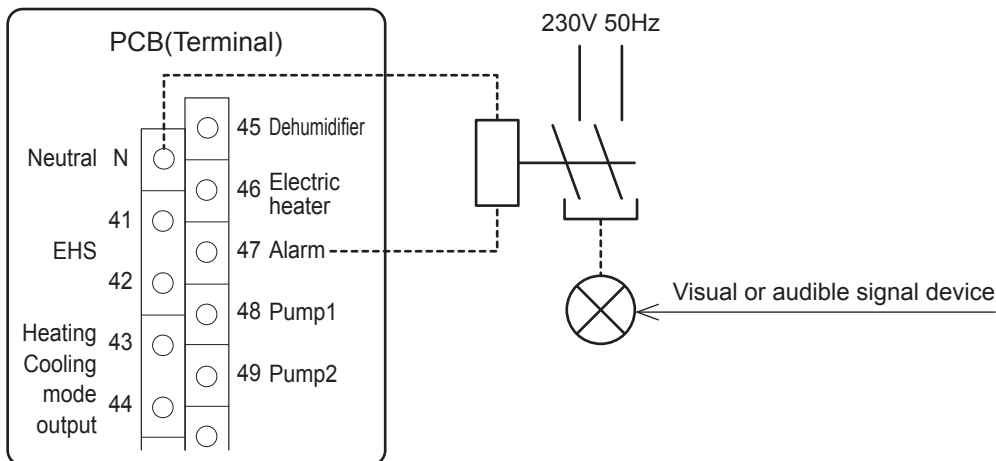

7. Unit Management

7.5.9.2 Ambient temperature reached

The intent of this output is to give a signal to a potential Fan coil system when the Room air temperature, measured by the Remote controller, is reached, so that the Fan coils will stop. When the Fan coil system is restarted by the predetermined Room air temperature hysteresis, transmission of the signal is halted.

This signal can be used like a window contact by the Fan coil to stop the Fan coils and/or water valves.

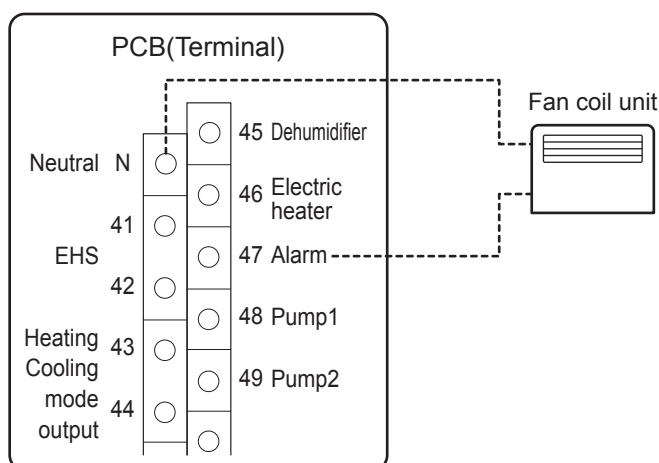

In case of Par0400=1, if the Room air temperature detected by the Remote controller has not reached the set point, the Terminal47 will be closed.

In case of Par0400=2, if one of the Room air temperatures detected by Master or Slave Remote controller has not reached the set point, the Terminal47 will be closed.

Par0400 settings	Room air temperature detected by			Terminal47 contact
	Master Remote controller	Slave Remote controller		
0=Master Remote controller	not reached	-	→	CLOSE
	reached	-	→	OPEN
1=Slave Remote controller	-	not reached	→	CLOSE
	-	reached	→	OPEN
2=Master or Slave Remote controller	not reached	not reached	→	CLOSE
	reached	not reached	→	CLOSE
	not reached	reached	→	CLOSE
	reached	reached	→	OPEN

Parameters

Level	Parameter		Function description	Display & Input value				Remarks
	Group	Code		Default	min.	Max.	Unit	
I	04	00	Which Remote controller will measure the Room air temperature to stop Fan coil system <u>0=Master Remote controller</u> 1=Slave Remote controller 2=Master or Slave Remote controller	0	0	2	-	
I	04	01	Hysteresis of Room air temperature to restart Fan coil system	1.0	0.5	10.0	0.5°C	

7. Unit Management

7.5.10 Night mode

If there is a need to reduce the maximum value of electric and/or noise absorption of the compressor, e.g. in night-time operation, it is possible to activate the Night mode function using the relative external contact (Terminal 28-29) or Low tariff/Night mode button of the Remote controller.

If Night mode function starts, according to a time band, the maximum frequency will be decreased to the value selected on Par4111 in the ON time by time band setting. Otherwise it will operate in normal mode.

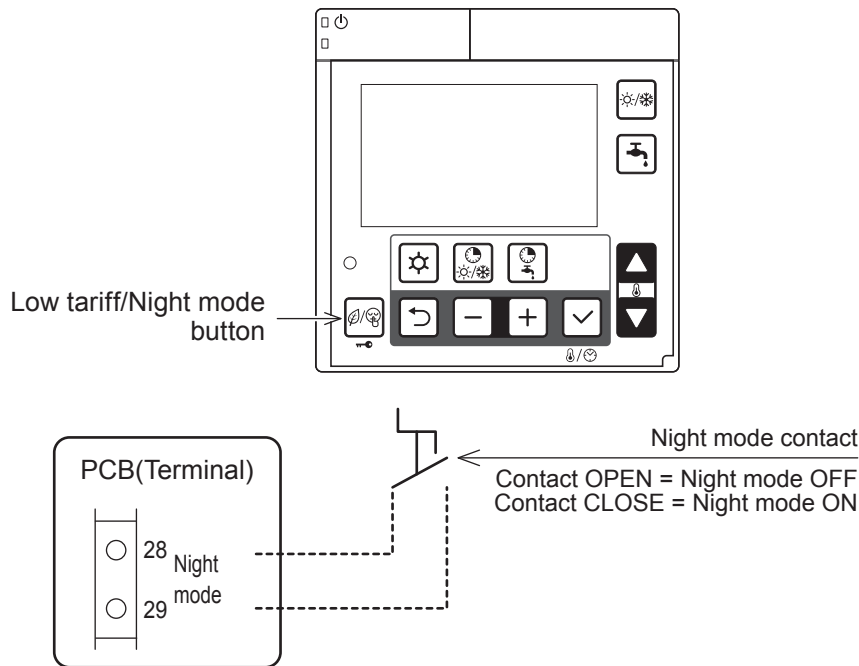

Note1: Par5128 (Night mode) and Par5130 (Low tariff) are automatically synchronized to same value. If Par5128 is changed to 1 (enable), then Par5130 will be also changed to 1 (enable).

Note2: During Night mode with Night mode contact ON, if Par5128 is changed to 0, the HP unit will continue to operate in Night mode. During Night mode by the Remote controller button, if Par5128 is changed to 1, the HP unit will follow the signal of ON/OFF by Night mode contact.

Parameters

Level	Parameter		Function description	Display & Input value				Remarks
	Group	Code		Default	min.	Max.	Unit	
I	51	28	Terminal 28-29 : Night mode 0=disable (Remote controller only) 1=enable	0	0	1	-	Par5128 and Par5130 are synchronized in same value
I	41	11	Max. frequency of Night mode	80	50	100	5%	

7. Unit Management

7.5.11 Low tariff

The purpose of this function, enabled by the digital input (Terminal 30-31) or Low tariff/Night button of the Remote controller, is to force the charge of all buffers in the system and DHW tank and buffer according the specified priorities during times when electricity rates are inexpensive. When the contact is active, the DHW set point switches to the DHW Comfort set point, even if the user has specified operation with the DHW Economy set point, and the DHW tank is filled.

When Low tariff function is activated, in the ON time according to the time band, the Heating/Cooling set point (fixed or calculated by Climatic curve) increases (for Heating)/decreases (for Cooling) by the amount specified by parameter Differential water set point. The difference can be set separately for Heating and Cooling using the relevant parameter.

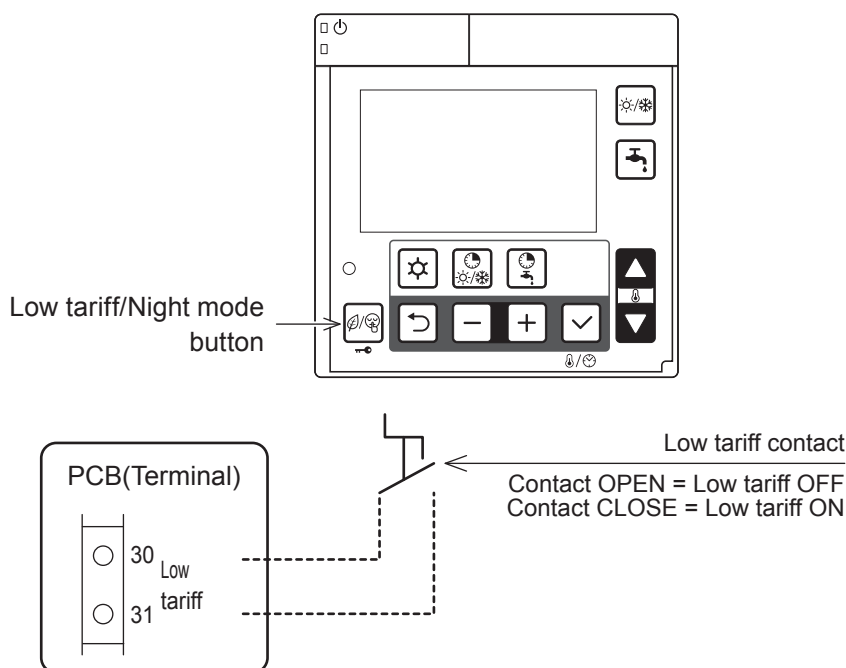

Note1: Par5128 (Night mode) and Par5130 (Low tariff) are automatically synchronized to same value.
If Par5128 is changed to 1 (enable), then Par5130 will be also changed to 1 (enable).

Note2: During Low tariff with Low tariff contact ON, if Par5130 is changed to 0, the HP unit will continue to operate in Low tariff.
During Low tariff by the Remote controller button, if Par5128 is changed to 1, the HP unit will follow the signal of ON/OFF by Low tariff contact.

Parameters

Level	Parameter		Function description	Display & Input value				Remarks
	Group	Code		Default	min.	Max.	Unit	
I	51	30	Terminal 30-31 : Low tariff 0=disable (Remote controller only) 1=enable	0	0	1	-	Par5128 and Par5130 are synchronized in same value
I	21	51	Low tariff deferential water set point for Heating	5.0	0.0	60.0	0.5°C	
I	21	52	Low tariff deferential water set point for Cooling	5.0	0.0	60.0	0.5°C	

7. Unit Management

7.5.12 Dehumidifier management

To adjust ambient humidity, a dehumidifier can be used. Dehumidifier control is possible only during Cooling mode. If dehumidification is required, then its possible to control the dehumidifier through a relay connected between Terminal 45-N.

The dehumidifier managed with humidity sensor. A demand for dehumidification occurs only in Cooling mode.

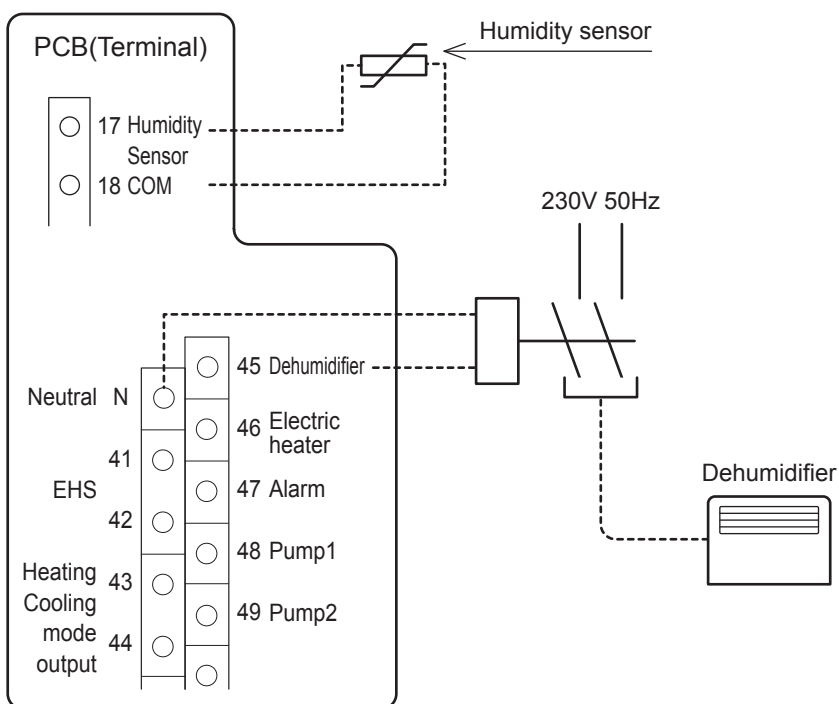

Parameters

Level	Parameter		Function description	Display & Input value				Remarks
	Group	Code		Default	min.	Max.	Unit	
I	51	17	Terminal 17-18 : Humidity sensor 0=disable 1=enable	0	0	1	-	
I	51	45	Terminal 45 : Dehumidifier 0=disable 1=enable	0	0	1	-	

7. Unit Management

The Humidity Sensor connected in the Terminal 17-18. The controller receives the relative humidity signal in the form of voltage signals (DC0~10 V).

The respective room humidity is calculated via the linear characteristic which is defined by 2 fixed points (voltage value1 / function value1 and voltage value2 / function value2).

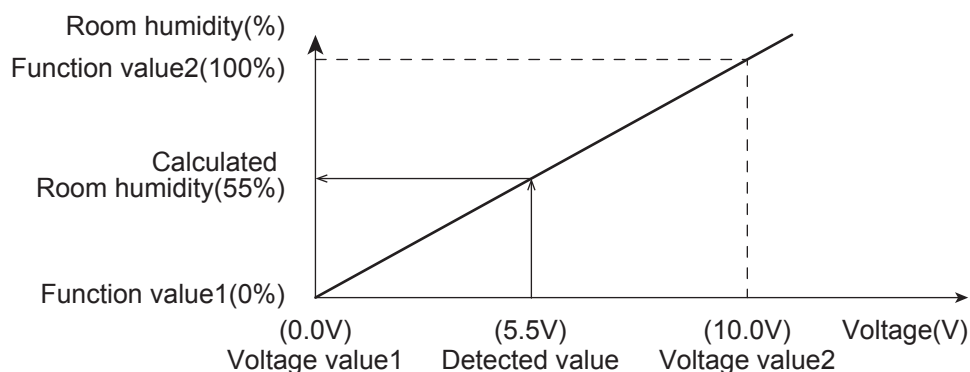

Note: Alarm control logic

PCB(Controller) displays error code L5 (Sensor Humidity failure), when the detected voltage of Humidity sensor (Terminal 17-18) is below DC0.15V or above DC9.8V.

Considering 2% of deviation for PCB circuit, the alarm may be displayed if the humidity is 96% or higher (DC9.6V or higher).

The controller compares room humidity (detected with humidity sensor) with the humidity set point (Par 4401, 4402) and switches the external dehumidifier connected to the Terminal 45-N.

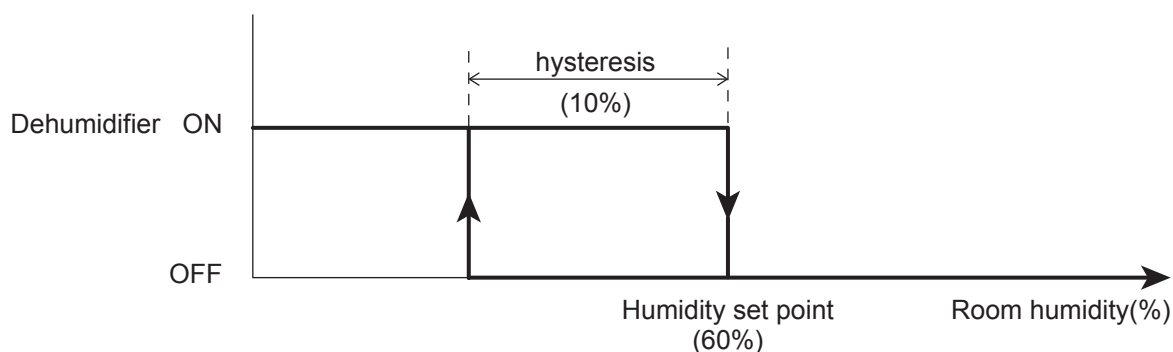

Parameters

Level	Parameter		Function description	Display & Input value				Remarks
	Group	Code		Default	min.	Max.	Unit	
I	44	01	Room relative humidity value	60	0	100	1%	
I	44	02	Hysteresis value	10	1	100	1%	
I	44	03	Humidity sensor property, Voltage value1	0.0	0.0	10.0	0.1V	
I	44	04	Humidity sensor property, Voltage value2	10.0	0.0	10.0	0.1V	
I	44	05	Humidity sensor property, Function value1	0	0	100	1%	
I	44	06	Humidity sensor property, Function value2	100	0	100	1%	

7. Unit Management

Maximum Room humidity compensation

The Outgoing water set point, calculated based on the Climatic curve, can be compensated according to the maximum relative humidity in the room to prevent and to avoid possible formation of condensate in the floor in case of floor cooling system.

If the humidity measured by the humidity sensor exceeds the value specified by Par4410 and 4411, the Outgoing water set point increases until the maximum Outgoing temperature has been reached.

The maximum Outgoing temperature is the set point calculated according to the compensation curve in the Cooling mode + Hysteresis value set by the dedicated parameter.

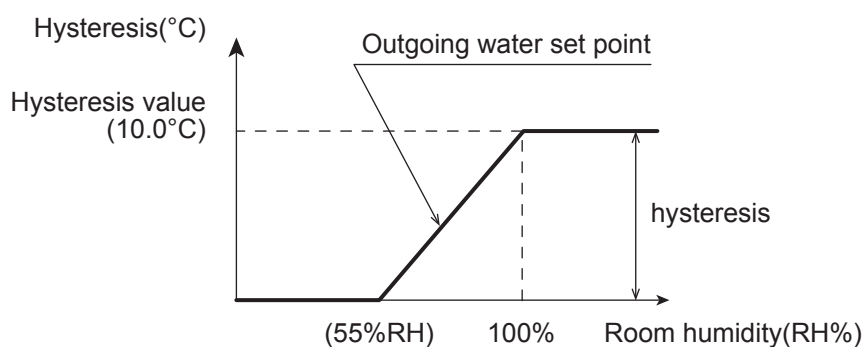

Note: If the HP unit is connected directly to the system, without Buffer tank, the maximum Room humidity compensation has effect on the Outgoing water temperature from the HP unit. If the HP unit is connected to the Buffer tank and the low temperature Zone with a 3way mixing valve is enabled, the maximum Room humidity compensation has effect on the Outgoing water temperature from mixing valve.

Parameters

Level	Parameter		Function description	Display & Input value				Remarks
	Group	Code		Default	min.	Max.	Unit	
I	44	10	Compensation for room humidity 0=disable 1=enable	1	0	1	-	
I	44	11	Room relative humidity value to start increasing Outgoing water temperature set point	55	0	100	1%	
I	44	12	Maximum Outgoing temperature hysteresis corresponding to 100% relative humidity	10.0	0.5	20.0	0.5°C	

7. Unit Management

7.5.13 Space Heating management

The System controller uses the “zone of greatest demand” strategy for calculating the Outgoing water temperature required from the HP unit (and/or EHS as Electric heater or Boiler).

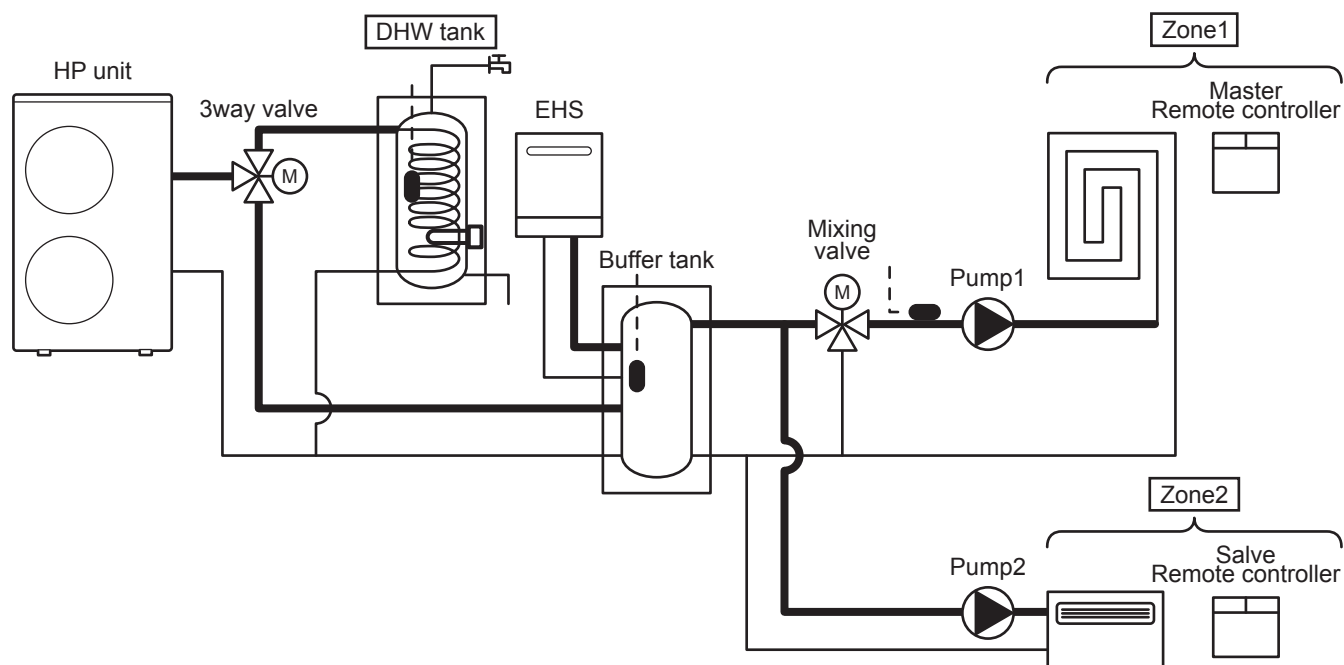

The System controller recognizes 3 zones (Zone1, Zone2, and DHW tank)

Zone1: The mixed or direct Heating loop controlled by the Master Remote controller. Using the Master Remote controller, it is possible to turn the HP unit ON/OFF, toggle between Heating and Cooling, set the Room air temperature, set the Room humidity, and set the Time band for Zone1 and Zone2.

Zone2: The direct Heating loop controlled by the Slave Remote controller. Using the Slave Remote controller, it is possible to turn the HP unit ON/OFF, and set the Room air temperature.

*The time and date setting and time band setting are carried out using the Master Remote controller.

DHW tank: The DHW tank loading loop (cylinder coil). The Master Remote controller is used to specify the DHW related settings.

Each Zone can generate a demand to the HP unit (and/or EHS as Electric heater or Boiler) for a particular supply water temperature

Zone1: The Outgoing water set point required by the “Zone1” Heating loop or Cooling loop

Zone2: The Outgoing water set point required by the “Zone2” Heating loop or Cooling loop

DHW tank: The Outgoing water set point required by the DHW loop.

7. Unit Management

Outgoing water temp control by HP unit

HP unit operates in order to reach the set point of Outgoing water temperature or Tank temperature (DHW tank or Buffer tank).

Set point of Outgoing water temperature of Heating/Cooling can be Fixed or Climatic curve. To reach the set point of Tank temperature, the Outgoing temperature shall be set as a Maximum water temperature (75°C) in Heating or Minimum water temperature (7°C) in Cooling mode.

By Dual set point (Par5122, Terminal 22-23), the set point of Zone2 can be applied.

According to each Zone set point, the HP unit or water pump for each Zone can be turned ON/OFF.

Each sensor shall be defined as below, and the HP unit control in main system is as below 1) to 4).

S1= Sensor, Outgoing water temperature (on HP unit)

S2= Sensor, DHW tank temperature

S3= Sensor, Buffer tank temperature

S4= Sensor, Mixed water temperature

T1= Sensor, Room air temperature Zone1 (on Master Remote controller)

T2= Sensor, Room air temperature Zone2 (on Slave Remote controller)

1) Zone1 only

In the case of room temp control, Par 4100=0, HP unit can be turned ON/OFF by T1 and set point of Remote controller.

In the case of water temp control, Par4100=1, HP unit operates in order for S1 to reach the set point (Fixed or Climatic curve).

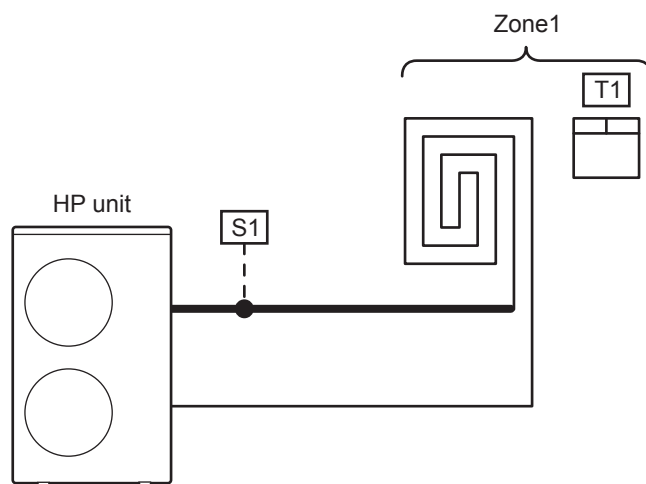

Parameters

Level	Parameter		Function description	Display & Input value				Remarks
	Group	Code		Default	min.	Max.	Unit	
I	41	00	The HP unit turns ON/OFF based on 0=Room set point 1=Water set point	1	0	1	-	

7. Unit Management

2) Zone1 and Zone2

In the case of room temp control, Par4100=0, the HP unit can be turned ON/OFF by T1, T2 and the set point of Remote controller (HP unit is turned OFF if both T1 and T2 reach the set point)

In the case of water temp control, Par4100=1, the HP unit operates in order for S1 to reach the set point (Fixed or Climatic curve)

As for the set point of S1 (Fixed or Climatic curve) at Zone2 ON, if Terminal 22-23 (Dual set point) is OPEN, it will be set point of Zone1. If Terminal 22-23 (Dual set point) is CLOSED, it will be set point of Zone2.

If dual set point is enable (Terminal 22-23 is CLOSED) and both set points of Zone1 and 2 are not reached, the target set point will be the higher set point compared to the set point of Zone1 and Zone2.

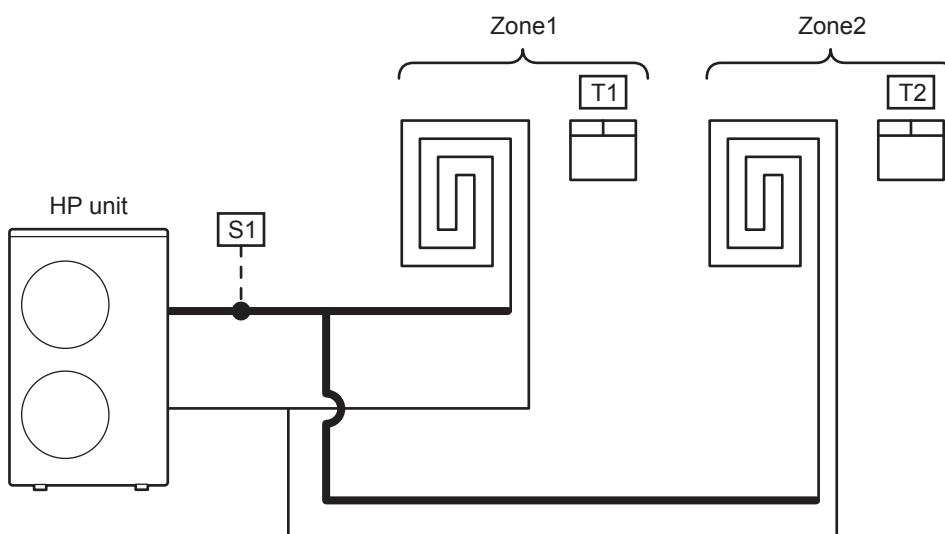

Parameters

Level	Parameter		Function description	Display & Input value				Remarks
	Group	Code		Default	min.	Max.	Unit	
I	41	00	The HP unit turns ON/OFF based on 0=Room set point 1=Water set point	1	0	1	-	
I	51	22	Terminal 22-23 : Dual set point control 0=disable 1=enable	1	0	1	-	

7. Unit Management

3) Zone1, and DHW tank

Heating/Cooling:

In the case of room temp control, Par4100=0, the HP unit can be turned ON/OFF by T1 and the set point of Remote controller.

In the case of water temp control, Par4100=1, the HP unit operates in order for S1 to reach the set point (Fixed or Climatic curve)

DHW tank:

The HP unit operates with maximum water temperature in Heating (75°C) in order for S2 to reach the DHW set point.

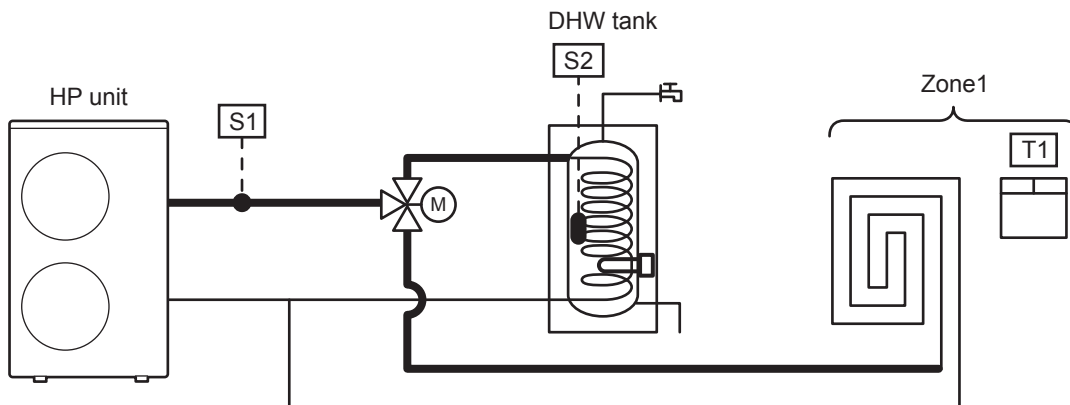

Parameters

Level	Parameter		Function description	Display & Input value				Remarks
	Group	Code		Default	min.	Max.	Unit	
I	41	00	The HP unit turns ON/OFF based on 0=Room set point 1=Water set point	1	0	1	-	

7. Unit Management

4) Zone1 (Pump1, Mixing valve), Zone2 (Pump2), Buffer tank, DHW tank

Heating/Cooling:

In the case of the Buffer tank temperature probe being enabled (Par5111=1), the HP unit operates with maximum water temperature in Heating (75°C) or minimum water temperature in Cooling (7°C) in order for S3 to reach the Buffer tank set point.

Regarding the Buffer tank set point of S3 in the case of Zone2 being ON. If Terminal 22-23 (Dual set point) is OPEN (and Par5122=0), the higher set point shall be selected for Heating mode and the lower set point shall be selected for Cooling mode by comparison between Buffer tank set point and Zone1 water set point. If Terminal 22-23 is CLOSED, the higher set point shall be selected for Heating mode and the lower set point shall be selected for Cooling mode by comparison between Buffer tank set point, Zone1 water set point, and Zone2 water set point.

In order to guarantee correct operation, Buffer tank set point in Heating mode shall be higher than water set points of Zone1 and Zone2. In Cooling mode, on the other hand, Buffer tank set point shall be lower than water set points of Zone1 and Zone2.

Pump1 shall be turned ON/OFF by T1 of Zone1 and Room set point of the Master Remote controller, and Pump2 shall be turned ON/OFF by T2 of Zone2 and Room set point of the Slave Remote controller.

Mixing valve is controlled in order for S4 to reach the water set point of Zone1 (Fixed or Climatic curve).

DHW:

The HP unit operates with maximum water temperature in Heating (75°C) in order for S2 to reach the DHW set point.

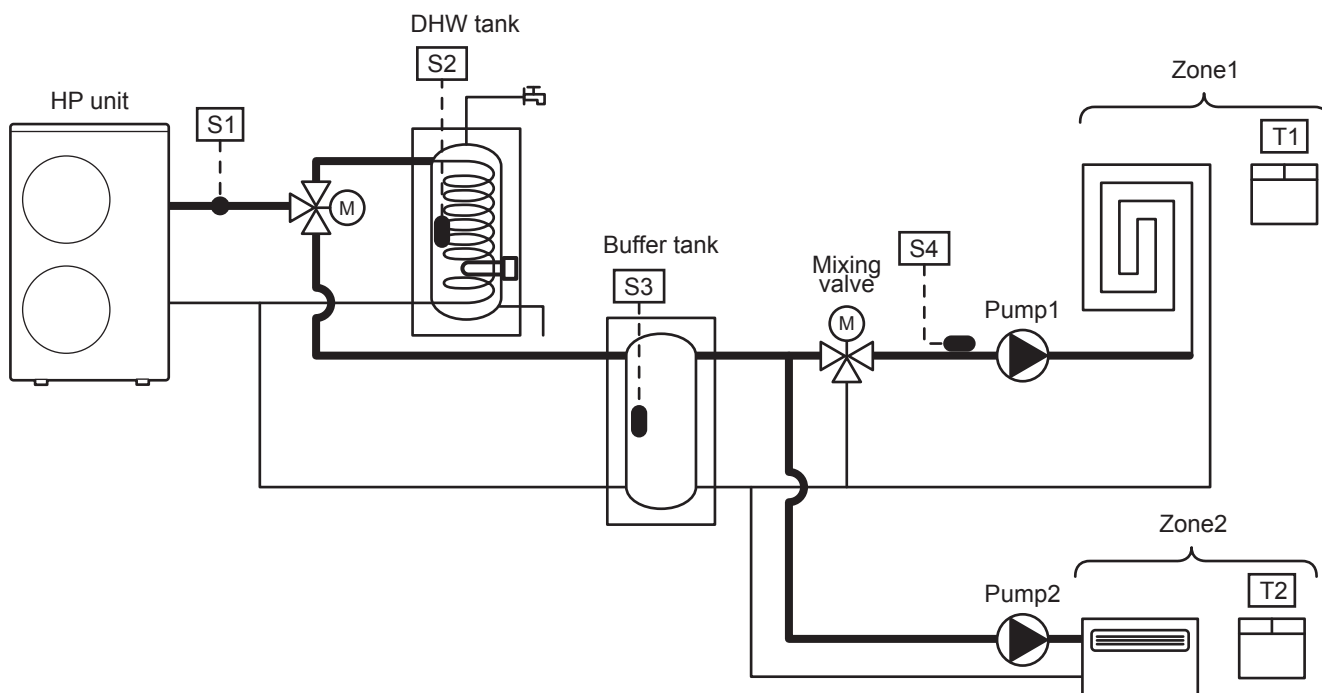

Parameters

Level	Parameter		Function description	Display & Input value				Remarks
	Group	Code		Default	min.	Max.	Unit	
I	41	00	The HP unit turns ON/OFF based on 0=Room set point 1=Water set point	1	0	1	-	To be set to the following combinations Par5111=0 →Par4200=0 or2 Par5111=1 →Par4200=0 or1 or2
I	51	11	Terminal 11-12 : Buffer tank temperature probe 0=disable 1=enable	0	0	1	-	
I	51	22	Terminal 22-23 : Dual set point control 0=disable 1=enable	1	0	1	-	

7. Unit Management

7.5.14 SG Ready

This function is used for SG Ready.

When this mode is enabled, the operating conditions are modified based on inputs received through terminals (Terminal 28-29 and 30-31).

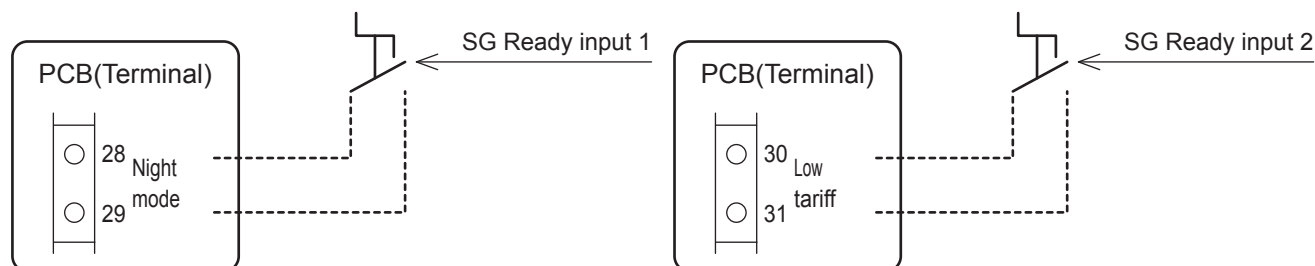

- **Stop (Input 1: close, Input 2 : Open)**

Operation is halted, except for protective functions such as freeze prevention.

- **Normal operation (Input 1: Open, Input 2 : Open)**

Performs normal operations.

- **Recommended Operation (Input 1: Open, Input 2 : Close)**

For heating operation, the value of Parameter 5302 (increased heating temperature at Recommended Operation) is added to the set temperature for normal operation. For cooling operation, the value of Parameter 5303 (decreased cooling temperature at Recommended Operation) is subtracted from the set temperature for normal operation. In the case of DHW operation, the value of Parameter 5304 (DHW increased temperature at Recommended Operation) is added to the set temperature for operation.

When the set water temperature is reached, compressor is halted

Heating : Outgoing water temp. \geq Water set point + Para5302 (Heating temperature added at Recommended Operation)

Cooling : Outgoing water temp. \leq Water set point - Para5303 (Cooling temperature reduced at Recommended Operation)

DHW : Outgoing water temp. \geq Water set point + Para5304 (DHW temperature added at Recommended Operation)

Compressor OFF→ON control

Heating : Outgoing water temp. \leq Water set point + Para5302(Heating temperature added at Recommended Operation) - Para5305 (Heating hysteresis at Recommended Operation)

Cooling : Outgoing water temp. \geq Water set point - Para5303 (Cooling temperature reduced at Recommended Operation) - Para5306 (Cooling hysteresis at Recommended Operation)

DHW : Outgoing water temp. \leq Water set point + Para5304(DHW temperature added at Recommended Operation) - Para5307 (DHW hysteresis at Recommended Operation)

7. Unit Management

• Forced Operation(Input 1: Close, Input 2 : Close)

For heating operation, the value of Parameter 5308 (increased heating temperature at Forced Operation) is added to the set temperature for normal operation. For cooling operation, the value of Parameter 5309 (decreased cooling temperature at Forced Operation) is subtracted from the set temperature for normal operation. In the case of DHW operation, the value of Parameter 5310 (DHW increased temperature at Forced Operation) is added to the set temperature for operation.

When the set water temperature is reached, compressor is halted

Heating : Outgoing water temp. \geq Water set point + Para5308 (Heating temperature added at Forced Operation)

Cooling : Outgoing water temp. \leq Water set point - Para5309 (Cooling temperature reduced at Forced Operation)

DHW : Outgoing water temp. \geq Water set point + Para5310 (DHW temperature added at Forced Operation)

Compressor OFF→ON control

Heating : Outgoing water temp. \leq Water set point + Para5308(Heating temperature added at Forced Operation) - Para5311(Heating hysteresis at Forced Operation)

Cooling : Outgoing water temp. \geq Water set point - Para5309 (Cooling temperature reduced at Forced Operation) - Para5312(Cooling hysteresis at Forced Operation)

DHW : Outgoing water temp. \leq Water set point + Para5310(DHW temperature added at Forced Operation) - Para5313(DHW hysteresis at Forced Operation)

Parameters

Level	Parameter		Function description	Display & Input value				Remarks
	Group	Code		Default	min.	Max.	Unit	
I	53	01	SG Ready 0=disable 1=enable	0	0	1	-	
I	53	02	Heating temperature added at Recommended Operation	3.0	0.0	52.0	0.5°C	
I	53	03	Cooling temperature reduced at Recommended Operation	3.0	0.0	16.0	0.5°C	
I	53	04	DHW temperature added at Recommended Operation	3.0	0.0	52.0	0.5°C	
I	53	05	Heating hysteresis at Recommended Operation	8.0	4.0	10.0	0.5°C	
I	53	06	Cooling hysteresis at Recommended Operation	8.0	4.0	10.0	0.5°C	
I	53	07	DHW hysteresis at Recommended Operation	8.0	4.0	10.0	0.5°C	
I	53	08	Heating temperature added at Forced Operation	5.0	0.0	52.0	0.5°C	
I	53	09	Cooling temperature reduced at Forced Operation	5.0	0.0	16.0	0.5°C	
I	53	10	DHW temperature added at Forced Operation	5.0	0.0	52.0	0.5°C	
I	53	11	Heating hysteresis at Forced Operation	8.0	4.0	10.0	0.5°C	
I	53	12	Cooling hysteresis at Forced Operation	8.0	4.0	10.0	0.5°C	
I	53	13	DHW hysteresis at Forced Operation	8.0	4.0	10.0	0.5°C	

8. Domestic Hot Water Production

8.1 DHW 3way valve management

The DHW 3way valve is used in systems where DHW needs to be stored in the DHW tank. It is used switch the flow of water between the system and the DHW tank loop.

The DHW tank temperature could be detected with a probe.

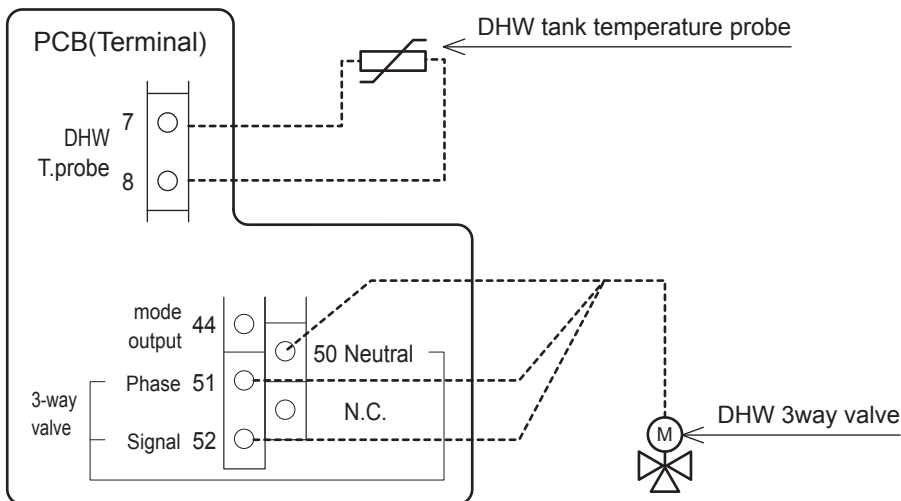
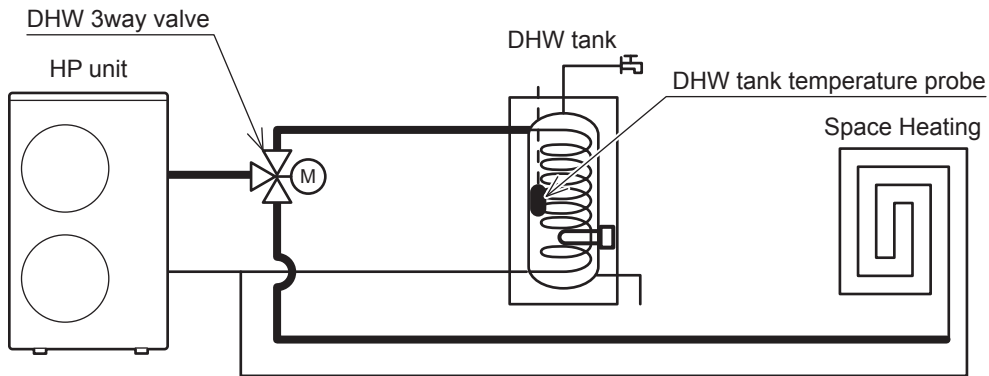

Parameters

Level	Parameter		Function description	Display & Input value				Remarks
	Group	Code		Default	min.	Max.	Unit	
I	51	07	Terminal 7-8 : DHW tank temperature probe 0=disable 1=enable	0	0	1	-	
I	51	50	Terminal 50-51-52 : DHW 3way valve 1=enable	1	1	1	-	

8. Domestic Hot Water Production

8.1.1 Max time for DHW request

In case of a simultaneous demand, a parameter with which the priority between DHW and System is specified is available.

The switching from DHW to the System after the first startup will be based on reaching of DHW set point or by Par3121 (60min), and the switching from the System to the DHW will be based on Par3122 (15min).

Parameters

Level	Parameter		Function description	Display & Input value				Remarks
	Group	Code		Default	min.	Max.	Unit	
I	31	01	DHW production priority setting 0=DHW is unavailable 1=DHW is available, and priority DHW over space Heating 2=DHW is available, and priority space Heating over DHW	0	0	2	-	
I	31	21	Max. time for DHW request	60	0	900	1min	
I	31	22	Min. time for space Heating/Cooling	15	0	900	1min	

8.1.2 DHW 3way valve change over time

The DHW 3way valve will change over according to the function described in the following graph (from system to DHW and vice-versa).

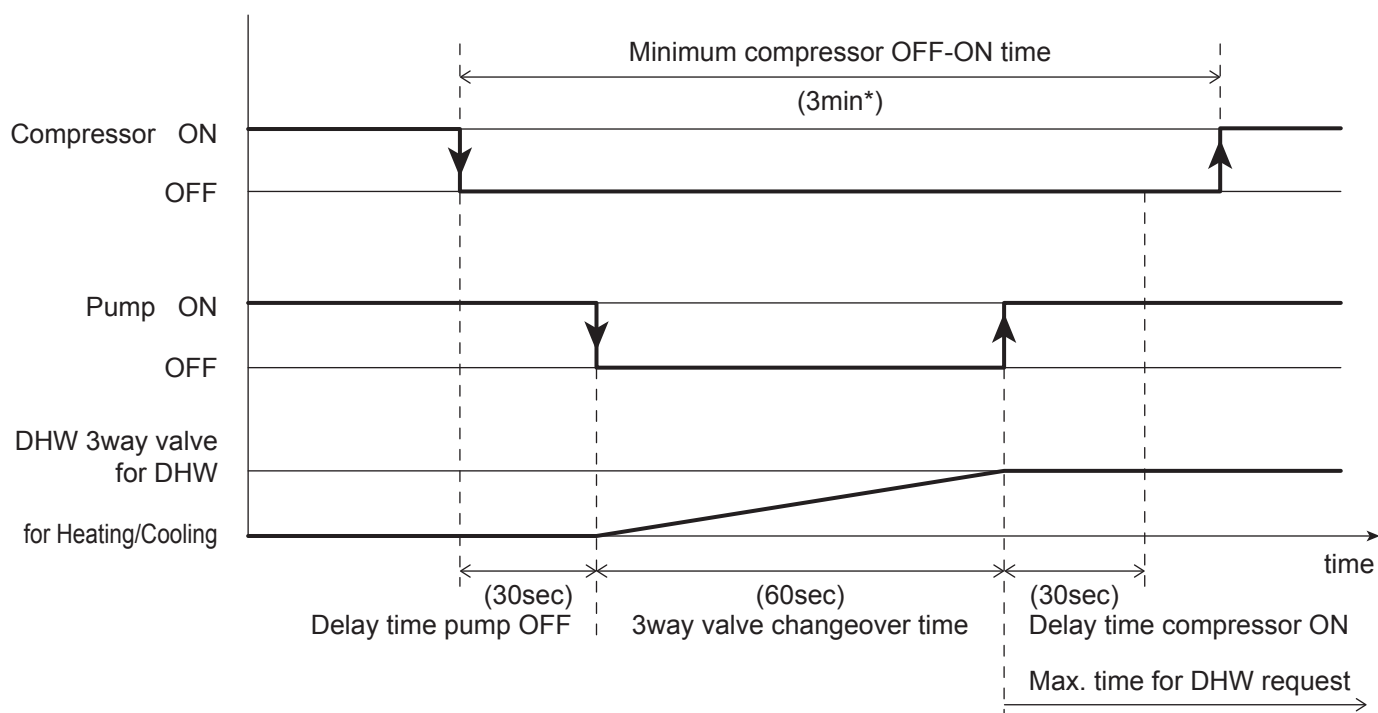

*Minimum compressor OFF-ON time (3min) is a fixed value. The interval time is necessary for refrigerant cycle safety, it cannot be changed.

Note: If the Defrost cycle is required during DHW production, the 3way valve will change over to the system, to avoid Cooling the DHW tank due to the cycle being reversed.

Parameters

Level	Parameter		Function description	Display & Input value				Remarks
	Group	Code		Default	min.	Max.	Unit	
I	41	22	Delay time pump OFF from compressor OFF	30	0	900	1sec	
I	41	23	Delay time compressor ON from pump ON	30	0	900	1sec	
I	45	11	3way valve change over time	60	1	900	1sec	

8. Domestic Hot Water Production

8.2 DHW production mode

DHW production can be activated/deactivated by:

- Pressing the DHW button on the Remote controller
- DHW remote contact
- Pressing the Timer for DHW button on the Remote controller

The heat pump can heat only the DHW tank when hot or cold water is not needed for space Heating/Cooling. Setting Par3101 to completely disable the DHW function to avoid the selection by the DHW button. With this setting the HP unit is able to work only for the Heating/Cooling system.

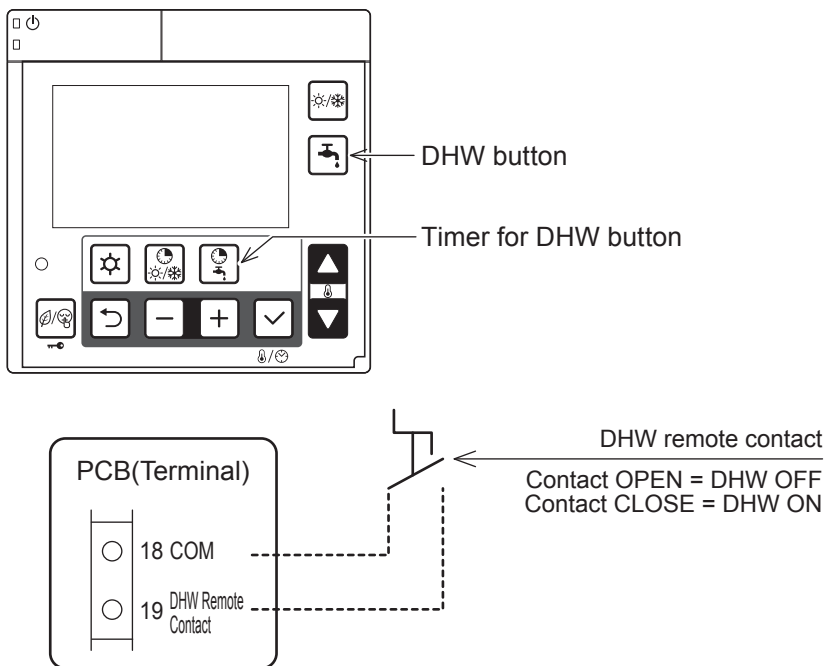

Parameters

Level	Parameter		Function description	Display & Input value				Remarks
	Group	Code		Default	min.	Max.	Unit	
I	31	01	DHW production priority setting 0=DHW is unavailable 1=DHW is available, and priority DHW over space Heating 2=DHW is available, and priority space Heating over DHW	0	0	2	-	In order to use DHW function, it is necessary to set Par3101=1 or2 Par5107=1
I	51	07	Terminal 7-8 : DHW tank temperature probe 0=disable 1=enable	0	0	1	-	
I	51	19	Terminal 19-18 : DHW remote contact 0=disable (Remote controller only) 1=enable	0	0	1	-	

8. Domestic Hot Water Production

The following set points are used for temperature control

Par3111: DHW Comfort set point (typically used in the daytime, when time bands have been set)

Par3112: DHW Economy set point (typically used at night, when time bands have been set)

Par3114: DHW Over boost set point (this value allows the DHW tank to be heated to a temperature above the set point, either Comfort or Economy)

Parameters

Level	Parameter		Function description	Display & Input value				Remarks
	Group	Code		Default	min.	Max.	Unit	
I	31	11	DHW Comfort set temperature	50.0	40.0	75.0	0.5°C	
I	31	12	DHW Economy set temperature	40.0	30.0	65.0	0.5°C	
I	31	13	DHW set point hysteresis	3.0	1.0	10.0	0.5°C	
I	31	14	DHW Over boost mode set point	60.0	50.0	90.0	0.5°C	
I	31	15	DHW Over boost mode set point hysteresis	5.0	0.5	10.0	0.5°C	

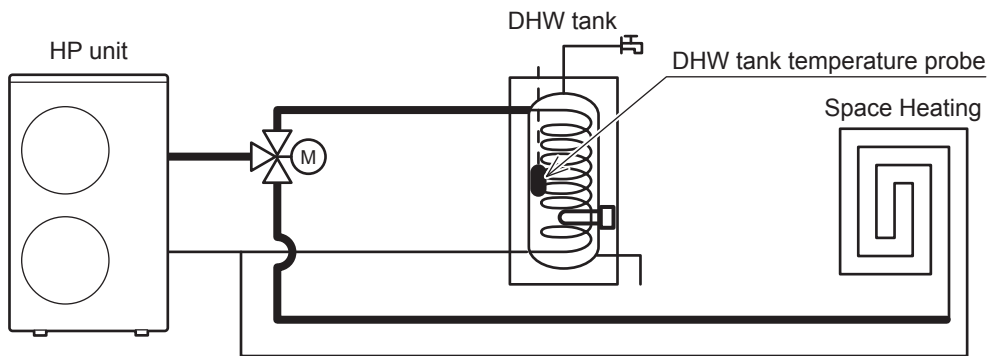

The DHW can be heated as following configuration by setting Par3102.

Par3102=0: Fill DHW tank with HP unit + heater in replacement mode (in this case the HP unit will be used while this is able to heat the DHW tank, then operation will continue using the immersed heater).

Par3102=1: Fill DHW tank with HP unit only

Par3102=2: Fill DHW tank with DHW Electric heater only

Parameters

Level	Parameter		Function description	Display & Input value				Remarks
	Group	Code		Default	min.	Max.	Unit	
I	31	02	Type of configuration to heat the DHW 0=Heat pump + Heater 1=Heat pump only 2=Heater only	1	0	2	-	
I	51	46	Terminal 46 : DHW Electric heater or Backup heater 0=DHW Electric heater 1=Backup heater	0	0	1	-	

8. Domestic Hot Water Production

8.2.1 Heat pump only

The HP unit is activated to produce DHW, if the DHW tank temperature falls below the value set for parameter “Economy DHW set point – DHW hysteresis” or “Comfort DHW set point – DHW hysteresis”.

HP unit stops DHW production:

- When the DHW tank temperature reached to DHW set point.
- When Outgoing water temperature reaches to the maximum set temperature, according to the operating limits of HP unit.

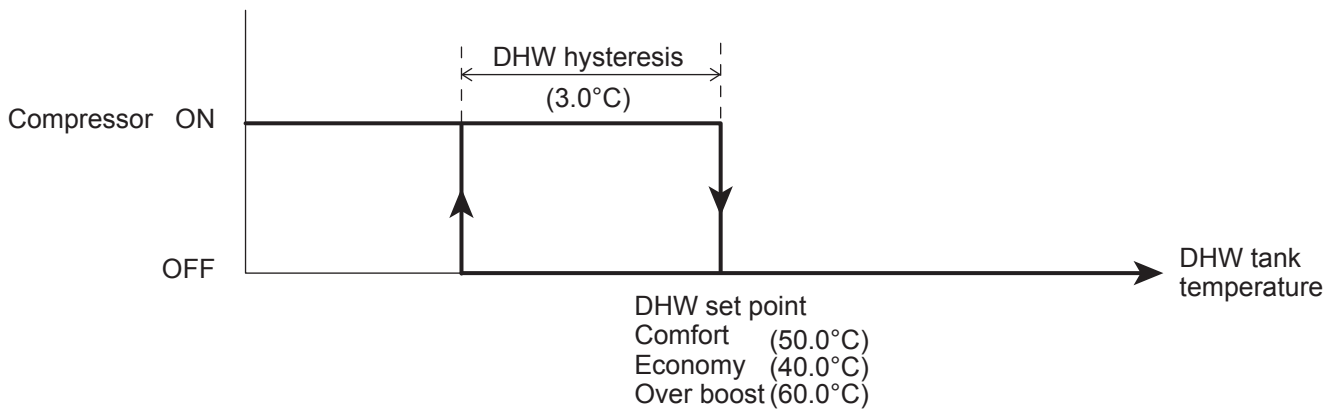

Parameters

Level	Parameter		Function description	Display & Input value				Remarks
	Group	Code		Default	min.	Max.	Unit	
I	31	02	Type of configuration to heat the DHW 0=Heat pump + Heater 1=Heat pump only 2=Heater only	1	0	2	-	
I	31	11	DHW Comfort set temperature	50.0	40.0	75.0	0.5°C	
I	31	12	DHW Economy set temperature	40.0	30.0	65.0	0.5°C	
I	31	13	DHW set point hysteresis	3.0	1.0	10.0	0.5°C	
I	31	14	DHW Over boost set point	60.0	50.0	90.0	0.5°C	
I	31	15	DHW Over boost set point hysteresis	5.0	0.5	10.0	0.5°C	

8. Domestic Hot Water Production

Note1: Whenever HP unit stops producing DHW, it becomes available again to produce for the Heating/Cooling system.

Note2: To prevent the HP unit operating in DHW mode for too long, the maximum DHW production time must be set using Par3121 (60min), after which the unit will once again be available for space Heating/Cooling. The unit will be available for space Heating/Cooling for a minimum time set using Par3122 (15min), even if there is no demand from the system.

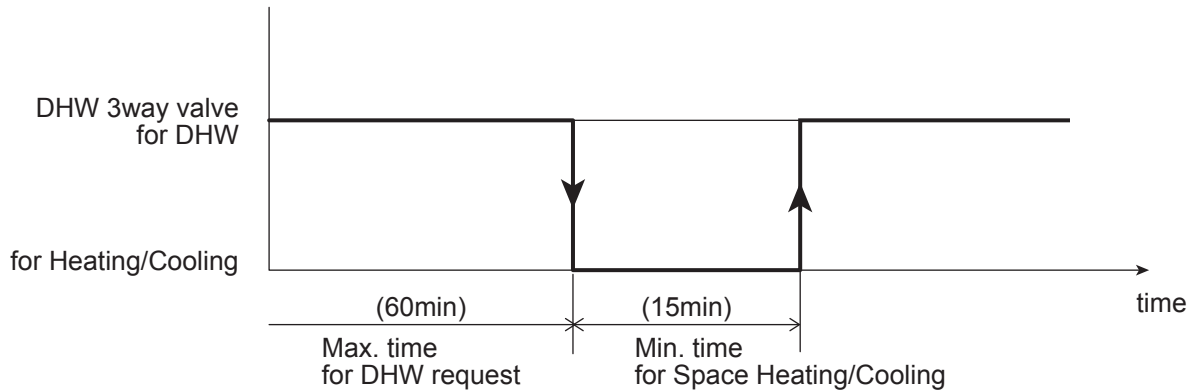

Parameters

Level	Parameter		Function description	Display & Input value				Remarks
	Group	Code		Default	min.	Max.	Unit	
I	31	21	Max. time for DHW request	60	0	900	1min	
I	31	22	Min. time for space Heating/Cooling	15	0	900	1min	

8. Domestic Hot Water Production

8.2.2 DHW Electric heater only

In this configuration, the DHW tank will only be heated using the DHW Electric heater.

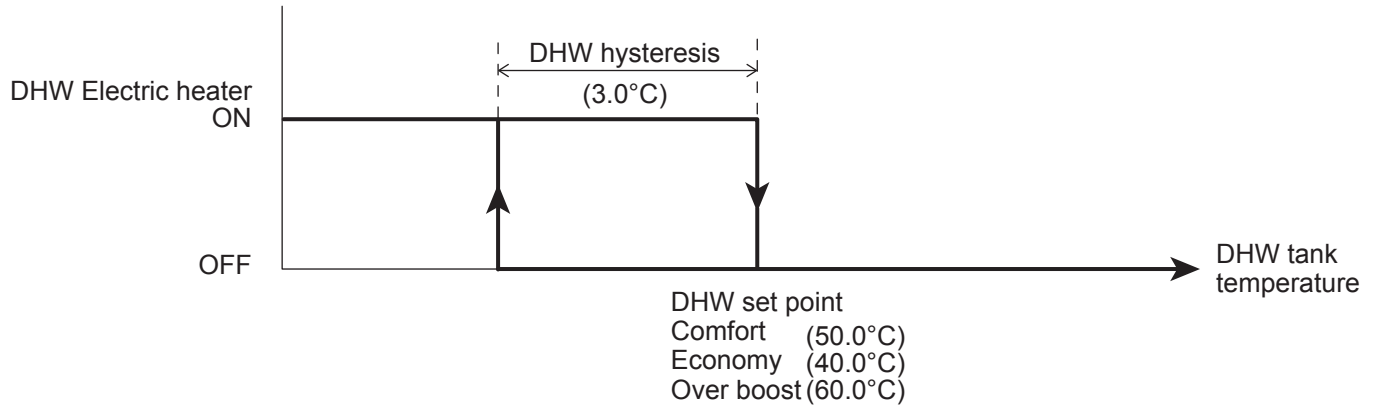

If the Par3102=2 (Heater only), the heat pump produces hot or cool water for the system and the hot water will be heated by the electrical heater only.

Parameters

Level	Parameter		Function description	Display & Input value				Remarks
	Group	Code		Default	min.	Max.	Unit	
I	31	02	Type of configuration to heat the DHW 0=Heat pump + Heater 1=Heat pump only 2=Heater only	1	0	2	-	
I	31	11	DHW Comfort set temperature	50.0	40.0	75.0	0.5°C	
I	31	12	DHW Economy set temperature	40.0	30.0	65.0	0.5°C	
I	31	13	DHW set point hysteresis	3.0	1.0	10.0	0.5°C	
I	31	14	DHW Over boost set point	60.0	50.0	90.0	0.5°C	
I	31	15	DHW Over boost set point hysteresis	5.0	0.5	10.0	0.5°C	

8. Domestic Hot Water Production

Digital Output “Electric heater”

Note: Terminal46 (Electric heater) digital output can be set by Par5146, for the DHW Electric heater output, or for the Backup heater.

If the digital output is “DHW Electric heater” the digital output follows the logic explained “DHW heater only”, “Heat pump + Heater” and “Legionella prevention function”.

If the digital output is “Backup heater” the digital output follows the logic explained “Backup heater”.

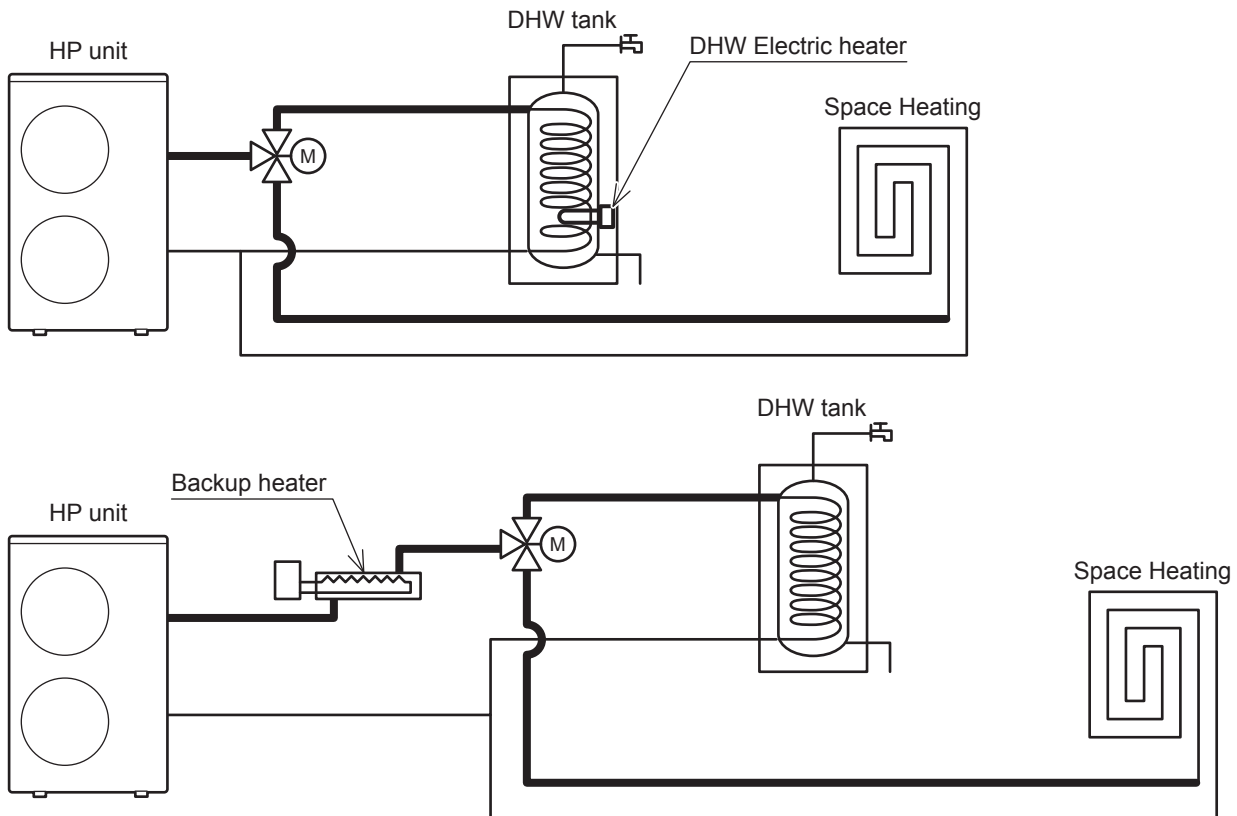

Parameters

Level	Parameter		Function description	Display & Input value				Remarks
	Group	Code		Default	min.	Max.	Unit	
I	51	46	Terminal 46 : DHW Electric heater or Backup heater 0=DHW Electric heater 1=Backup heater	0	0	1	-	

8. Domestic Hot Water Production

8.2.3 Heat pump + DHW heater

The HP unit will operate as described in paragraph “Heat pump only”, with the following differences A) and B).

A) DHW tank temperature reached set point (Comfort or Economy)

The DHW heater will start with a fixed delay of 30 sec, aiming to reach the Over boost set point. Once having reached this set point, it will start again at “Over boost set point – Over boost hysteresis” and will stop again at “Over boost set point”

If the DHW tank keeps cooling down, when reaching DHW Comfort or Economy set point, according to the function described in the following graph:

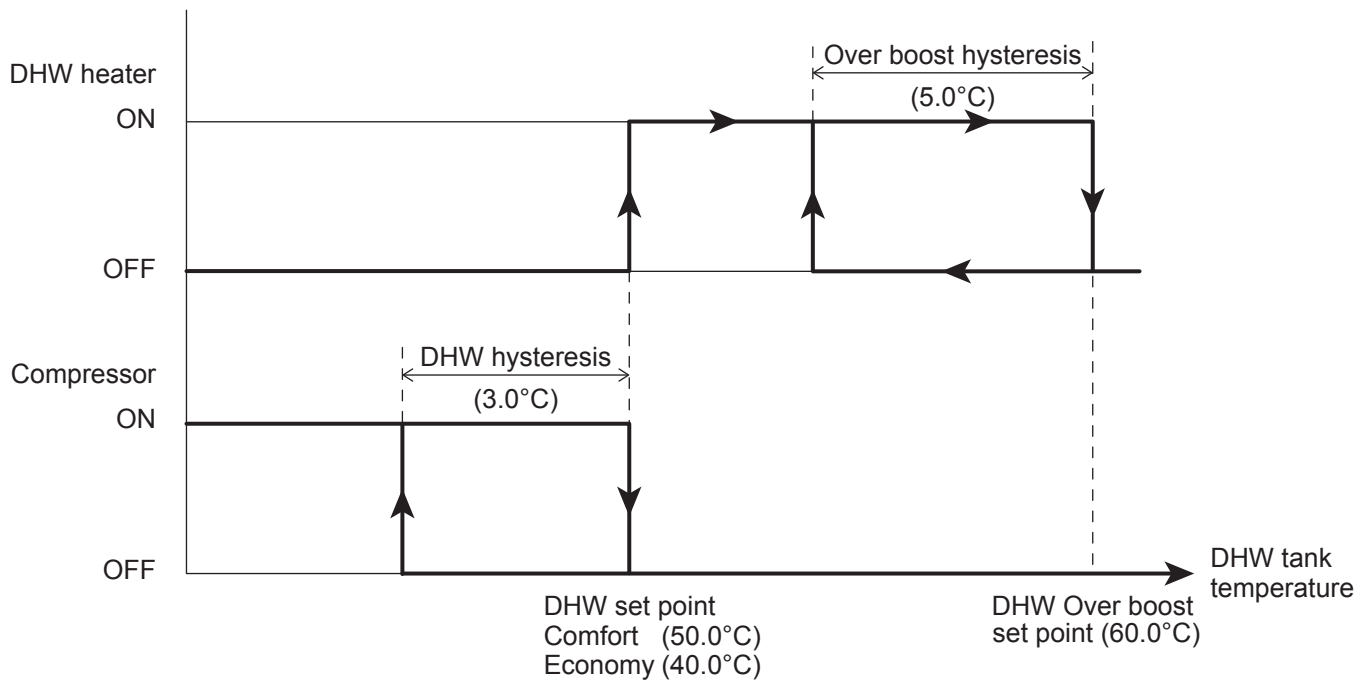

The DHW set point is reached (Comfort or Economy) using the compressor, the Over boost set point will be achieved with the DHW heater only and the HP unit will change over to the system.

Parameters

Level	Parameter		Function description	Display & Input value				Remarks
	Group	Code		Default	min.	Max.	Unit	
I	31	02	Type of configuration to heat the DHW 0=Heat pump + Heater 1=Heat pump only 2=Heater only	1	0	2	-	
I	31	11	DHW Comfort set temperature	50.0	40.0	75.0	0.5°C	
I	31	12	DHW Economy set temperature	40.0	30.0	65.0	0.5°C	
I	31	13	DHW set point hysteresis	3.0	1.0	10.0	0.5°C	
I	31	14	DHW Over boost mode set point	60.0	50.0	90.0	0.5°C	
I	31	15	DHW Over boost mode set point hysteresis	5.0	0.5	10.0	0.5°C	

8. Domestic Hot Water Production

Conditions to be available DHW heaters “Always enabled” or “depends on Outdoor air temperature” shall be selected by Par3132.

In case of “depends on Outdoor air temperature”, the Outdoor air temperature which turns ON DHW heaters shall be set by Par3133.

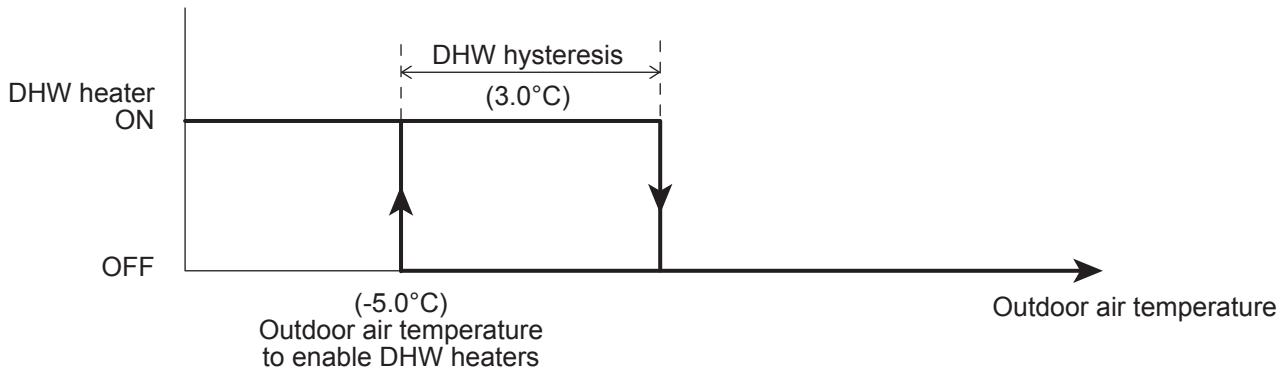

Parameters

Level	Parameter		Function description	Display & Input value				Remarks
	Group	Code		Default	min.	Max.	Unit	
I	31	32	Conditions to be available DHW heaters 0=always enabled 1=depends on Outdoor air temperature	1	0	1	-	
I	31	33	Outdoor air temperature to enable DHW heaters	-5.0	-20.0	20.0	0.5°C	
I	31	34	Outdoor air temperature hysteresis to disable DHW heaters	5.0	0.5	10.0	0.5°C	

Digital Output “Electric heater”

Note1: Terminal46 (Electric heater) digital output can be set by Par5146, for the DHW Electric heater output, or for the Backup heater.

If the digital output is “DHW Electric heater” the digital output follows the logic explained “DHW heater only”, “Heat pump + Heater” and “Legionella prevention function”.

If the digital output is “Backup heater” the digital output follows the logic explained “Backup heater”

Note2: If “Backup heater” is enabled as 1, 2 or 3 by Par4600, the “DHW Over boost set point” will not be available.

Parameters

Level	Parameter		Function description	Display & Input value				Remarks
	Group	Code		Default	min.	Max.	Unit	
I	46	00	Backup heater type of function 0=disable 1=Replacement mode 2=Emergency mode 3=Supplementary mode	0	0	3	-	Par4600 and Par4700 are synchronized Par4600=1, 2, 3 → Par=4700=0 Par4700=1, 2 → Par4600=0
I	51	46	Terminal 46 : DHW Electric heater or Backup heater 0=DHW Electric heater 1=Backup heater	0	0	1	-	

8. Domestic Hot Water Production

B) HP unit is out of operation range

The compressor will be stopped and the DHW heater will be started, aiming to reach the Over boost set point.

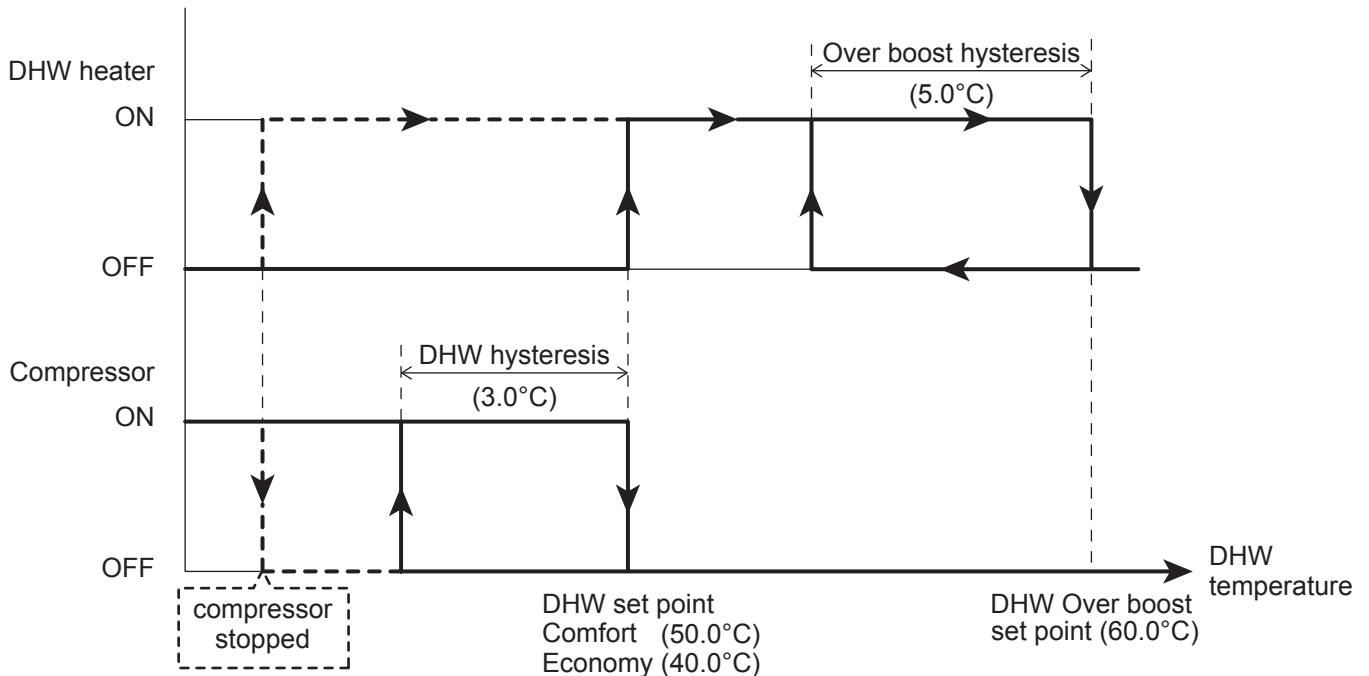

Digital Output “Electric heater”

Note1: Terminal46 (Electric heater) digital output can be set by Par5146, for the DHW Electric heater output, or for the Backup heater.

If the digital output is “DHW Electric heater” the digital output follows the logic explained “DHW heater only”, “Heat pump + Heater” and “Legionella prevention function”.

If the digital output is “Backup heater” the digital output follows the logic explained “Backup heater”

Note2: If “Backup heater” is enabled as 1, 2 or3 by Par4600, the “DHW Over boost set point” will not be available.

Parameters

Level	Parameter		Function description	Display & Input value				Remarks
	Group	Code		Default	min.	Max.	Unit	
I	51	46	Terminal 46 : DHW Electric heater or Backup heater 0=DHW Electric heater 1=Backup heater	0	0	1	-	

8. Domestic Hot Water Production

8.2.4 Legionella prevention function

This function is to sterilize legionella bacteria by heating and maintaining the specific temperature (65°C or higher) in DHW tank for the specific time (10min).

Regarding the conditions of this function, “States (enable/disable)”, “Operation interval (day of the week)”, and “Start time (start production to anti legionella set point)” shall be set by parameter.

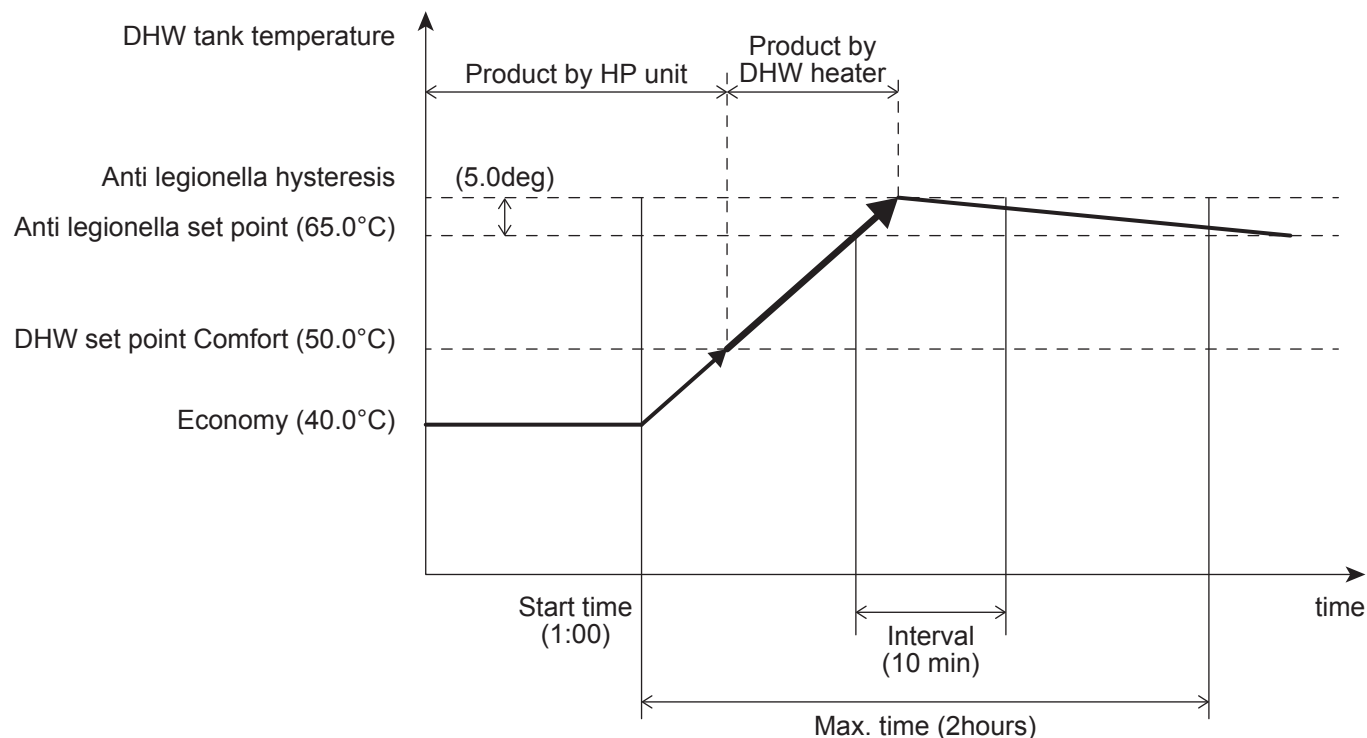

Parameters

Level	Parameter		Function description	Display & Input value				Remarks
	Group	Code		Default	min.	Max.	Unit	
I	31	40	Anti-legionella function 0=disable 1=enable	0	0	1	-	
I	31	41	Anti-legionella operation day of week 0=Mon, 1=Tue, 2=Wed, 3=Thu, 4=Fri, 5=Sat, 6=Sun	0	0	6	-	
I	31	42	Start time of the day at which the DHW should be heated for Anti-legionella	1:00	0:00	23:00	1:00	

Note1: DHW Electric heater will be used in order to reach the specific temperature (65°C or higher) in DHW tank. Therefore, DHW Electric heater shall be available if the anti-legionella function is enabled.

Note2: When the anti-legionella function is enabled (Par3140=1), the Electric heater will also be activated for anti-legionella function even if DHW production is with only heat pump (Par3102=1)

Note3: The anti-legionella function will be finished after the specific time (2hours) has passed from the start of the heating DHW tank even though the temperature in the tank has not completed the function (65°C or higher for 10 min) within the time (2hours).

If this function is not completed in for the specific times repeatedly, the alarm (LC) will be displayed.

8. Domestic Hot Water Production

8.3 Backup heater

The function of Backup heater is to heat DHW tank and Heating system in Replace or Supplementary mode by the HP unit when the Heating capacity of HP unit is decreased by lower Outdoor air temperature and when the HP unit is stopped due to the failure of sensors.

In addition, Backup heater will be turned ON for anti-freezing of water circuit at Start-up of HP unit or during defrost operation.

If the heater is enabled, it must be installed before of the 3way valve as picture below.

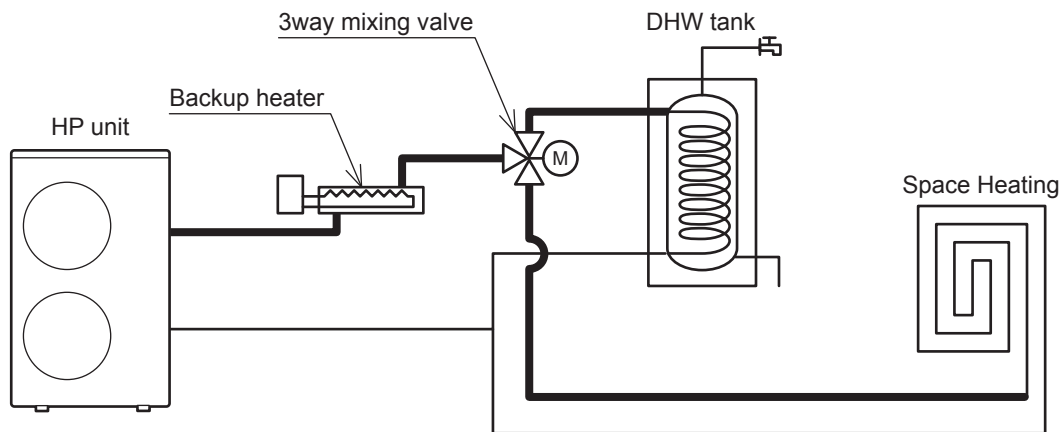

A parameter defines if the Backup heater can be enabled or disabled, and the “Type of function”:

- Heater in Replacement mode
- Emergency mode
- Heater in Supplementary mode

Digital Output “Electric heater”

Note1: Terminal46 (Electric heater) digital output can be set by Par5146, for the DHW Electric heater output, or for the Backup heater.

If the digital output is “DHW Electric heater” the digital output follows the logic explained “DHW heater only”, “Heat pump + Heater” and “Legionella prevention function”.

If the digital output is “Backup heater” the digital output follows the logic explained “Backup heater”

Note2: If “Backup heater” is enabled as 1, 2 or 3 by Par4600, the “DHW Over boost set point” will not be available.

Parameters

Level	Parameter		Function description	Display & Input value				Remarks
	Group	Code		Default	min.	Max.	Unit	
I	46	00	Backup heater type of function 0=disable 1=Replacement mode 2=Emergency mode 3=Supplementary mode	0	0	3	-	Par4600 and Par4700 are synchronized Par4600=1, 2, 3 → Par=4700=0 Par4700=1, 2 →Par4600=0
I	51	46	Terminal 46 : DHW Electric heater or Backup heater 0=DHW Electric heater 1=Backup heater	0	0	1	-	

8. Domestic Hot Water Production

8.3.1 Backup heater in Replacement mode

The Backup heater is activated for space Heating or DHW (in the latter case, only if no dedicated DHW tank heater is fitted) to replace the compressor, if the compressor is unable to meet demand as it has shut down for one of the following reasons:

- HP unit stopped (according of operating limits)
- Probe faults (see lists below)

When probe faults occurred, The Backup heater is activated for;

Error code/name	Heating	DHW
P3 Refrigerant High Pressure switch Failure	ON	ON
FU Refrigerant High Pressure switch Operation	ON	ON
A7 Sensor (temp. Defrost)	ON	ON
A8 Sensor (temp. Discharge)	ON	ON
E5 Sensor (temp. Return water)	ON	ON
L1 Sensor (temp. DHW tank)	ON	OFF
L3 Sensor (temp. Buffer tank)	OFF	ON
L4 Sensor (temp. Mixed water)	OFF	ON
L5 Sensor (Humidity)	OFF	ON
L8 Sensor (temp. Room air, Master Remote controller)	OFF	ON
L9 Sensor (temp. Room air, Slave Remote controller)	OFF	ON

For heating system water production, the Backup heater will be controlled using the same control as the compressor in Heating mode.

For DHW production, aiming to reach the “Comfort or Economy” set point.

However the manual mode can also be selected, setting Par4600=2 (Emergency), the water will only be heated using the Backup heater, disabling compressor operation. This mode is typically used in the event of compressor faults.

The Backup heater will be activated as described below:

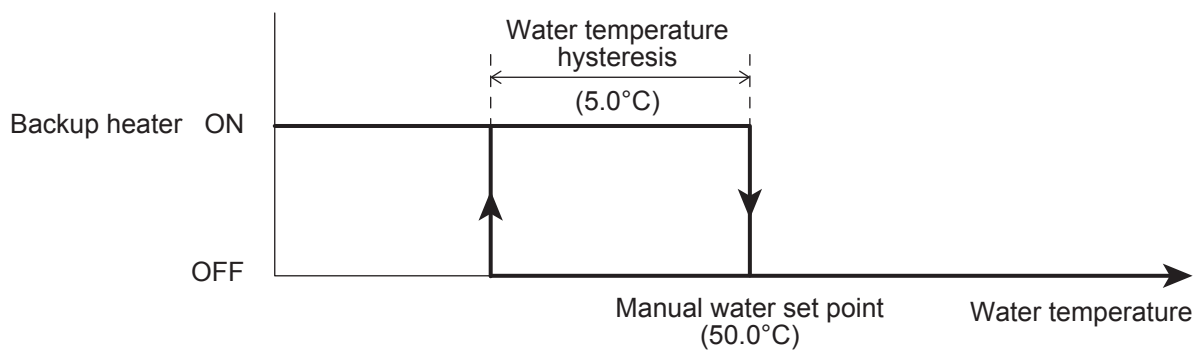

8. Domestic Hot Water Production

Note1: If “Frost protection on Room air temperature” is activated, the top priority is the set point of Frost protection (Par4303=35°C) than that of Emergency mode (Par4601=50°C).

Note2: The Backup heater will be available for the System during “Min. time for space Heating/Cooling” after the “Max. time for DHW request” or if it reaches the DHW water set point.

Parameters

Level	Parameter		Function description	Display & Input value				Remarks
	Group	Code		Default	min.	Max.	Unit	
I	46	00	Backup heater type of function 0=disable 1=Replacement mode 2=Emergency mode 3=Supplementary mode	0	0	3	-	Par4600 and Par4700 are synchronized Par4600=1, 2, 3 → Par=4700=0 Par4700=1, 2 → Par4600=0
I	46	01	Manual water set point	50.0	40.0	75.0	0.5°C	
I	46	02	Manual water temperature hysteresis	5.0	0.5	10.0	0.5°C	
I	31	21	Max. time for DHW request	60	0	900	1min	
I	31	22	Min. time for space Heating/Cooling	15	0	900	1min	

8. Domestic Hot Water Production

Must be allowed to define the Outdoor air temperature below which the space heating or DHW will be heated by Backup heater according the explanation above. Parameter to define whether the Backup heater is “always enabled” or enabled only if the Outdoor air temperature is below the value set in parameter “Outdoor air temperature to enable Backup heater”.

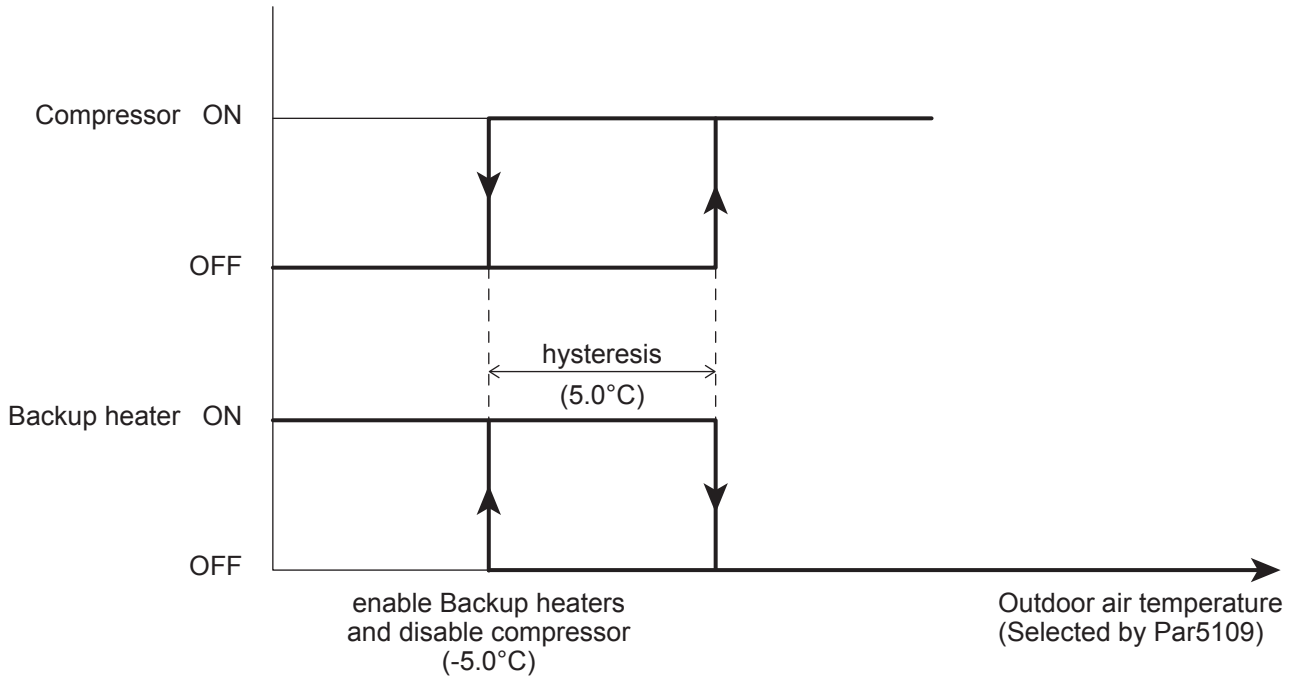

Parameters

Level	Parameter		Function description	Display & Input value				Remarks
	Group	Code		Default	min.	Max.	Unit	
I	46	10	Conditions to be available Backup heaters 0=always enabled 1=depends on Outdoor air temperature	1	0	1	-	
I	46	11	Outdoor air temperature to enable Backup heaters and disable compressor	-5.0	-20.0	20.0	0.5°C	
I	46	12	Outdoor air temperature hysteresis to disable Backup heaters and enable compressor	5.0	0.5	10.0	0.5°C	
I	51	46	Terminal 46 : DHW Electric heater or Backup heater 0=DHW Electric heater 1=Backup heater	0	0	1	-	

Note: If Terminal46 (Electric heater) will be enabled as Backup heater, the “External heat source for space heating” will be not allowed. To guarantee correct operation, the two functions cannot be activated at the same time.

8. Domestic Hot Water Production

8.3.2 Backup heater in Supplementary mode

For space heating, once enabled, the heater will be activated according to the Water temperature, as shown in the following graph.

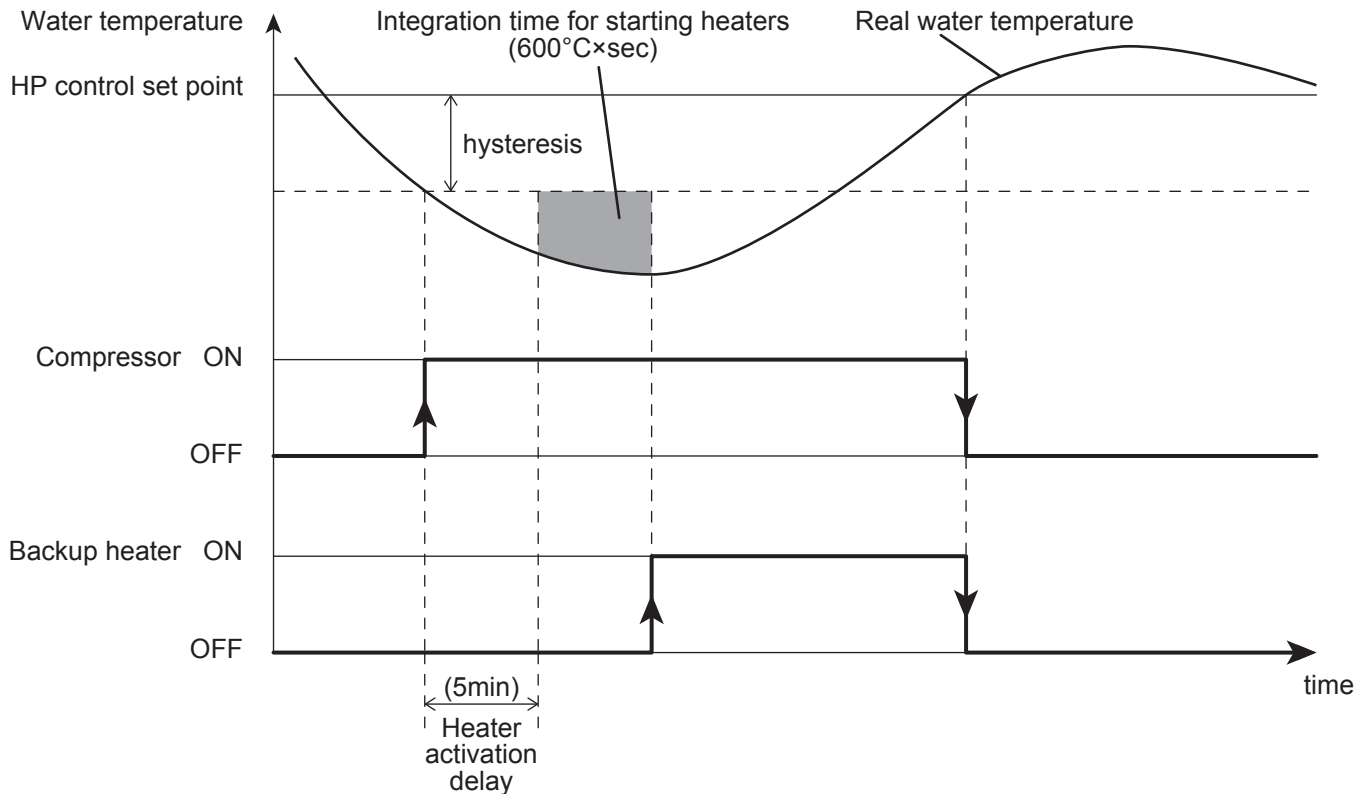

The “HP unit control set point” is equal to the value set for Fixed set point control, or by the value determined by the Climatic curve.

Parameters

Level	Parameter		Function description	Display & Input value				Remarks
	Group	Code		Default	min.	Max.	Unit	
I	46	00	Backup heater type of function 0=disable 1=Replacement mode 2=Emergency mode 3=Supplementary mode	0	0	3	-	Par4600 and Par4700 are synchronized Par4600=1, 2, 3 → Par=4700=0 Par4700=1, 2 → Par4600=0
I	46	04	Heater activation delay time	5	0	900	1min	→ Par4600=0
I	46	05	Integration time for starting heaters	600	0	900	°C×sec	(Outgoing water temp. – Actual temp.) x Integration time calculate every 1sec.

8. Domestic Hot Water Production

Note1: The calculation of the Integration time only begins after the time set for Par4604 (Heater activation delay time) has elapsed. The function is designed to prevent the heater from starting in Supplementary mode, to allow the HP unit time to reach steady operation.

Note2: If the Integration time for starting the heaters is 0, control will be in stages, based on the control set point and the value set for the hysteresis.

Note3: If the HP unit shuts down due to the Outdoor air temperature being above or below its operating limits and due to the Max. water temperature produced based on the Outdoor air temperature, the heater will operate in Replacement mode.

Note4: If Terminal46 (Electric heater) will be enabled as Backup heater, the "External heat source for space heating" will be not allowed. To guarantee correct operation, the two functions cannot be activated at the same time.

Must be allowed to define the Outdoor air temperature below which the space heating will be heated by heater. Set the parameters for Par4610=0 (Backup heater always enabled), or Par4610=1 (depends on Outdoor air temperature).

If Par4610=0, Backup heater is ON based on Par4605 (Integration time for starting heaters) is enable regardless of the Outdoor air temperature.

If Par4610=1, Backup heater can be turned ON only if the both of the following conditions are met
 Par4613 (Outdoor air temperature to enable Backup heater)
 Par4605 (Integration time for starting heaters)

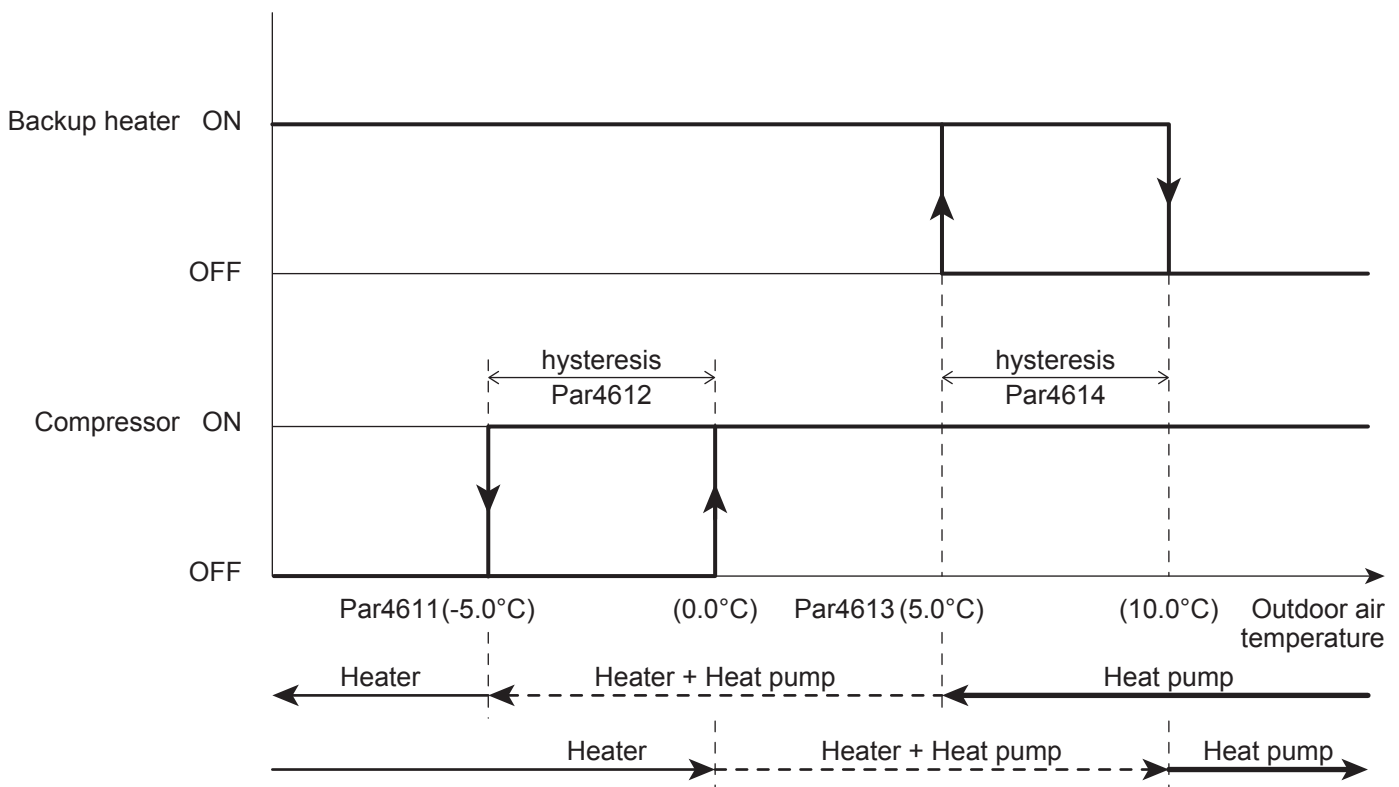

8. Domestic Hot Water Production

Parameters

Level	Parameter		Function description	Display & Input value				Remarks
	Group	Code		Default	min.	Max.	Unit	
I	46	00	Backup heater type of function 0=disable 1=Replacement mode 2=Emergency mode 3=Supplementary mode	0	0	3	-	Par4600 and Par4700 are synchronized Par4600=1, 2, 3 → Par=4700=0 Par4700=1, 2 → Par4600=0
I	46	10	Conditions to be available Backup heaters 0=always enabled 1=depends on <u>Outdoor air temperature</u>	1	0	1	-	
I	46	11	Outdoor air temperature to enable Backup heaters and disable compressor	-5.0	-20.0	20.0	0.5°C	
I	46	12	Outdoor air temperature hysteresis to disable Backup heaters and enable compressor	5.0	0.5	10.0	0.5°C	
I	46	13	Outdoor air temperature to enable Backup heaters (Supplementary mode)	5.0	-20.0	20.0	0.5°C	
I	46	14	Outdoor air temperature hysteresis to disable Backup heaters (Supplementary mode)	5.0	0.5	10.0	0.5°C	

When the Backup heater is selected as Supplementary mode (Par4600=3), two different parameters Par4613 (Outdoor air temperature to enable Backup heater) and Par4614 (Outdoor air temperature hysteresis to disable Backup heater) has to be defined to manage the function correctly.

8. Domestic Hot Water Production

8.3.3 Freeze protection function

The Backup heater can be enabled as “Freeze protection function” and will be operated during the Defrost or Start-up.

The function of Backup heater as “Freeze protection” can be enabled or disabled by Par4620.

Backup heater enabled during Start-up

If the Par4620=1 (enabled during Start-up), the Backup heater will be activated after 30sec. Start-up of the compressor and only if the Outgoing water temperature is lower of the set point by Par4621.

The Backup heater will be turned OFF when it achieves the set point by Par4621 + hysteresis.

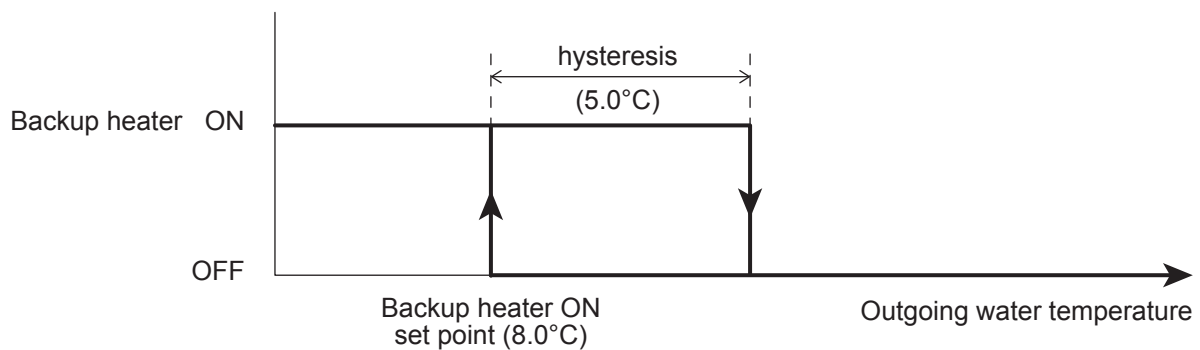

Parameters

Level	Parameter		Function description	Display & Input value				Remarks
	Group	Code		Default	min.	Max.	Unit	
I	46	20	Freeze protection functions 0=disable 1=enabled during Start-up 2=enabled during Defrost 3=enabled during Start-up and Defrost	0	0	3	-	
I	46	21	Outgoing water temperature set point during Start-up	8.0	0.0	60.0	0.5°C	
I	46	22	Hysteresis water temperature set point during Start-up	5.0	0.5	10.0	0.5°C	

8. Domestic Hot Water Production

Backup heater enabled during Defrost

If the Par4620=2 or 3 (enabled during Defrost), the Backup heater shall be turned ON during Defrost operation when Outgoing water temperature is lower than Par4623. Once the water temperature reaches the set point of Par4623 + hysteresis, the Backup heater shall be turned OFF.

In order to operate the Backup heater for Defrost operation with Par4620=2 or 3, it is necessary to set the Par4600=3 (Supplementary mode).

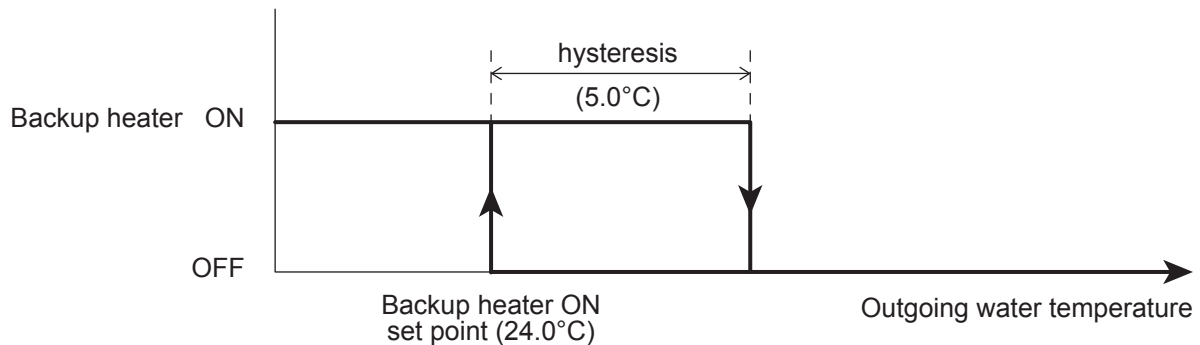

Parameters

Level	Parameter		Function description	Display & Input value				Remarks
	Group	Code		Default	min.	Max.	Unit	
I	46	00	Backup heater type of function 0=disable 1=Replacement mode 2=Emergency mode 3=Supplementary mode	0	0	3	-	Par4600 and Par4700 are synchronize Par4600=1, 2, 3 → Par=4700=0 Par4700=1, 2 → Par4600=0
I	46	20	Freeze protection functions 0=disable 1=enabled during Start-up 2=enabled during Defrost 3=enabled during Start-up and Defrost	0	0	3	-	
I	46	23	Outgoing water temperature set point during Defrost	24.0	10.0	50.0	0.5°C	
I	46	24	Hysteresis water temperature set point during Defrost	5.0	0.5	10.0	0.5°C	

8. Domestic Hot Water Production

8.4 EHS (External heat source)

The function of EHS (External heat source) is to heat the Heating system in Replace or Supplementary mode by HP unit when the heating capacity of HP unit is decreased by lower Outdoor air temperature and when HP unit is stopped due to the failure of sensors.

The EHS function has no impact on the DHW heating mode.

If enabling the EHS, it needs to be connected to Buffer tank as picture below.

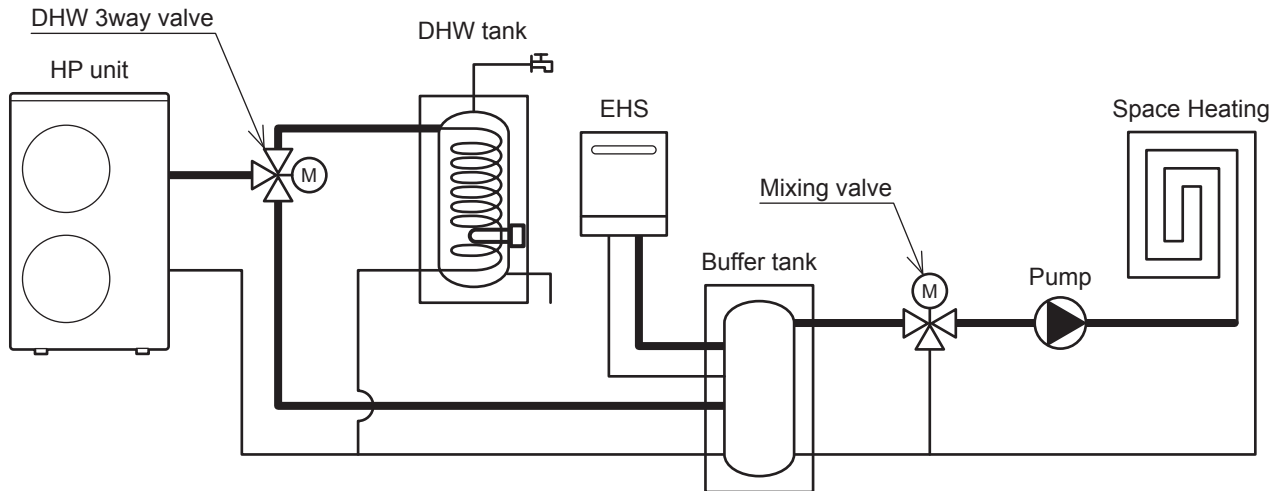

The EHS turns OFF/ON depending of the setting the HP unit.

ON/OFF based on Room air temperature measured by the probe on Remote controller.

ON/OFF based on water set point.

Parameters

Level	Parameter		Function description	Display & Input value				Remarks
	Group	Code		Default	min.	Max.	Unit	
I	47	00	EHS type of function 0=disable 1=Replacement mode 2=Supplementary mode	0	0	2	-	
I	51	41	Terminal 41-42 : EHS (External heat source for space heating) 0=disable 1=enable	0	0	1	-	

8. Domestic Hot Water Production

8.4.1 EHS in Replacement mode

The EHS is activated for Heating to replace the compressor, if the compressor is unable to meet demand as it has shut down for one of the following reasons:

- HP unit stopped (according of operating limits)
- Probe faults (see lists below)

When probe faults occurred, The EHS is activated for;

Error code/name	Heating	DHW
P3 Refrigerant High Pressure switch Failure	ON	ON
FU Refrigerant High Pressure switch Operation	ON	ON
A7 Sensor (temp. Defrost)	ON	ON
A8 Sensor (temp. Discharge)	ON	ON
E5 Sensor (temp. Return water)	ON	ON
L1 Sensor (temp. DHW tank)	ON	OFF
L3 Sensor (temp. Buffer tank)	OFF	ON
L4 Sensor (temp. Mixed water)	OFF	ON
L5 Sensor (Humidity)	OFF	ON
L8 Sensor (temp. Room air, Master Remote controller)	OFF	ON
L9 Sensor (temp. Room air, Slave Remote controller)	OFF	ON

For Heating system water production, the EHS will be controlled using the same control as the compressor in Heating mode.

Must be allowed to define the Outdoor air temperature below which the space Heating will be heated by EHS according the explanation. Parameter to define whether the EHS is "always enabled" or "enabled only if the Outdoor air temperature" is below the value set in parameter "Outdoor air temperature to enable EHS".

When the Outdoor air temperature drops below the "Outdoor air temperature" the HP unit will stop automatically and the permission signal for the EHS becomes active.

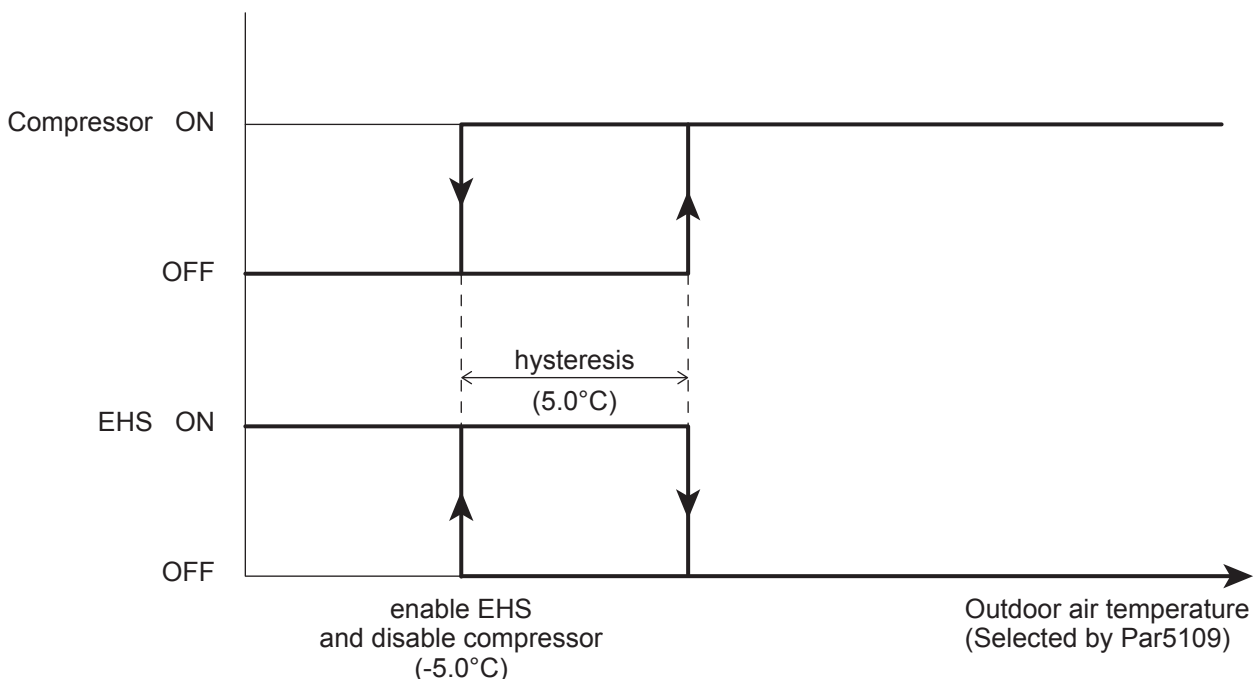

8. Domestic Hot Water Production

Parameters

Level	Parameter		Function description	Display & Input value				Remarks
	Group	Code		Default	min.	Max.	Unit	
I	47	00	EHS type of function 0=disable 1=Replacement mode 2=Supplementary mode	0	0	2	-	Par4600 and Par4700 are synchronize Par4600=1, 2, 3 → Par=4700=0 Par4700=1, 2 → Par4600=0
I	47	01	Conditions to be available EHS 0=always enabled 1=depends on Outdoor air temperature	1	0	1	-	
I	47	02	Outdoor air temperature to enable EHS and disable compressor	-5.0	-20.0	20.0	0.5°C	
I	47	03	Outdoor air temperature hysteresis to disable EHS and enable compressor	5.0	0.5	10.0	0.5°C	
I	51	41	Terminal 41-42 : EHS (External heat source for space heating) 0=disable 1=enable	0	0	1	-	

When the switching of the HP unit ON/OFF is based on water temperature set point, the EHS will be activated according to the water temperature set point based on "Fixed set point" or based on "Climatic curve".

When the switching of the HP unit ON/OFF is based on Room air temperature, the EHS will be activated according to the Room air temperature set point based on "HP unit control".

8. Domestic Hot Water Production

8.4.2 EHS in Supplementary mode

Once space heating is enabled, the EHS will be activated according to the water temperature as shown in the following graph.

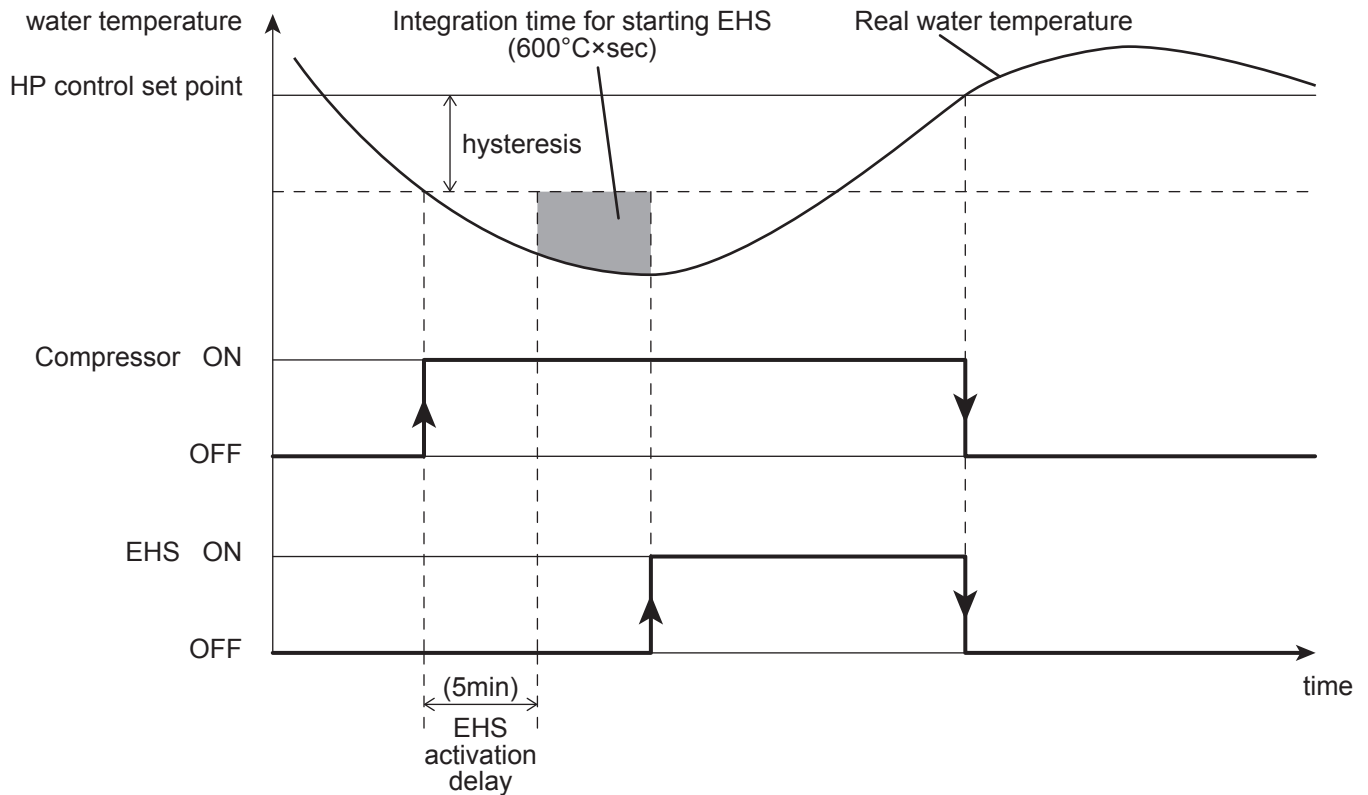

The “HP control set point” is equal to the value set for Fixed set point control, or by the value determined by the Climatic curve.

Parameters

Level	Parameter		Function description	Display & Input value				Remarks
	Group	Code		Default	min.	Max.	Unit	
I	47	00	EHS type of function 0=disable 1=Replacement mode 2=Supplementary mode	0	0	2	-	Par4600 and Par4700 are synchronize Par4600=1, 2, 3 → Par=4700=0
I	47	06	EHS activation delay time	5	0	900	1min	Par4700=1, 2 → Par4600=0
I	47	07	Integration time for starting EHS	600	0	900	1°C×sec	

8. Domestic Hot Water Production

Note1: The calculation of the Integration time only begins after the time set for Par4706 (EHS activation delay) has elapsed. The function is designed to prevent the EHS from starting in Supplementary mode, to allow the HP unit time to reach steady operation.

Note2: If the Integration time for starting the EHS is 0, control will be in stages, based on the control set point and the value set for the hysteresis.

Note3: If the HP unit shuts down due to the Outdoor air temperature being below its operating limit and due to the Max. water temperature produced based on the Outdoor air temperature, the heater will operate in Replacement mode.

Note4: If Terminal46 (Electric heater) will be enabled as Backup heater, the "EHS for space heating" will be not allowed. To guarantee correct operation, the two functions cannot be activated at the same time.

Must be allowed to define the Outdoor air temperature below which the water will be heated with Heat pump unit + EHS.

Set the parameters for Par4701=0 (always enabled), or Par4701=1 (depends on Outdoor air temperature).

If Par4701=0, EHS is ON based on Par4707 (Integration time for starting EHS) is enable regardless to the Outdoor air temperature.

If Par4701=1, EHS can be turned ON only if the both of the following conditions are met
 Par4704 (Outdoor air temperature to enable Backup heater)
 Par4707 (Integration time for starting heaters)

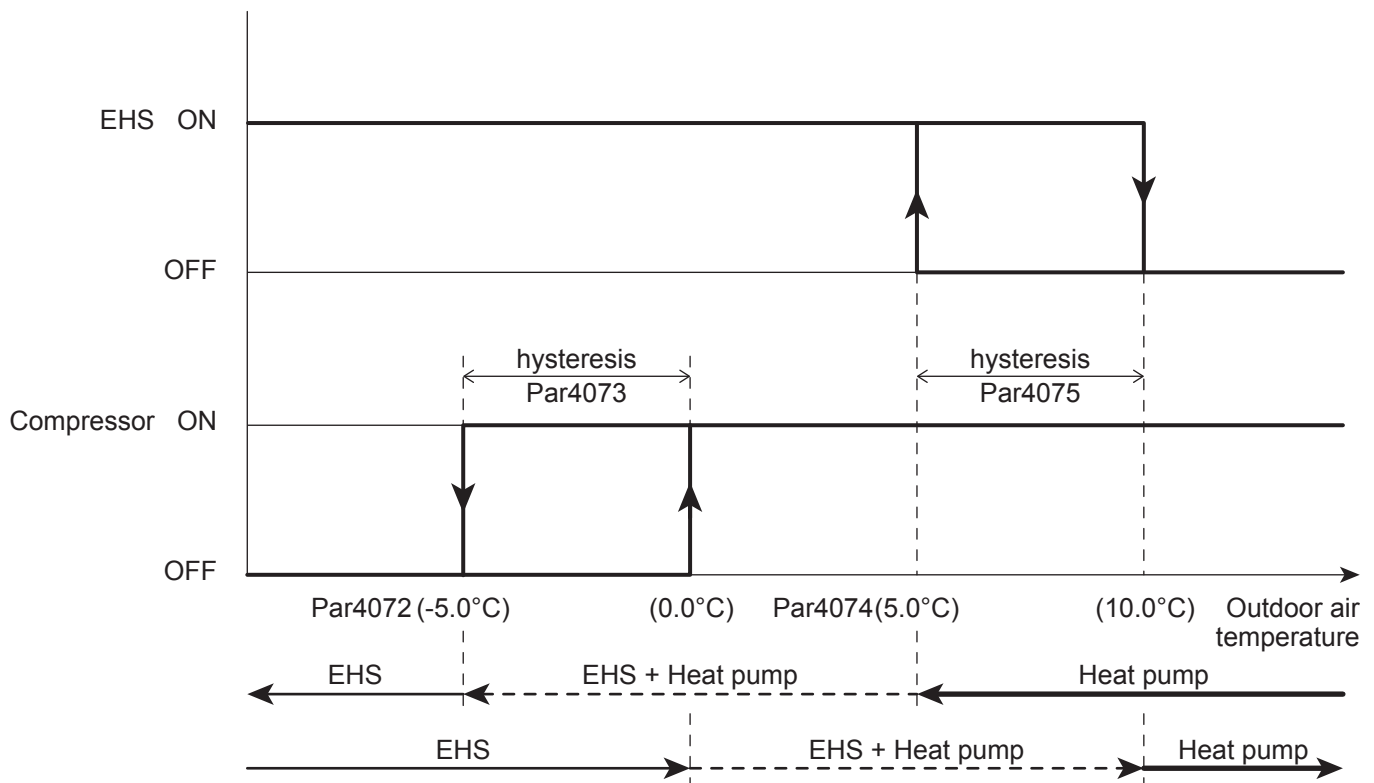

8. Domestic Hot Water Production

Parameters

Level	Parameter		Function description	Display & Input value				Remarks
	Group	Code		Default	min.	Max.	Unit	
I	47	00	EHS type of function 0=disable 1=Replacement mode 2=Supplementary mode	0	0	2	-	Par4600 and Par4700 are synchronized Par4600=1, 2, 3 → Par=4700=0 Par4700=1, 2 → Par4600=0
I	47	01	Conditions to be available EHS 0=always enabled 1=depends on Outdoor air temperature	1	0	1	-	
I	47	02	Outdoor air temperature to enable EHS and disable compressor	-5.0	-20.0	20.0	0.5°C	
I	47	03	Outdoor air temperature hysteresis to disable EHS and enable compressor	5.0	0.5	10.0	0.5°C	
I	47	04	Outdoor air temperature to enable EHS (Supplementary mode)	5.0	-20.0	20.0	0.5°C	
I	47	05	Outdoor air temperature hysteresis to disable EHS (Supplementary mode)	5.0	0.5	10.0	0.5°C	
I	51	41	Terminal 41-42 : EHS (External heat source for space heating) 0=disable 1=enable	0	0	1	-	

Note: If the Par4700=2 (Supplementary mode) is selected, the two parameters, Par4704 (Outdoor air temperature to enable EHS) and Par4705 (Outdoor air temperature hysteresis to disable EHS), have to be defined to manage the function correctly.

When the switching of the HP unit ON/OFF is based on water temperature set point, the EHS will be activated according to the water temperature set point based on "Fixed set point" or based on "Climatic curve".

When the switching of the HP unit ON/OFF is based on Room air temperature, the EHS will be activated according to the Room air temperature set point based on "Heat pump control".

9. Parameters List

9.1 Access limitation

There are three different levels of parameter setting. The access is limited to each level respectively. See "5.7 Procedure for accessing the Parameter setting menu" explaining the parameter setting of each level.

Access level

U=End User Level (accessible to end user, installer and service staff)

I =Installer Level (accessible to installer and service staff)

S=Service Level (accessible to service staff only)

*Service Level items are not stated in this Manual, but "Service Manual".

9.2 Parameter table

Parameters are comprised of four digits. First two-digit indicates Group (as shown below).

Group of parameters

- 01 : Read value of conditions and settings (Read only)
- 02 : Remote controller
- 04 : Fan coil system
- 11 : Time bands settings of Heating/Cooling (Zone1)
- 12 : Time bands settings of Heating/Cooling (Zone2)
- 13 : Time bands settings of DHW
- 21 : Water temperature set points of Heating/Cooling
- 31 : DHW (Domestic Hot Water)
- 41 : HP unit
- 42 : Water pump
- 43 : Frost protection
- 44 : Dehumidifier
- 45 : Mixing valve, 3way valve
- 46 : Backup heater
- 47 : EHS (External heat source)
- 51 : Input/Output

Read value of conditions and settings (Read only)

Level	Parameter		Function description	Display & Input value				Remarks
	Group	Code		Default	min.	Max.	Unit	
U	01	00	Return water temperature	-	-20	100	1°C	monitor display No.d0
U	01	01	Compressor operating frequency	-	0	200	1Hz	monitor display No.d1
U	01	02	Discharge temperature	-	-20	150	1°C	monitor display No.d2
U	01	03	Current consumption value	-	0	9900	100W	monitor display No.d3
U	01	04	Fan control number of rotation	-	0	1000	10rpm	
U	01	05	Defrost temperature	-	-20	100	1°C	monitor display No.d5
U	01	06	Outdoor air temperature	-	-20	100	1°C	monitor display No.d6
U	01	07	Water pump control number of rotation	-	0	9900	100rpm	monitor display No.d7
U	01	09	Outgoing water temperature	-	-20	100	1°C	monitor display No.d9

9. Parameters List

Read value of conditions and settings (Read only)

Level	Parameter		Function description	Display & Input value				Remarks
	Group	Code		Default	min.	Max.	Unit	
U	01	10	Selected operating mode 0=Heating/Cooling OFF 1=Heating 2=Cooling	0	0	2	-	Set by Remote controller or remote contact
U	01	11	Room air set temperature of Zone1(Master)	25.0	12.0	40.0	0.5°C	Set by Master Remote controller
U	01	12	Room air set temperature of Zone2(Slave)	25.0	12.0	40.0	0.5°C	Set by Slave Remote controller
U	01	13	Selected DHW operating mode 0=disable 1=Comfort 2=Economy 3=Force	0	0	3	-	Set by Remote controller
U	01	14	Day 0=Monday, 1=Tuesday, 2=Wednesday, 3=Thursday, 4=Friday,5=Saturday, 6=Sunday	0	0	6	-	
U	01	15	Clock	12:00	0:00	23:59	1min	
U	01	16	Heating/Cooling time bands setting Zone1 0=disable 1=active (Comfort or Economy)	0	0	1	-	
U	01	17	Heating/Cooling time bands setting Zone2 0=disable 1=active (Comfort or Economy)	0	0	1	-	
U	01	18	DHW time band setting 0=disable 1=enable	0	0	1	-	
U	01	19	Low tariff and Night mode setting 0=disable 1=Low tariff 2=Night mode 3=Low tariff and Night mode	0	0	3	-	Set by Remote controller or remote contact
U	01	20	Room relative humidity value	-	0	100	1%	
I	01	21	Integration electricity time	-	0	9999	x10Hr	
I	01	22	Integration operation time	-	0	9999	x10Hr	
I	01	23	Integration Heating operation time	-	0	9999	x10Hr	
I	01	24	Integration Cooling operation time	-	0	9999	x10Hr	
I	01	25	Integration DHW operation time	-	0	9999	x10Hr	
I	01	26	Software version number of Main PCB	-	0	9999	-	
I	01	27	Software version number of Control PCB	-	0	9999	-	
I	01	28	Software version number of Remote controller (Master)	-	0	9999	-	
I	01	29	Software version number of Remote controller (Slave)	-	0	9999	-	
I	01	31	DHW tank temperature (Terminal 7-8)	-	-20.0	100.0	0.5°C	
I	01	32	Outdoor air temperature (Terminal 9-10)	-	-20.0	100.0	0.5°C	
I	01	33	Buffer tank temperature (Terminal 11-12)	-	-20.0	100.0	0.5°C	
I	01	34	Mix water temperature (Terminal 13-14)	-	-20.0	100.0	0.5°C	
I	01	35	Humidity sensor (Terminal 17-18)	-	0	100	1%	
I	01	36	DHW remote contact (Terminal 18-19) 0=open 1=close	-	0	1	-	
I	01	37	Configurable input (Terminal 20-21) 0=open 1=close	-	0	1	-	
I	01	38	Dual set point control (Terminal 22-23) 0=open 1=close	-	0	1	-	
I	01	39	Heating/Cooling mode remote contact (Terminal 24-25) 0=open 1=close	-	0	1	-	
I	01	40	Flow switch (Terminal 26-27) 0=open 1=close	-	0	1	-	
I	01	41	Night mode (Terminal 28-29) 0=open 1=close	-	0	1	-	
I	01	42	Low tariff (Terminal 30-31) 0=open 1=close	-	0	1	-	

9. Parameters List

Read value of conditions and settings (Read only)

Level	Parameter		Function description	Display & Input value				Remarks
	Group	Code		Default	min.	Max.	Unit	
I	01	43	Current flow value	0.0	0.0	99.9	0.1L/min	
I	01	44	Current capacity value	0	0	9999	x10W	
I	01	45	Current consumption value	0	0	9999	W	
I	01	46	Current COP value	0	0	9999	x0.01	
I	01	70	Room temperature of Zone1	-	12.0	40.0	0.5°C	
I	01	71	Room temperature of Zone2	-	12.0	40.0	0.5°C	
U	01	72	Plate heat exchanger temperature	-	-20	100	1°C	

Remote controller

Level	Parameter		Function description	Display & Input value				Remarks
	Group	Code		Default	min.	Max.	Unit	
I	02	01	Adjust the temperature read by the sensor in Remote controller	0	-5.0	5.0	0.1°C	Master Remote controller
U	02	02	Sound ON/OFF of buzzer 0=OFF 1=ON	1	0	1	-	
U	02	03	Back light display at door open 0=OFF 1=ON	1	0	1	-	
U	02	04	Time to turn off the back light	60	10	300	10sec	
U	02	05	Time to back to normal indication	120	10	300	10sec	
U	02	06	Long pressing time to accept the button	3	2	5	1sec	Master/Slave Remote controller
I	02	11	Adjust the temperature read by the sensor in Remote controller	0	-5.0	5.0	0.1°C	Slave Remote controller
U	02	12	Sound ON/OFF of buzzer 0=OFF 1=ON	1	0	1	-	
U	02	13	Back light display at door open 0=OFF 1=ON	1	0	1	-	
U	02	14	Time to turn off the back light	60	10	300	10sec	
U	02	15	Time to back to normal indication	120	10	300	10sec	

Fan coil system

Level	Parameter		Function description	Display & Input value				Remarks
	Group	Code		Default	min.	Max.	Unit	
I	04	00	Which Remote controller will measure the Room air temperature to stop Fan coil System 0=Master Remote controller 1=Slave Remote controller 2=Master or Slave Remote controller	0	0	2	-	
I	04	01	Hysteresis of Room air temperature to restart Fan coil system	1.0	0.5	10.0	0.5°C	

9. Parameters List

Time bands settings of Heating/Cooling (Zone1)

Level	Parameter		Function description	Display & Input value				Remarks
	Group	Code		Default	min.	Max.	Unit	
I	11	00	Time band is ON/OFF on Monday 0=OFF 1=ON	0	0	1	-	
I	11	01	Comfort room set temperature on Monday	20.0	12.0	40.0	0.5°C	
I	11	02	Economy room set temperature on Monday	18.0	12.0	40.0	0.5°C	
I	11	03	1st ON time on Monday	0:00	0:00	24:00	15min	
I	11	04	1st OFF time on Monday	0:00	0:00	24:00	15min	
I	11	05	2nd ON time on Monday	0:00	0:00	24:00	15min	
I	11	06	2nd OFF time on Monday	0:00	0:00	24:00	15min	
I	11	07	3rd ON time on Monday	0:00	0:00	24:00	15min	
I	11	08	3rd OFF time on Monday	0:00	0:00	24:00	15min	
I	11	10	Time band is ON/OFF on Tuesday 0=OFF 1=ON	0	0	1	-	
I	11	11	Comfort room set temperature on Tuesday	20.0	12.0	40.0	0.5°C	
I	11	12	Economy room set temperature on Tuesday	18.0	12.0	40.0	0.5°C	
I	11	13	1st ON time on Tuesday	0:00	0:00	24:00	15min	
I	11	14	1st OFF time on Tuesday	0:00	0:00	24:00	15min	
I	11	15	2nd ON time on Tuesday	0:00	0:00	24:00	15min	
I	11	16	2nd OFF time on Tuesday	0:00	0:00	24:00	15min	
I	11	17	3rd ON time on Tuesday	0:00	0:00	24:00	15min	
I	11	18	3rd OFF time on Tuesday	0:00	0:00	24:00	15min	
I	11	20	Time band is ON/OFF on Wednesday 0=OFF 1=ON	0	0	1	-	
I	11	21	Comfort room set temperature on Wednesday	20.0	12.0	40.0	0.5°C	
I	11	22	Economy room set temperature on Wednesday	18.0	12.0	40.0	0.5°C	
I	11	23	1st ON time on Wednesday	0:00	0:00	24:00	15min	
I	11	24	1st OFF time on Wednesday	0:00	0:00	24:00	15min	
I	11	25	2nd ON time on Wednesday	0:00	0:00	24:00	15min	
I	11	26	2nd OFF time on Wednesday	0:00	0:00	24:00	15min	
I	11	27	3rd ON time on Wednesday	0:00	0:00	24:00	15min	
I	11	28	3rd OFF time on Wednesday	0:00	0:00	24:00	15min	
I	11	30	Time band is ON/OFF on Thursday 0=OFF 1=ON	0	0	1	-	
I	11	31	Comfort room set temperature on Thursday	20.0	12.0	40.0	0.5°C	
I	11	32	Economy room set temperature on Thursday	18.0	12.0	40.0	0.5°C	
I	11	33	1st ON time on Thursday	0:00	0:00	24:00	15min	
I	11	34	1st OFF time on Thursday	0:00	0:00	24:00	15min	
I	11	35	2nd ON time on Thursday	0:00	0:00	24:00	15min	
I	11	36	2nd OFF time on Thursday	0:00	0:00	24:00	15min	
I	11	37	3rd ON time on Thursday	0:00	0:00	24:00	15min	
I	11	38	3rd OFF time on Thursday	0:00	0:00	24:00	15min	
I	11	40	Time band is ON/OFF on Friday 0=OFF 1=ON	0	0	1	-	
I	11	41	Comfort room set temperature on Friday	20.0	12.0	40.0	0.5°C	
I	11	42	Economy room set temperature on Friday	18.0	12.0	40.0	0.5°C	
I	11	43	1st ON time on Friday	0:00	0:00	24:00	15min	
I	11	44	1st OFF time on Friday	0:00	0:00	24:00	15min	
I	11	45	2nd ON time on Friday	0:00	0:00	24:00	15min	
I	11	46	2nd OFF time on Friday	0:00	0:00	24:00	15min	
I	11	47	3rd ON time on Friday	0:00	0:00	24:00	15min	
I	11	48	3rd OFF time on Friday	0:00	0:00	24:00	15min	

9. Parameters List

Time bands settings of Heating/Cooling (Zone1)

Level	Parameter		Function description	Display & Input value				Remarks
	Group	Code		Default	min.	Max.	Unit	
I	11	50	Time band is ON/OFF on Saturday 0=OFF 1=ON	0	0	1	-	
I	11	51	Comfort room set temperature on Saturday	20.0	12.0	40.0	0.5°C	
I	11	52	Economy room set temperature on Saturday	18.0	12.0	40.0	0.5°C	
I	11	53	1st ON time on Saturday	0:00	0:00	24:00	15min	
I	11	54	1st OFF time on Saturday	0:00	0:00	24:00	15min	
I	11	55	2nd ON time on Saturday	0:00	0:00	24:00	15min	
I	11	56	2nd OFF time on Saturday	0:00	0:00	24:00	15min	
I	11	57	3rd ON time on Saturday	0:00	0:00	24:00	15min	
I	11	58	3rd OFF time on Saturday	0:00	0:00	24:00	15min	
I	11	60	Time band is ON/OFF on Sunday 0=OFF 1=ON	0	0	1	-	
I	11	61	Comfort room set temperature on Sunday	20.0	12.0	40.0	0.5°C	
I	11	62	Economy room set temperature on Sunday	18.0	12.0	40.0	0.5°C	
I	11	63	1st ON time on Sunday	0:00	0:00	24:00	15min	
I	11	64	1st OFF time on Sunday	0:00	0:00	24:00	15min	
I	11	65	2nd ON time on Sunday	0:00	0:00	24:00	15min	
I	11	66	2nd OFF time on Sunday	0:00	0:00	24:00	15min	
I	11	67	3rd ON time on Sunday	0:00	0:00	24:00	15min	
I	11	68	3rd OFF time on Sunday	0:00	0:00	24:00	15min	
I	11	70	Time band is ON/OFF on Weekday (5days) 0=OFF 1=ON	0	0	1	-	
I	11	71	Comfort room set temperature on Weekday (5days)	20.0	12.0	40.0	0.5°C	
I	11	72	Economy room set temperature on Weekday (5days)	18.0	12.0	40.0	0.5°C	
I	11	73	1st ON time on Weekday (5days)	0:00	0:00	24:00	15min	
I	11	74	1st OFF time on Weekday (5days)	0:00	0:00	24:00	15min	
I	11	75	2nd ON time on Weekday (5days)	0:00	0:00	24:00	15min	
I	11	76	2nd OFF time on Weekday (5days)	0:00	0:00	24:00	15min	
I	11	77	3rd ON time on Weekday (5days)	0:00	0:00	24:00	15min	
I	11	78	3rd OFF time on Weekday (5days)	0:00	0:00	24:00	15min	
I	11	80	Time band is ON/OFF on Weekend (2days) 0=OFF 1=ON	0	0	1	-	
I	11	81	Comfort room set temperature on Weekend (2days)	20.0	12.0	40.0	0.5°C	
I	11	82	Economy room set temperature on Weekend (2days)	18.0	12.0	40.0	0.5°C	
I	11	83	1st ON time on Weekend (2days)	0:00	0:00	24:00	15min	
I	11	84	1st OFF time on Weekend (2days)	0:00	0:00	24:00	15min	
I	11	85	2nd ON time on Weekend (2days)	0:00	0:00	24:00	15min	
I	11	86	2nd OFF time on Weekend (2days)	0:00	0:00	24:00	15min	
I	11	87	3rd ON time on Weekend (2days)	0:00	0:00	24:00	15min	
I	11	88	3rd OFF time on Weekend (2days)	0:00	0:00	24:00	15min	
I	11	90	Time band is ON/OFF on Everyday (7days) 0=OFF 1=ON	0	0	1	-	
I	11	91	Comfort room set temperature on Everyday (7days)	20.0	12.0	40.0	0.5°C	
I	11	92	Economy room set temperature on Everyday (7days)	18.0	12.0	40.0	0.5°C	
I	11	93	1st ON time on Everyday (7days)	0:00	0:00	24:00	15min	
I	11	94	1st OFF time on Everyday (7days)	0:00	0:00	24:00	15min	
I	11	95	2nd ON time on Everyday (7days)	0:00	0:00	24:00	15min	
I	11	96	2nd OFF time on Everyday (7days)	0:00	0:00	24:00	15min	
I	11	97	3rd ON time on Everyday (7days)	0:00	0:00	24:00	15min	
I	11	98	3rd OFF time on Everyday (7days)	0:00	0:00	24:00	15min	

9. Parameters List

Time bands settings of Heating/Cooling (Zone2)

Level	Parameter		Function description	Display & Input value				Remarks
	Group	Code		Default	min.	Max.	Unit	
I	12	00	Time band is ON/OFF on Monday 0=OFF 1=ON	0	0	1	-	
I	12	01	Comfort room set temperature on Monday	20.0	12.0	40.0	0.5°C	
I	12	02	Economy room set temperature on Monday	18.0	12.0	40.0	0.5°C	
I	12	03	1st ON time on Monday	0:00	0:00	24:00	15min	
I	12	04	1st OFF time on Monday	0:00	0:00	24:00	15min	
I	12	05	2nd ON time on Monday	0:00	0:00	24:00	15min	
I	12	06	2nd OFF time on Monday	0:00	0:00	24:00	15min	
I	12	07	3rd ON time on Monday	0:00	0:00	24:00	15min	
I	12	08	3rd OFF time on Monday	0:00	0:00	24:00	15min	
I	12	10	Time band is ON/OFF on Tuesday 0=OFF 1=ON	0	0	1	-	
I	12	11	Comfort room set temperature on Tuesday	20.0	12.0	40.0	0.5°C	
I	12	12	Economy room set temperature on Tuesday	18.0	12.0	40.0	0.5°C	
I	12	13	1st ON time on Tuesday	0:00	0:00	24:00	15min	
I	12	14	1st OFF time on Tuesday	0:00	0:00	24:00	15min	
I	12	15	2nd ON time on Tuesday	0:00	0:00	24:00	15min	
I	12	16	2nd OFF time on Tuesday	0:00	0:00	24:00	15min	
I	12	17	3rd ON time on Tuesday	0:00	0:00	24:00	15min	
I	12	18	3rd OFF time on Tuesday	0:00	0:00	24:00	15min	
I	12	20	Time band is ON/OFF on Wednesday 0=OFF 1=ON	0	0	1	-	
I	12	21	Comfort room set temperature on Wednesday	20.0	12.0	40.0	0.5°C	
I	12	22	Economy room set temperature on Wednesday	18.0	12.0	40.0	0.5°C	
I	12	23	1st ON time on Wednesday	0:00	0:00	24:00	15min	
I	12	24	1st OFF time on Wednesday	0:00	0:00	24:00	15min	
I	12	25	2nd ON time on Wednesday	0:00	0:00	24:00	15min	
I	12	26	2nd OFF time on Wednesday	0:00	0:00	24:00	15min	
I	12	27	3rd ON time on Wednesday	0:00	0:00	24:00	15min	
I	12	28	3rd OFF time on Wednesday	0:00	0:00	24:00	15min	
I	12	30	Time band is ON/OFF on Thursday 0=OFF 1=ON	0	0	1	-	
I	12	31	Comfort room set temperature on Thursday	20.0	12.0	40.0	0.5°C	
I	12	32	Economy room set temperature on Thursday	18.0	12.0	40.0	0.5°C	
I	12	33	1st ON time on Thursday	0:00	0:00	24:00	15min	
I	12	34	1st OFF time on Thursday	0:00	0:00	24:00	15min	
I	12	35	2nd ON time on Thursday	0:00	0:00	24:00	15min	
I	12	36	2nd OFF time on Thursday	0:00	0:00	24:00	15min	
I	12	37	3rd ON time on Thursday	0:00	0:00	24:00	15min	
I	12	38	3rd OFF time on Thursday	0:00	0:00	24:00	15min	
I	12	40	Time band is ON/OFF on Friday 0=OFF 1=ON	0	0	1	-	
I	12	41	Comfort room set temperature on Friday	20.0	12.0	40.0	0.5°C	
I	12	42	Economy room set temperature on Friday	18.0	12.0	40.0	0.5°C	
I	12	43	1st ON time on Friday	0:00	0:00	24:00	15min	
I	12	44	1st OFF time on Friday	0:00	0:00	24:00	15min	
I	12	45	2nd ON time on Friday	0:00	0:00	24:00	15min	
I	12	46	2nd OFF time on Friday	0:00	0:00	24:00	15min	
I	12	47	3rd ON time on Friday	0:00	0:00	24:00	15min	
I	12	48	3rd OFF time on Friday	0:00	0:00	24:00	15min	

9. Parameters List

Time bands settings of Heating/Cooling (Zone2)

Level	Parameter		Function description	Display & Input value				Remarks
	Group	Code		Default	min.	Max.	Unit	
I	12	50	Time band is ON/OFF on Saturday 0=OFF 1=ON	0	0	1	-	
I	12	51	Comfort room set temperature on Saturday	20.0	12.0	40.0	0.5°C	
I	12	52	Economy room set temperature on Saturday	18.0	12.0	40.0	0.5°C	
I	12	53	1st ON time on Saturday	0:00	0:00	24:00	15min	
I	12	54	1st OFF time on Saturday	0:00	0:00	24:00	15min	
I	12	55	2nd ON time on Saturday	0:00	0:00	24:00	15min	
I	12	56	2nd OFF time on Saturday	0:00	0:00	24:00	15min	
I	12	57	3rd ON time on Saturday	0:00	0:00	24:00	15min	
I	12	58	3rd OFF time on Saturday	0:00	0:00	24:00	15min	
I	12	60	Time band is ON/OFF on Sunday 0=OFF 1=ON	0	0	1	-	
I	12	61	Comfort room set temperature on Sunday	20.0	12.0	40.0	0.5°C	
I	12	62	Economy room set temperature on Sunday	18.0	12.0	40.0	0.5°C	
I	12	63	1st ON time on Sunday	0:00	0:00	24:00	15min	
I	12	64	1st OFF time on Sunday	0:00	0:00	24:00	15min	
I	12	65	2nd ON time on Sunday	0:00	0:00	24:00	15min	
I	12	66	2nd OFF time on Sunday	0:00	0:00	24:00	15min	
I	12	67	3rd ON time on Sunday	0:00	0:00	24:00	15min	
I	12	68	3rd OFF time on Sunday	0:00	0:00	24:00	15min	
I	12	70	Time band is ON/OFF on Weekday (5days) 0=OFF 1=ON	0	0	1	-	
I	12	71	Comfort room set temperature on Weekday (5days)	20.0	12.0	40.0	0.5°C	
I	12	72	Economy room set temperature on Weekday (5days)	18.0	12.0	40.0	0.5°C	
I	12	73	1st ON time on Weekday (5days)	0:00	0:00	24:00	15min	
I	12	74	1st OFF time on Weekday (5days)	0:00	0:00	24:00	15min	
I	12	75	2nd ON time on Weekday (5days)	0:00	0:00	24:00	15min	
I	12	76	2nd OFF time on Weekday (5days)	0:00	0:00	24:00	15min	
I	12	77	3rd ON time on Weekday (5days)	0:00	0:00	24:00	15min	
I	12	78	3rd OFF time on Weekday (5days)	0:00	0:00	24:00	15min	
I	12	80	Time band is ON/OFF on Weekend (2days) 0=OFF 1=ON	0	0	1	-	
I	12	81	Comfort room set temperature on Weekend (2days)	20.0	12.0	40.0	0.5°C	
I	12	82	Economy room set temperature on Weekend (2days)	18.0	12.0	40.0	0.5°C	
I	12	83	1st ON time on Weekend (2days)	0:00	0:00	24:00	15min	
I	12	84	1st OFF time on Weekend (2days)	0:00	0:00	24:00	15min	
I	12	85	2nd ON time on Weekend (2days)	0:00	0:00	24:00	15min	
I	12	86	2nd OFF time on Weekend (2days)	0:00	0:00	24:00	15min	
I	12	87	3rd ON time on Weekend (2days)	0:00	0:00	24:00	15min	
I	12	88	3rd OFF time on Weekend (2days)	0:00	0:00	24:00	15min	
I	12	90	Time band is ON/OFF on Everyday (7days) 0=OFF 1=ON	0	0	1	-	
I	12	91	Comfort room set temperature on Everyday (7days)	20.0	12.0	40.0	0.5°C	
I	12	92	Economy room set temperature on Everyday (7days)	18.0	12.0	40.0	0.5°C	
I	12	93	1st ON time on Everyday (7days)	0:00	0:00	24:00	15min	
I	12	94	1st OFF time on Everyday (7days)	0:00	0:00	24:00	15min	
I	12	95	2nd ON time on Everyday (7days)	0:00	0:00	24:00	15min	
I	12	96	2nd OFF time on Everyday (7days)	0:00	0:00	24:00	15min	
I	12	97	3rd ON time on Everyday (7days)	0:00	0:00	24:00	15min	
I	12	98	3rd OFF time on Everyday (7days)	0:00	0:00	24:00	15min	

9. Parameters List

Time bands settings of DHW

Level	Parameter		Function description	Display & Input value				Remarks
	Group	Code		Default	min.	Max.	Unit	
I	13	01	DHW Comfort 1st ON time	0:00	0:00	24:00	15min	
I	13	02	DHW Comfort 1st OFF time	0:00	0:00	24:00	15min	
I	13	03	DHW Comfort 2nd ON time	0:00	0:00	24:00	15min	
I	13	04	DHW Comfort 2nd OFF time	0:00	0:00	24:00	15min	
I	13	05	DHW Comfort 3rd ON time	0:00	0:00	24:00	15min	
I	13	06	DHW Comfort 3rd OFF time	0:00	0:00	24:00	15min	
I	13	11	Low tariff 1st ON time	0:00	0:00	24:00	15min	
I	13	12	Low tariff 1st OFF time	0:00	0:00	24:00	15min	
I	13	13	Low tariff 2nd ON time	0:00	0:00	24:00	15min	
I	13	14	Low tariff 2nd OFF time	0:00	0:00	24:00	15min	
I	13	15	Low tariff 3rd ON time	0:00	0:00	24:00	15min	
I	13	16	Low tariff 3rd OFF time	0:00	0:00	24:00	15min	
I	13	21	Night mode 1st ON time	0:00	0:00	24:00	15min	
I	13	22	Night mode 1st OFF time	0:00	0:00	24:00	15min	
I	13	23	Night mode 2nd ON time	0:00	0:00	24:00	15min	
I	13	24	Night mode 2nd OFF time	0:00	0:00	24:00	15min	
I	13	25	Night mode 3rd ON time	0:00	0:00	24:00	15min	
I	13	26	Night mode 3rd OFF time	0:00	0:00	24:00	15min	

Water temperature set points of Heating/Cooling

Level	Parameter		Function description	Display & Input value				Remarks
	Group	Code		Default	min.	Max.	Unit	
I	21	00	Heating Zone1, enable Outgoing water set point 0=Fixed set point 1=Climatic curve	0	0	1	-	
I	21	01	Heating Zone1, Fixed Outgoing water set point in Heating	45.0	23.0	75.0	0.5°C	
I	21	02	Max. Outgoing water temperature in Heating mode (Tm1) Zone1	45.0	23.0	75.0	0.5°C	
I	21	03	Min. Outgoing water temperature in Heating mode (Tm2) Zone1	30.0	23.0	75.0	0.5°C	
I	21	04	Min. Outdoor air temperature corresponding to max. Outgoing water temperature (Te1) Zone1	0.0	-20.0	50.0	0.5°C	
I	21	05	Max. Outdoor air temperature corresponding to max. Outgoing water temperature (Te2) Zone1	20.0	0.0	40.0	0.5°C	
I	21	10	Heating Zone2, enable Outgoing water set point 0=Fixed set point 1=Climatic curve enabled	0	0	1	-	
I	21	11	Heating Zone2, Fixed Outgoing water set point in Heating.	45.0	23.0	75.0	0.5°C	
I	21	12	Max. Outgoing water temperature in Heating mode (Tm1) Zone2	45.0	23.0	75.0	0.5°C	
I	21	13	Min. Outgoing water temperature in Heating mode (Tm2) Zone2	30.0	23.0	75.0	0.5°C	
I	21	14	Min. Outdoor air temperature corresponding to max. Outgoing water temperature (Te1) Zone2	0.0	-20.0	50.0	0.5°C	
I	21	15	Max. Outdoor air temperature corresponding to max. Outgoing water temperature (Te2) Zone2	20.0	0.0	40.0	0.5°C	
I	21	20	Cooling Zone1, enable Outgoing water set point 0=Fixed set point 1=Climatic curve enabled	0	0	1	-	
I	21	21	Cooling Zone1, Fixed Outgoing water set point in Cooling	7.0	7.0	23.0	0.5°C	
I	21	22	Max. Outgoing water temperature in Cooling mode (Tm1) Zone1	20.0	7.0	23.0	0.5°C	
I	21	23	Min. Outgoing water temperature in Cooling mode (Tm2) Zone1	18.0	7.0	23.0	0.5°C	

9. Parameters List

Water temperature set points of Heating/Cooling

Level	Parameter		Function description	Display & Input value				Remarks
	Group	Code		Default	min.	Max.	Unit	
I	21	24	Min. Outdoor air temperature corresponding to max. Outgoing water temperature (Te1) Zone1	25.0	0.0	50.0	0.5°C	
I	21	25	Max. Outdoor air temperature corresponding to max. Outgoing water temperature (Te2) Zone1	35.0	0.0	50.0	0.5°C	
I	21	30	Cooling Zone2, enable Outgoing water set point 0=Fixed set point 1=Climatic Curve Enabled	0	0	1	-	
I	21	31	Cooling Zone2, Fixed Outgoing water set point in Cooling	7.0	7.0	23.0	0.5°C	
I	21	32	Max. Outgoing water temperature in Cooling mode (Tm1) Zone2	20.0	7.0	23.0	0.5°C	
I	21	33	Min. Outgoing water temperature in Cooling mode (Tm2) Zone2	18.0	7.0	23.0	0.5°C	
I	21	34	Min. Outdoor air temperature corresponding to max. Outgoing water temperature (Te1) Zone2	25.0	0.0	50.0	0.5°C	
I	21	35	Max. Outdoor air temperature corresponding to max. Outgoing water temperature (Te2) Zone2	35.0	0.0	50.0	0.5°C	
I	21	41	Hysteresis of water set point in Heating and DHW	8.0	4.0	10.0	0.5°C	
I	21	42	Hysteresis of water set point in Cooling	8.0	4.0	10.0	0.5°C	
I	21	51	Low tariff deferential water set point for Heating	5.0	0.0	60.0	0.5°C	
I	21	52	Low tariff deferential water set point for Cooling	5.0	0.0	60.0	0.5°C	
I	21	61	Buffer tank set point for Heating	45.0	23.0	75.0	0.5°C	
I	21	62	Buffer tank set point for Cooling	7.0	7.0	23.0	0.5°C	

DHW (Domestic Hot Water)

Level	Parameter		Function description	Display & Input value				Remarks
	Group	Code		Default	min.	Max.	Unit	
I	31	01	DHW production priority setting 0=DHW is unavailable 1=DHW is available, and priority DHW over space Heating 2=DHW is available, and priority space Heating over DHW	0	0	2	-	
I	31	02	Type of configuration to heat the DHW 0=Heat pump + Heater 1=Heat pump only 2=Heater only	1	0	2	-	
I	31	11	DHW Comfort set temperature	50.0	40.0	75.0	0.5°C	
I	31	12	DHW Economy set temperature	40.0	30.0	65.0	0.5°C	
I	31	13	DHW set point hysteresis	3.0	1.0	10.0	0.5°C	
I	31	14	DHW Over boost mode set point	60.0	50.0	90.0	0.5°C	
I	31	15	DHW Over boost mode set point hysteresis	5.0	0.5	10.0	0.5°C	
I	31	21	Max. time for DHW request	60	0	900	1min	
I	31	22	Min. time for space Heating/Cooling	15	0	900	1min	
I	31	32	Conditions to be available DHW heaters 0=always enabled 1=depends on Outdoor air temperature	1	0	1	-	
I	31	33	Outdoor air temperature to enable DHW heaters	-5.0	-20.0	20.0	0.5°C	
I	31	34	Outdoor air temperature hysteresis to disable DHW heaters	5.0	0.5	10.0	0.5°C	
I	31	40	Anti-legionella function 0=disable 1=enable	0	0	1	-	
I	31	41	Anti-legionella operation day of week 0=Mon, 1=Tue, 2=Wed, 3=Thu, 4=Fri, 5=Sat, 6=Sun	0	0	6	-	
I	31	42	Start time of the day at which the DHW should be heated for Anti-legionella	1:00	0:00	23:00	1:00	

9. Parameters List

HP unit

Level	Parameter		Function description	Display & Input value				Remarks
	Group	Code		Default	min.	Max.	Unit	
I	41	00	The HP unit turns ON/OFF based on 0=Room set point 1=Water set point	1	0	1	-	
I	41	01	Hysteresis of Heating Room air set point	0.5	0.5	5.0	0.5°C	
I	41	02	Hysteresis of Cooling Room air set point	0.5	0.5	5.0	0.5°C	
I	41	11	Max. frequency of Night mode	80	50	100	5%	
I	41	21	Min. time compressor ON – OFF time	0	0	0	1sec	
I	41	22	Delay time pump OFF from compressor OFF	30	0	900	1sec	
I	41	23	Delay time compressor ON from pump ON	30	0	900	1sec	
I	41	24	Circulating water concentration correction factor	100	90	100	1%	

Water pump

Level	Parameter		Function description	Display & Input value				Remarks
	Group	Code		Default	min.	Max.	Unit	
I	42	00	Type of configuration of Main water pump 0=always ON 1=ON/OFF based on Buffer tank temperature 2=ON/OFF based on Sniffing cycles	0	0	2	-	To be set to the following combinations Par5111=0 →Par4200=0 or 2 Par5111=1 →Par4200=0 or 1 or 2
I	42	01	Time ON Main water pump for Sniffing cycle	3	1	15	1min	
I	42	02	Time OFF Main water pump	5	5	30	1min	
I	42	03	Delay time OFF Main water pump from OFF compressor	3	1	15	1min	
I	42	11	OFF time for Unlock pump function start	48	0	240	1Hr	
I	42	12	Time ON Main water pump for Unlock pump function	5	0	10	1sec	
I	42	13	Time ON water pump1 for Unlock pump function	5	0	10	1sec	
I	42	14	Time ON water pump2 for Unlock pump function	5	0	10	1sec	
I	42	20	Type of operation of additional water pump1 0=disable 1=depending on Main water pump setting 2=depending on Main water pump setting but always OFF when the DHW mode is activated 3=always ON, apart if any alarms are activated or if the HP unit is in OFF mode 4=ON/OFF based on Room air temperature	0	0	4	-	
I	42	21	Type of operation of additional water pump2 0=disable 1=depending on Main water pump setting 2=depending on Main water pump setting but always OFF when the DHW mode is activated 3=always ON, apart if any alarms are activated or if the HP unit is in OFF mode. 4=ON/OFF based on Room air temperature	0	0	4	-	

9. Parameters List

Frost protection

Level	Parameter		Function description	Display & Input value				Remarks
	Group	Code		Default	min.	Max.	Unit	
I	43	00	Frost protection on room temperature 0=disable 1=enable	1	0	1	-	
I	43	01	Start temperature of Frost protection on Room air temperature	14.0	0.0	40.0	0.5°C	
I	43	02	Hysteresis of Room air temperature of Frost protection	1.0	0.5	5.0	0.5°C	
I	43	03	Water temperature of Frost protection	35.0	10.0	75.0	0.5°C	
I	43	04	Delay time OFF Main water pump from OFF Frost protection operation function	30	0	120	1sec	
I	43	10	Frost protection by Outdoor air temperature 0=disable 1=enable	1	0	1	-	
I	43	11	Start temperature of Frost protection on Outdoor air temperature	4.0	0.0	10.0	0.5°C	
I	43	12	Hysteresis of Outdoor air temperature	3.0	0.5	5.0	0.5°C	
I	43	13	Backup heater set point during Frost protection	4.0	0.0	10.0	0.5°C	
I	43	14	Hysteresis of Outgoing water temperature	3.0	0.5	5.0	0.5°C	
I	43	20	Frost protection based on Outgoing water temperature 0=disable 1=enable	1	0	1	-	
I	43	21	Start temperature of Frost protection on Outgoing water temperature	4.0	0.0	10.0	0.5°C	
I	43	22	Hysteresis of Outgoing water temperature	3.0	0.5	5.0	0.5°C	
I	43	31	Start temperature of Frost protection on DHW tank temperature	5.0	0.0	60.0	0.5°C	
I	43	32	Hysteresis of DHW tank temperature	3.0	0.5	5.0	0.5°C	

Dehumidifier

Level	Parameter		Function description	Display & Input value				Remarks
	Group	Code		Default	min.	Max.	Unit	
I	44	01	Room relative humidity value	60	0	100	1%	
I	44	02	Hysteresis value	10	1	100	1%	
I	44	03	Humidity sensor property, Voltage value1	0.0	0.0	10.0	0.1V	
I	44	04	Humidity sensor property, Voltage value2	10.0	0.0	10.0	0.1V	
I	44	05	Humidity sensor property, Function value1	0	0	100	1%	
I	44	06	Humidity sensor property, Function value2	100	0	100	1%	
I	44	10	Compensation for room humidity 0=disable 1=enable	1	0	1	-	
I	44	11	Room relative humidity value to start increasing Outgoing water temperature set point	55	0	100	1%	
I	44	12	Max. Outgoing temperature hysteresis corresponding to 100% relative humidity	10.0	0.5	20.0	0.5°C	

Mixing valve, 3way valve

Level	Parameter		Function description	Display & Input value				Remarks
	Group	Code		Default	min.	Max.	Unit	
I	45	01	Mixing valve runtime (from the fully closed to the fully open position)	120	0	900	10sec	
I	45	11	3way valve change over time	60	1	900	1sec	

9. Parameters List

Backup heater

Level	Parameter		Function description	Display & Input value				Remarks
	Group	Code		Default	min.	Max.	Unit	
I	46	00	Backup heater type of function 0=disable 1=Replacement mode 2=Emergency mode 3=Supplementary mode	0	0	3	-	Par4600 and Par4700 are synchronized Par4600=1, 2, 3 →Par4700=0 Par470=1, 2 →Par4600=0
I	46	01	Manual water set point	50.0	40.0	75.0	0.5°C	
I	46	02	Manual water temperature hysteresis	5.0	0.5	10.0	0.5°C	
I	46	04	Heater activation delay time	5	0	900	1min	
I	46	05	Integration time for starting heaters	600	0	900	°C×sec	(Outgoing water temperature – Actual temperature) x Integration time calculate every 1sec.
I	46	10	Conditions to be available Backup heaters 0=always enabled 1=depends on Outdoor air temperature	1	0	1	-	
I	46	11	Outdoor air temperature to enable Backup heaters and disable compressor	-5.0	-20.0	20.0	0.5°C	
I	46	12	Outdoor air temperature hysteresis to disable Backup heaters and enable compressor	5.0	0.5	10.0	0.5°C	
I	46	13	Outdoor air temperature to enable Backup heaters (Supplementary mode)	5.0	-20.0	20.0	0.5°C	
I	46	14	Outdoor air temperature hysteresis to disable Backup heaters (Supplementary mode)	5.0	0.5	10.0	0.5°C	
I	46	20	Freeze protection functions 0=disable 1=enabled during Start-up 2=enabled during Defrost 3=enabled during Start-up and Defrost	0	0	3	-	
I	46	21	Outgoing water temperature set point during Start-up	8.0	0.0	60.0	0.5°C	
I	46	22	Hysteresis water temperature set point during Start-up	5.0	0.5	10.0	0.5°C	
I	46	23	Outgoing water temperature set point during Defrost	24.0	10.0	50.0	0.5°C	
I	46	24	Hysteresis water temperature set point during Defrost	5.0	0.5	10.0	0.5°C	

EHS (External heat source)

Level	Parameter		Function description	Display & Input value				Remarks
	Group	Code		Default	min.	Max.	Unit	
I	47	00	EHS type of function 0=disable 1=Replacement mode 2=Supplementary mode	0	0	2	-	Par4600 and Par4700 are synchronized Par4600=1, 2, 3 →Par4700=0 Par470=1, 2 →Par4600=0
I	47	01	Conditions to be available EHS 0=always enabled 1=depends on Outdoor air temperature	1	0	1	-	
I	47	02	Outdoor air temperature to enable EHS and disable compressor	-5.0	-20.0	20.0	0.5°C	
I	47	03	Outdoor air temperature hysteresis to disable EHS and enable compressor	5.0	0.5	10.0	0.5°C	
I	47	04	Outdoor air temperature to enable EHS (Supplementary mode)	5.0	-20.0	20.0	0.5°C	
I	47	05	Outdoor air temperature hysteresis to disable EHS (Supplementary mode)	5.0	0.5	10.0	0.5°C	
I	47	06	EHS activation delay time	5	0	900	1min	
I	47	07	Integration time for starting EHS	600	0	900	°C×sec	(Outgoing water temperature – Actual temperature) x Integration time Calculate every 1 sec

9. Parameters List

Input/Output

Level	Parameter		Function description	Display & Input value				Remarks
	Group	Code		Default	min.	Max.	Unit	
I	51	01	Terminal 1-2-3 : Remote Controller 1=enable	1	1	1	-	
I	51	04	Terminal 4-5-6 : 3way mixing valve 0=disable 1=enable	0	0	1	-	
I	51	07	Terminal 7-8 : DHW tank temperature probe 0=disable 1=enable	0	0	1	-	
I	51	09	Terminal 9-10 : Outdoor air temperature probe (additional) 0=disable 1=enable	0	0	1	-	
I	51	11	Terminal 11-12 : Buffer tank temperature probe 0=disable 1=enable	0	0	1	-	To be set to the following combinations Par5111=0 →Par4200=0 or 2 Par5111=1 →Par4200=0 or 1 or 2
I	51	13	Terminal 13-14 : Mix Water temperature probe 0=disable 1=enable	0	0	1	-	
I	51	15	Terminal 15-16-32 : RS485 Mod Bus 0=disable 1=enable	1	0	1	-	
I	51	17	Terminal 17-18 : Humidity sensor 0=disable 1=enable	0	0	1	-	
I	51	19	Terminal 19-18 : DHW remote contact 0=disable (Remote controller only) 1=enable	0	0	1	-	
I	51	20	Terminal 20-21 : ON/OFF remote contact or EHS Alarm input 0=disable (Remote controller only) 1=ON/OFF remote contact 2=EHS Alarm input	0	0	2	-	ON/OFF by Remote controller 0=enable 1=ON/disable OFF/enable 2=enable
I	51	22	Terminal 22-23 : Dual set point control 0=disable 1=enable	1	0	1	-	
I	51	24	Terminal 24-25 : Heating/Cooling mode remote contact 0=disable (Remote controller only) 1=Cooling is CLOSE contact, Heating is OPEN contact. 2=Cooling is OPEN contact, Heating is CLOSE contact	0	0	2	-	
I	51	26	Terminal 26-27 : Flow switch 0=disable 1=enable	1	0	1	-	
I	51	28	Terminal 28-29 : Night mode 0=disable (Remote controller only) 1=enable	0	0	1	-	Par5128 and Par5130 are synchronized in same value
I	51	30	Terminal 30-31 : Low tariff 0=disable (Remote controller only) 1=enable	0	0	1	-	
I	51	41	Terminal 41-42 : EHS (External heat source for space heating) 0=disable 1=enable	0	0	1	-	
I	51	43	Terminal 43-44 : Heating/Cooling mode output 0=disable 1=Indication of Cooling mode (CLOSE=Cooling) 2=indication of Heating mode (CLOSE=Heating)	0	0	2	-	

9. Parameters List

Input/Output

Level	Parameter		Function description	Display & Input value				Remarks
	Group	Code		Default	min.	Max.	Unit	
I	51	45	Terminal 45 : Dehumidifier 0=disable 1=enable	0	0	1	-	
I	51	46	Terminal 46 : DHW Electric heater or Backup heater 0=DHW Electric heater 1=Backup heater	0	0	1	-	
I	51	47	Terminal 47 : Alarm (Configurable output) 0=disable 1=Alarm 2=Ambient temperature reached	0	0	2	-	
I	51	48	Terminal 48 : Pump1 0=disable 1=1st Additional water pump1 for Zone1	0	0	1	-	
I	51	49	Terminal 49 : Pump2 0=disable 1=2nd Additional water pump2 for Zone2	0	0	1	-	
I	51	50	Terminal 50-51-52 : DHW 3way valve 1=enable	1	1	1	-	

SG Ready

Level	Parameter		Function description	Display & Input value				Remarks
	Group	Code		Default	min.	Max.	Unit	
I	53	01	SG Ready 0=disable 1=enable	0	0	1	-	
I	53	02	Heating temperature added at Recommended Operation	3.0	0.0	52.0	0.5°C	
I	53	03	Cooling temperature reduced at Recommended Operation	3.0	0.0	16.0	0.5°C	
I	53	04	DHW temperature added at Recommended Operation	3.0	0.0	52.0	0.5°C	
I	53	05	Heating hysteresis at Recommended Operation	8.0	4.0	10.0	0.5°C	
I	53	06	Cooling hysteresis at Recommended Operation	8.0	4.0	10.0	0.5°C	
I	53	07	DHW hysteresis at Recommended Operation	8.0	4.0	10.0	0.5°C	
I	53	08	Heating temperature added at Forced Operation	5.0	0.0	52.0	0.5°C	
I	53	09	Cooling temperature reduced at Forced Operation	5.0	0.0	16.0	0.5°C	
I	53	10	DHW temperature added at Forced Operation	5.0	0.0	52.0	0.5°C	
I	53	11	Heating hysteresis at Forced Operation	8.0	4.0	10.0	0.5°C	
I	53	12	Cooling hysteresis at Forced Operation	8.0	4.0	10.0	0.5°C	
I	53	13	DHW hysteresis at Forced Operation	8.0	4.0	10.0	0.5°C	

10. Installation check and Test operation

Carefully explain the operation method to the customer using the manual.

Before starting the HP unit, check each item in the list below and put a tick mark in the .

10.1 Installation check

Locations and positioning

- The vibration damping feet are fitted
- The unit is fixed to the surface it rests on
- Maintenance clearance comply with the specifications in the manual
- The position of the outdoor air temperature probe complies with the information of the manual
- The position of the room air temperature probe (Remote controller) complies with the information of the manual
- The position of the DHW tank probe complies with the information of the manual
- All safety conditions have been respected

Water circuit piping and appliances

- Water connections have been carried out as per the information in the manual
- All water connections are tight
- The water line filter is installed on the HP inlet as close as possible to the HP unit and in a position that is easy to access for maintenance
- The water line filter is installed on the DHW tank Inlet/Outlet as close as possible to the HP unit and in a position that is easy to access for maintenance
- The pressure gauges with a suitable scale are installed on the Inlet and outlet of water circuit
- The flow switch is installed on the outlet of water circuit and is electrically connected
- The connection pipes are suitably supported so that these do not weigh on the appliance
- The expansion vessel and safety valve installed on the DHW circuit and suitably-sized
- The expansion vessel is installed on the water circuit and suitably-sized
- The low-loss header is installed if the water content is insufficient
- Make sure the water circuit has been washed and drained
- The air vent valves are installed at the highest points in the system
- There is no air in the system (vent if necessary)
- The shut off valves are installed on the Inlet/Outlet of system circuit and DHW circuit
- The drain valves are installed at the lowest points in the system
- The vibration damper joints are installed on the Inlet/Outlet of system circuit
- The system water content complies with the specifications in the manual
- The DHW Electric heater has been installed in DHW tank for Legionella prevention
- Suitable water flow rate for operation of the entire unit is guaranteed as specified in the manual
- All pipes are insulated with suitable vapour barrier material to prevent formation of condensation and heat loss, with control and shut-off devices protruding from the insulation

Electrical connections

- All electrical connections are tight
- Electrical connections have been carried out correctly
- Voltage is within a tolerance of 10% of the rated voltage for the HP unit
- Power supply electrical complies with the data on the rating plate and specified in the manual
- The earth wires connected securely

10. Installation check and Test operation

10.2 Test operation

Test operate the system according to the manual.

Check if the system operates normally.

- The circulating water go to the stipulated flow range
- The temperature adjustment and timer operation possible
- The system is free of abnormal noises

Final verification

DANGER

- After installation, verify there are no refrigerant gas leaks.
- In the event of gas leaks during installation, immediately ventilate the room.
- In the event of refrigerant gas leaks indoors and near a source of heat, like a cooker, poisonous gases can be emitted.

If one of the following events verifies contact the aftersales assistance service:

- Overheated or damaged power supply cable.
- Unusual noises during operating.
- Frequent activation of the protective devices.
- Unusual smells (like burning).

11. Service and Maintenance

11.1 Error code display

In the event that an error is detected, the error code will be displayed in Remote controller and PCB (Terminal) display. As for the display in Remote controller, LED (red) on ON/OFF switch will be flashed, and warning icon and 2 or 3 digits error code will be displayed on LCD screen. Error code (2digits) will be displayed on the PCB (Terminal) display.

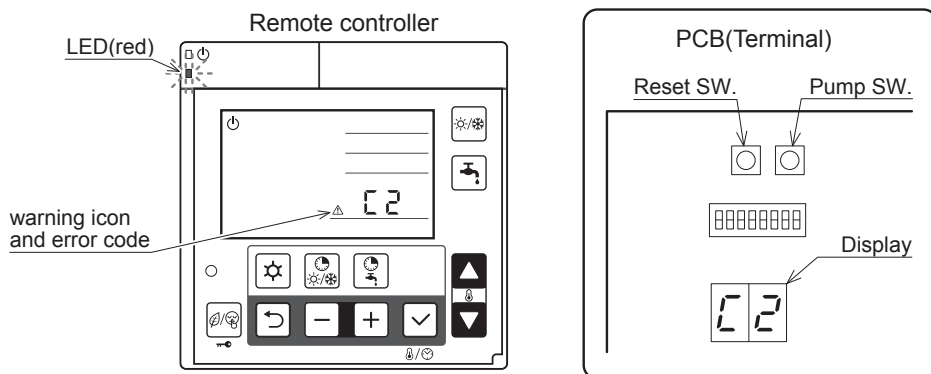

11.2 Error history display

•The previous 10 error codes can be displayed on PCB (Terminal) display.

Procedure to display on PCB(Terminal) display

- Press Pump SW and Reset SW on PCB (Terminal) at the same time for 5 seconds, error history order and error code will be displayed alternately. The first one is the latest error code.
- Press Pump SW to go up the history order and it is up to 10th error code then go back to the latest error code.
- When there is no error history, “--” will be displayed.

If no operation is carried out for 5 minutes, or the same procedure is operated to display error history, the display returns to normal display.

Deletion of the error history

- During error code displaying, press Reset SW for 10 seconds to delete the error history.

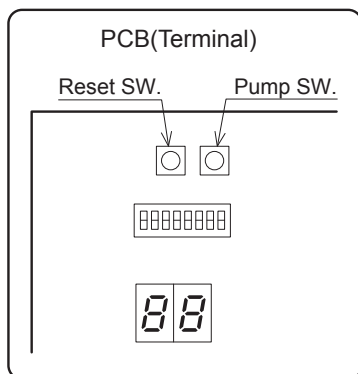

11. Service and Maintenance

11.3 Method of reset error code display

The procedure to reset the error display differs to error codes and there are 3 types to reset; Auto, Power OFF, and Manual.

See “List of Error codes” for the procedure to reset each error code.

Auto : Automatically. Once it returns to normal condition, the error will be reset.

When the unit stops, it may not possible to reset automatically. Then, it shall be reset manually.

Power OFF : Manually. If HP unit returns to normal condition, turn OFF the power supply once and turn ON again, then the error will be reset.

Manual : Manually. To reset the error, press – and + button of the Master Remote controller at the same time for 3 seconds, or press Reset SW on the PCB (Terminal).

It is possible to reset by turning OFF → ON of power supply.

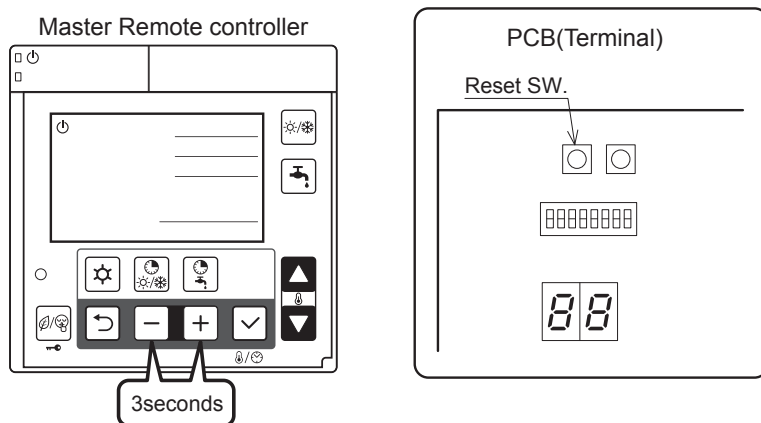

11. Service and Maintenance

11.4 List of Error codes

HP unit alarms

Error codes	Appearance, Portion, Parts seemed wrong	Method of check	Troubleshooting	Figure/ Table	Error reset	
—	—	Power supply	Check the power supply	Confirm the power supply	—	—
		PCB (Main)	Other than described above	PCB (Main) should be replaced		
A0	DC voltage error	Fan motor	Operate without lead wire for Fan motor	If the same error code appears again, PCB (Main) or Pump should be replaced If other error codes appear, Fan motor should be replaced	—	Power OFF
		Pump	Operate without lead wire for Pump	If the same error code appears again, PCB (Main) or Fan motor should be replaced If other error codes appear, Pump should be replaced	—	
		Reactor	Check the resistance by tester (0.1Ω at 20°C)	If the reactor is faulty, it should be replaced	—	
		PCB (Main)	Check the voltage of Fan motor by tester Check the voltage of Pump by tester	If the voltage is abnormal, PCB (Main) should be replaced	Fig. 1	
		Power supply	Check the power supply	Confirm the power supply	—	
A1	Discharge temperature error	Sensor, Temp. Discharge	Check the resistance by tester	If the sensor is faulty, it should be replaced	Table 2	
		Gas leakage	Check the service valve and refrigerant circuit (pipe)	Collect refrigerant once, then recharge with prescribed mass	—	
A2	Protective action against excess	Unreasonable operation under/overload	Check the place of installation (blockage of air inlet & outlet) Check the excess gas	Ensure the installation position to avoid blockage of air inlet & outlet If excess gas is observed, collect all refrigerant once, then recharge with prescribed mass	—	Manual
		Drop of power voltage	Check the power voltage (230V)	Confirm the power supply voltage (230V)		
	Current DC current detection	PCB (Main)	Operate without the junction connector of Compressor lead wire	If the same error code appears again, PCB (Main) should be replaced		
		Momentary stop of power (In case of lightning)	—	Restart operation		
A3	Abnormal current detection	PCB (Main)	—	PCB (Main) should be replaced	—	
			Compressor	Other than described above		Compressor should be replaced (*1)
A4	Protective action against excess	Unreasonable operation under/overload	Check the place of installation (blockage of air inlet & outlet) Check the excess gas	Ensure the installation position to avoid blockage of air inlet & outlet If excess gas is observed, collect all refrigerant once, then recharge with prescribed mass	—	
				Current AC current detection		Drop of power voltage
	Momentary stop of power (In case of lightning)	—	Restart operation			

(*1) WARNING : The refrigerant circuit contains flammable gas. All parts must be inspected and replaced by a licensed technician.

11. Service and Maintenance

Error codes	Appearance, Portion, Parts seemed wrong		Method of check	Troubleshooting	Figure/ Table	Error reset
A5	Abnormal revolution of Compressor	Unreasonable operation under/overload	Check the place of installation (blockage of air inlet & outlet) Check the excess gas	Ensure the installation position to avoid blockage of air inlet & outlet If excess gas is observed, collect all refrigerant once, then recharge with prescribed mass	—	Manual
		Drop of power voltage	Check the power voltage (230V)	Confirm the power supply voltage (230V)		
		Clogged the water Pump and/or water circuit	Check the Pump and water circuit	Remove the blockage, then restart operation	—	
		Drop of power voltage	Check the power voltage (230V) during operation	Confirm the power supply voltage (230V)		
		Momentary stop of power (In case of lightning)	—	Restart operation		
		Compressor or PCB (Main)	Other than described above	PCB (Main) or compressor should be replaced(*1)		
A7	Defrost temp. sensor error	Sensor, Temp. Defrost	Check the resistance by tester	If the sensor is faulty, it should be replaced	Table 3	Auto
A8	Discharge temp. sensor error	Sensor, Temp. Discharge	Check the resistance by tester (*2)	If the sensor is faulty, it should be replaced	Table 2	
C1	Upper Fan motor error (1049ZU-CH1) (1249ZU-CH)	Fan motor	Check the voltage of Fan motor by tester	If the voltage is normal, Fan motor should be replaced If the voltage is abnormal, PCB (Main) should be replaced	Fig. 1	Manual
		PCB (Main)				
C2	Outdoor temp. sensor error	Sensor, Temp. Outdoor	Check the resistance by tester	If the sensor is faulty, it should be replaced	Table 1	Auto
C3	Fan motor error (0449ZU-CH1) (0649ZU-CH) (0649ZU-CH1) (0849ZU-CH)	Fan motor	Check the voltage of Fan motor by tester	If the voltage is normal, Fan motor should be replaced If the voltage is abnormal, PCB (Main) should be replaced	Fig. 1	Manual
	Lower Fan motor error (1049ZU-CH1) (1249ZU-CH)	PCB (Main)				
C4	Rise of temperature of PCB (Main) (above 110°C)	Miss-installation	Check the place of installation (blockage of air inlet & outlet)	Ensure the installation position to avoid blockage of air inlet & outlet	—	
		Sensor, Temp. PCB (Main)	—	PCB (Main) should be replaced		
C5	PCB (Main) sensor error	Sensor, Temp. PCB (Main)	—	PCB (Main) should be replaced	—	Auto
C6	PCB (Main) error	PCB (Main)	—	PCB (Main) should be replaced	—	Power OFF

(*1) WARNING : The refrigerant circuit contains flammable gas. All parts must be inspected and replaced by a licensed technician.

(*2) In case of detecting open circuit of the discharge temperature sensor, error display appears 10 minutes after start operating.

In case of detecting short circuit of the discharge temperature sensor, error display appears immediately.

11. Service and Maintenance

Error codes	Appearance, Portion, Parts seemed wrong		Method of check	Troubleshooting	Figure/ Table	Error reset
C7	PCB (Controller) serial error	Miss wiring or rare contact [PCB (Main) - PCB (Controller) connecting cable]	Check the wiring connection and rare contact	After correcting miss wiring, restart operation	—	
		PCB (Controller)	Other than described above	PCB (Controller) should be replaced		
		PCB (Main)	Other than described above	PCB (Main) should be replaced		
		EARTH WIRE	—	Check if earth wire is properly installed		
C8	PCB (Main) error	PCB (Main)	Turn off the power supply, wait for about 3 minutes, then power up again	If the same error code appears, PCB (Main) should be replaced	—	Auto
			Check loose cable connections and contacts of reactor			
E4	Outgoing water temp. sensor error	Sensor, Temp. Outgoing water	Check the resistance by tester	If the sensor is faulty, it should be replaced	Table 4	
E5	Return water temp. sensor error	Sensor, Temp. Return water	Check the resistance by tester	If the sensor is faulty, it should be replaced	Table 4	
E6	Plate heat exchanger temp. sensor error	Sensor, Temp. Plate heat exchanger	Check the resistance by tester	If the sensor is faulty, it should be replaced	Table 3	
EL	Detection of dry-running pump	Insufficient water in the water circuit	Check the water circuit	Repair any water leakages Refill the water circuit	—	
		Air ingress inside the water circuit	Check the water circuit	Remove air from the water circuit		
		Flow sensor	—	Flow sensor should be replaced		
FU	High pressure switch is operating	Outside air recirculation	Check the place of installation (blockage of air inlet & outlet)	Make sure the position doesn't block the air inlet and outlet	—	Manual
		Clogged water circuit	Check temperature difference of Outgoing/Return water (see Monitor display function) Large difference means flow rate is too low	Remove the blockage, then restart operation		
LL	Water circuit flow rate is low	Insufficient water in the water circuit	Check the water circuit	Repair any water leakages Refill the water circuit	—	Auto
		Air ingress inside the water circuit	Check the water circuit	Remove air from the water circuit		
		Flow sensor	—	Flow sensor should be replaced		
P1	Pump error	Pump	—	Pump should be replaced	—	Manual
		PCB (Main)		PCB (Main) should be replaced		
P3	High pressure switch error	High pressure switch	Check loose cable connections and contacts	If the same error code appears, high pressure switch should be replaced (*1)	—	Power OFF

(*1) WARNING : The refrigerant circuit contains flammable gas. All parts must be inspected and replaced by a licensed technician.

11. Service and Maintenance

Error codes	Appearance, Portion, Parts seemed wrong		Method of check	Troubleshooting	Figure/ Table	Error reset
Not cool down Not warm up	4way valve		Check the resistance of 4way valve coil by tester	If 4way valve coil is blown,it should be replaced	Fig. 2	—
	Defrost heater		Check the resistance of Defrost heater by tester	If Defrost heater is blown,it should be replaced	Fig. 3	
	Short cycle (insufficient air circulation)		Check the blockage of air inlet & outlet	Ensure the installation position to avoid blockage of air inlet & outlet	—	
	Sensor,Temp. Outgoing water and Return water		Check the resistance by tester	If any of these sensors is faulty, it should be replaced	Table 4	
	Gas leakage		Check the service valve and refrigerant circuit (pipe)	After fixing the leakage point,collect the refrigerant once,then recharge with prescribed mass		
	Clogged water circuit		Check temperature difference of Outgoing/Return water (see Monitor display function) Large difference means flow rate is too low	Remove the blockage,then restart operation	—	
	Electric expansion valve		Check the resistance of Electric expansion valve coil	If Electric expansion valve coil is blown, it should be replaced		

PCB(Controller) and PCB(Terminal) alarms

Error codes	Appearance, Portion, Parts seemed wrong		Method of check	Troubleshooting	Figure/ Table	Error reset
L0	EEPROM error	PCB(Controller) and PCB(EEPROM)	—	PCB(Controller) and PCB(EEPROM) should be replaced	—	Power OFF
L1	DHW temp. sensor error	Sensor,Temp. DHW tank	Check the resistance by tester	If the sensor is faulty, it should be replaced	Table 3	Auto
L2	Outdoor temp. sensor error	Sensor,Temp.Outdoor (Additional)	Check the resistance by tester	If the sensor is faulty, it should be replaced	Table 5	
L3	Buffer temp. sensor error	Sensor,Temp. Buffer tank	Check the resistance by tester	If the sensor is faulty, it should be replaced	Table 3	
L4	Mix water temp. sensor error	Sensor,Temp. Mix water	Check the resistance by tester	If the sensor is faulty, it should be replaced	Table 3	
L5	Humidity sensor error	Sensor, Humidity	Check the resistance by tester	If the sensor is faulty, it should be replaced	Fig. 4	Manual
L6	Flow switch error	Clogged the water pump and/or water circuit	Check the pump and the water circuit	Remove any obstructions, clean the water filter, unblock the pump	—	
		Flow switch	Other than described above	Flow switch should be replaced		
L7	Mixing valve error	Clogged the water pump and/or water circuit	Check the pump and the water circuit	Remove any obstructions, clean the water filter, unblock the pump	—	
		PCB(Terminal)	Check the voltage by tester	PCB(Terminal) should be replaced	Fig. 5,6	
		Mixing valve	Other than described above	Mixing valve should be replaced	—	
L8	Room temp. (Master Remote controller) error	Sensor,Temp.Room (Master Remote controller)	—	Master Remote controller should be replaced	—	Auto

11. Service and Maintenance

Error codes	Appearance, Portion, Parts seemed wrong		Method of check	Troubleshooting	Figure/ Table	Error reset
L9	Room temp. (Slave Remote controller) error	Sensor,Temp.Room (Slave Remote controller)	—	Slave Remote controller should be replaced	—	Auto
LC	Anti Legionella Function Not completed	DHW used during Anti Legionella	Check if DHW used during Anti Legionella	Restart operation, don't use much DHW during Anti Legionella	—	Auto(*3) Manual
		Clogged the water pump and/or water circuit	Check the pump and the water circuit	Remove any obstructions, clean the water filter, unblock the pump		
		Heat source setting failure	Check parameter and heat source	After correcting parameter settings or replace heat source		
740	Master Remote controller communication error	• Incorrect Master Remote controller wiring or Dip SW setting • Loose interface connection cable or contacts	Check loose cable connections and contacts Check Dip SW setting (Back side of Remote controller)	After having corrected the wiring and Dip SW setting, restart operation	—	
		Master Remote controller	Other than described above	Master Remote controller should be replaced		
		PCB(Controller)	Other than described above	PCB(Controller) should be replaced		
750	Slave Remote controller communication error	• Incorrect Slave Remote controller wiring or Dip SW setting • Loose interface connection cable or contacts	Check loose cable connections and contacts Check Dip SW setting (Back side of Remote controller)	After having corrected the wiring and Dip SW setting, restart operation	—	Auto
		Slave Remote controller	Other than described above	Slave Remote controller should be replaced		
		PCB(Controller)	Other than described above	PCB(Controller) should be replaced		
E8	Remote controller communication error	• Incorrect Remote controller wiring • Loose interface connection cable or contacts	Check loose cable connections and contacts	After having corrected the wiring, restart operation	—	
		Master or Slave Remote controller	Other than described above	Master or Slave Remote controller should be replaced		
		PCB(Controller)	Other than described above	PCB(Controller) should be replaced		
F5	PCB (Main) Communication error	• Incorrect PCB(Main) wiring • Loose interface connection cable or contacts	Check loose cable connections and contacts	After having corrected the wiring, restart operation	—	
		PCB(Main)	Other than described above	PCB(Main) should be replaced		
		PCB(Controller)	Other than described above	PCB(Controller) should be replaced		
PCB(Terminal) can't be operated PCB(Terminal) doesn't display anything		Lead wire of PCB(Terminal)	Check lead wires are connected to the connectors properly	Connect the connectors to both PCB(Terminal) and PCB(Controller) steadily	—	—
			Ensure that there is no disconnection for the lead wires	Lead wires should be replaced		
		PCB(Terminal)	Other than described above	PCB(Terminal) should be replaced		
		PCB(Controller)	Other than described above	PCB(Controller) should be replaced		

(*3) When Anti Legionella Function has been completed, alarm display will reset automatically.

11. Service and Maintenance

11.5 Check and troubleshooting

Method of check Voltage, Resistance, Continuity

[Fig. 1] Voltage of Fan motor on the PCB (Main)

[AEYC-0449ZU-CH1, AEYC-0649ZU-CH]
 [AEYC-0649ZU-CH1, AEYC-0849ZU-CH]
 [AEYC-1049ZU-CH1, AEYC-1249ZU-CH]

[AEYC-1049ZU-CH1, AEYC-1249ZU-CH]

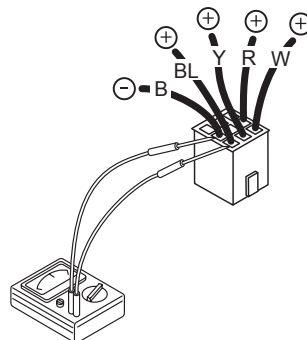
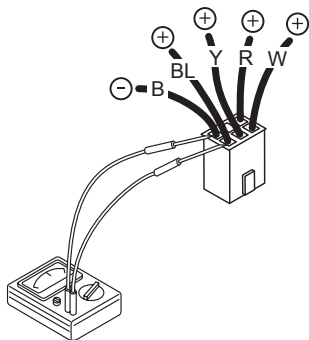

Between red ⊕ and black ⊖, approx. DC200~370V
 Between yellow ⊕ and black ⊖, approx. DC3~7V
 Between white ⊕ and black ⊖, approx. DC15V

PCB (Main) is normal

[Fig. 2] Resistance of the 4way valve coil

Take off the connector and check the resistance 4way valve coil.

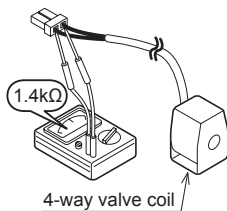

[Fig. 3] Resistance of the Defrost heater

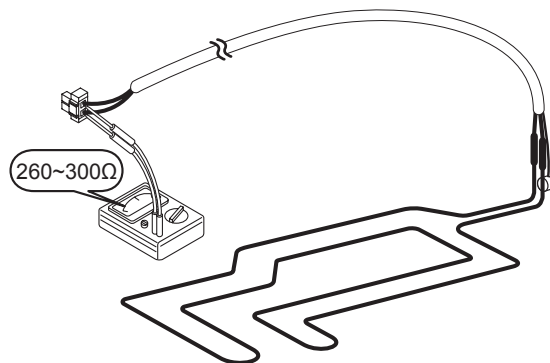

11. Service and Maintenance

[Fig. 4] Voltage of humidity sensor

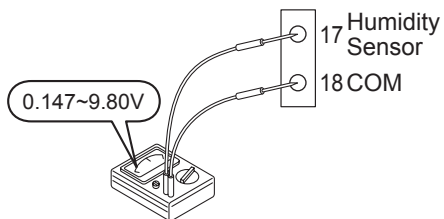

[Fig. 5] Voltage of 3way mixing valve (24VAC)

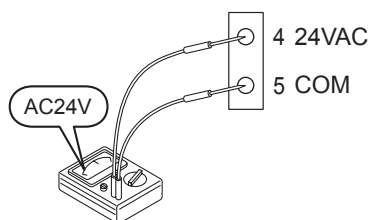

[Fig. 6] Voltage of 3way mixing valve (control)

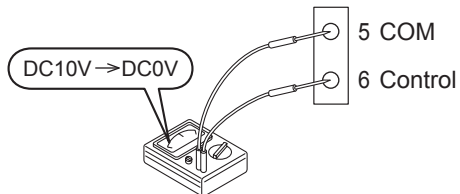

Normal operation during the Heating mode;

The voltage of 3way mixing valve decreases from 10V toward 0V in case that the mixed water temperature is higher than the water set point.

Normal operation during the Cooling mode;

The voltage of 3way mixing valve decreases from 10V toward 0V in case that the mixed water temperature is lower than the water set point.

11. Service and Maintenance

Electric character of the sensors

[Table 1] Sensor, temp. Outdoor (HP unit)

Temp.(°C)	Resistance(kΩ)
0	31
5	24
10	19
15	15
20	12
25	10
30	8.2
35	6.7
40	5.5
45	4.6
50	3.8
55	3.2

[Table 2] Sensor, temp. Discharge

Temp.(°C)	Resistance(kΩ)
10	100
20	64
35	33
40	27
50	18
80	6.4

[Table 3] Sensor, temp. Defrost/Plate heat exchanger Sensor, temp. DHW tank/Buffer tank/Mix water

Temp.(°C)	Resistance(kΩ)
0	29
5	23
10	19
15	15
20	12
25	10
30	8.3
35	6.9
40	5.7
45	4.8
50	4.1
55	3.4

[Table 4] Sensor, temp. Outgoing water/Return water

Temp.(°C)	Resistance(kΩ)
0	25
10	16
20	10
30	7.0
40	4.9
50	3.5
60	2.5

[Table 5] Sensor, temp. Outdoor (Additional)

Temp.(°C)	Resistance(kΩ)
-20	107
-15	79
-10	59
-5	44
0	34
5	26
10	20
15	16
20	13
25	10
30	8.0
35	6.5
40	5.3
45	4.3
50	3.6

11. Service and Maintenance

Wiring Diagram

AEYC-0449ZU-CH1

AEYC-0649ZU-CH

AEYC-0649ZU-CH1

AEYC-0849ZU-CH

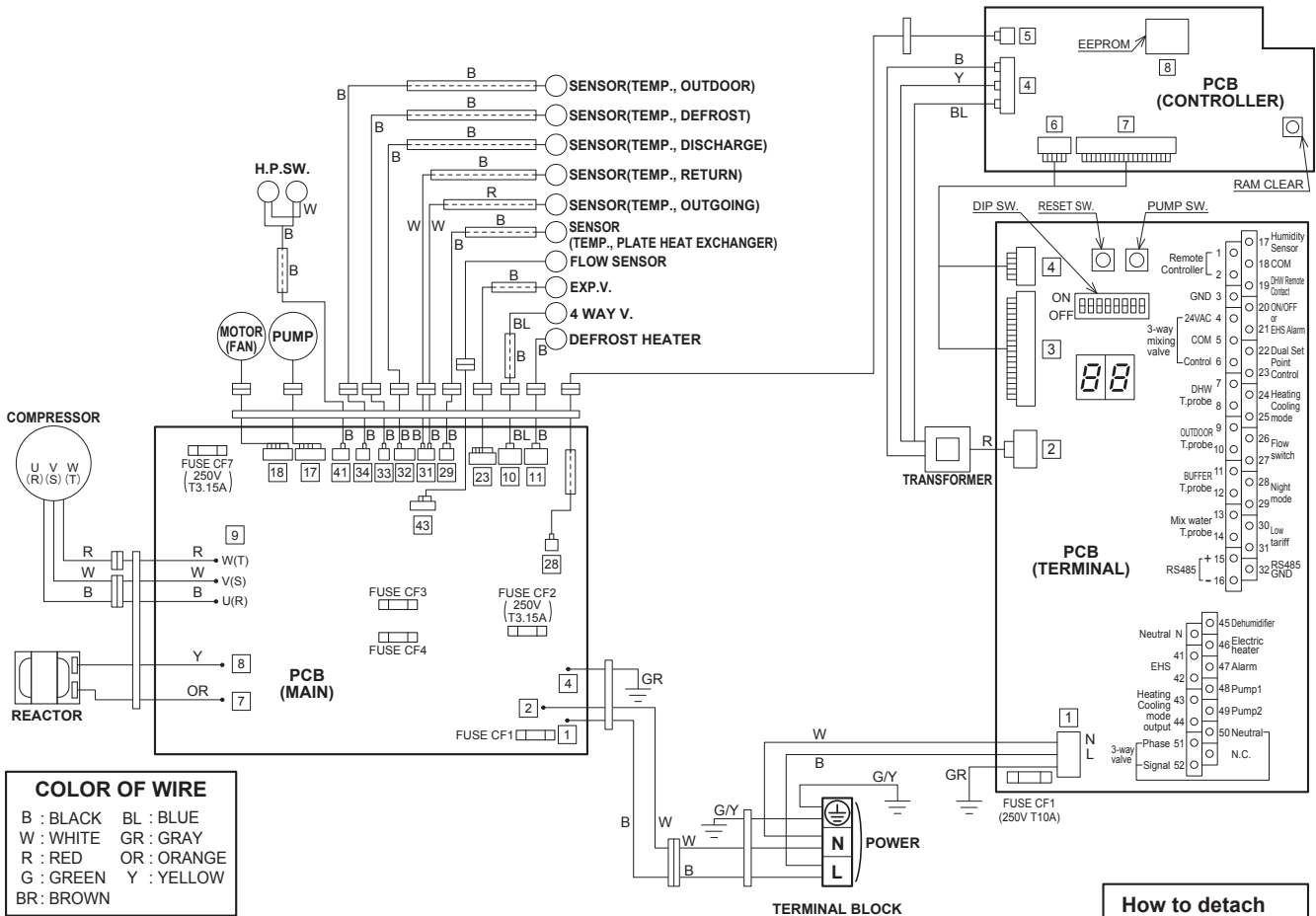

⚠ WARNING !

⚡ Electric Shock !

Warning when you fix electric components !

- Don't touch electrically charged parts, as electric shock may occur even if they are switched off.
- Be sure to wait at least 5 minutes after turning off the power.

⚠ Caution ⚡ Electric Shock High Voltage

- Do not touch any part of the electric circuit (including the wiring of thermistor and others), as it has high voltage against the ground.
- Pay attention not to damage the insulated wire when you tighten the screw, as the exposed wire may cause electric shock or malfunction.
- The circuit of a heat pump is not isolated. Do not ground a measuring instrument, as it may cause a breakdown. Also, do not touch the metal parts of a measuring instrument, as it may result in electric shock.

How to detach locking terminal

Pull off while pressing the locking lever.

Locking lever

11. Service and Maintenance

AEYC-1049ZU-CH1 AEYC-1249ZU-CH

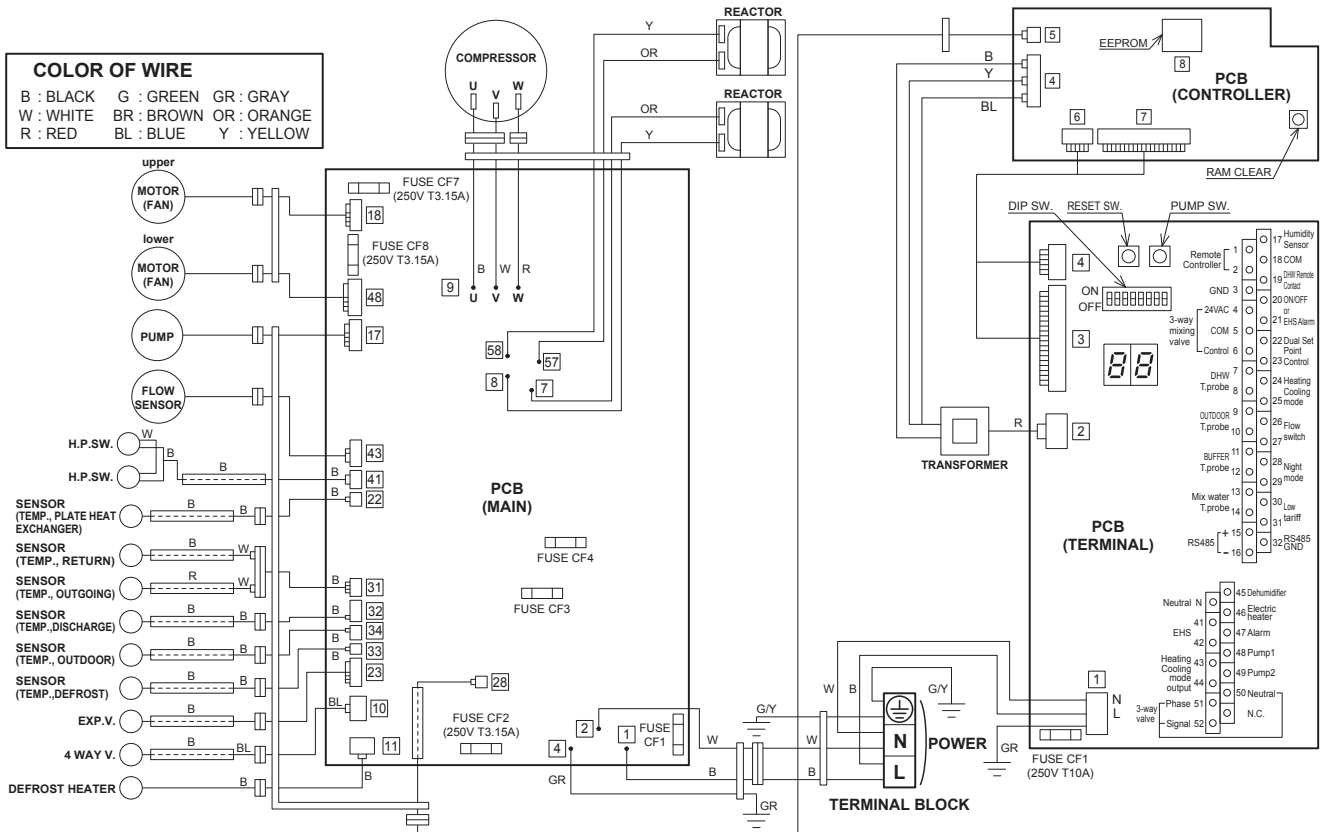

⚠ WARNING !

⚠ Electric Shock !

- Warning when you fix electric components !
- Don't touch electrically charged parts, as electric shock may occur even if they are switched off.
 - Be sure to wait at least 5 minutes after turning off the power.

⚠ Caution ⚠ Electric Shock High Voltage

- Do not touch any part of the electric circuit (including the wiring of thermistor and others), as it has high voltage against the ground.
- Pay attention not to damage the insulated wire when you tighten the screw, as the exposed wire may cause electric shock or malfunction.
- The circuit of a heat pump is not isolated. Do not ground a measuring instrument, as it may cause a breakdown. Also, do not touch the metal parts of a measuring instrument, as it may result in electric shock.

How to detach locking terminal

Pull off while pressing the locking lever.

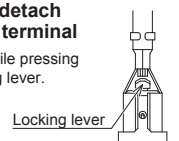

11. Service and Maintenance

11.6 Monitor display function

• The conditions and settings of HP unit can be displayed on Remote controller or PCB (Terminal) display.

Display on Remote controller

1. Press Return button for 3 seconds to enter monitor mode and display USER level value of parameter group 01. 2 digits (Code No. of parameter group 01 : default value is 00) will be displayed on the left of Remote controller screen. And its parameter value will displayed on the right of the screen (default value is ----.)
2. Push Up&Down button to change Code numbers, and push Set button to display the parameter value.
3. To return to normal display, press and hold the "Return" button for 3 seconds, or simply do nothing and leave it for about 10 minutes.

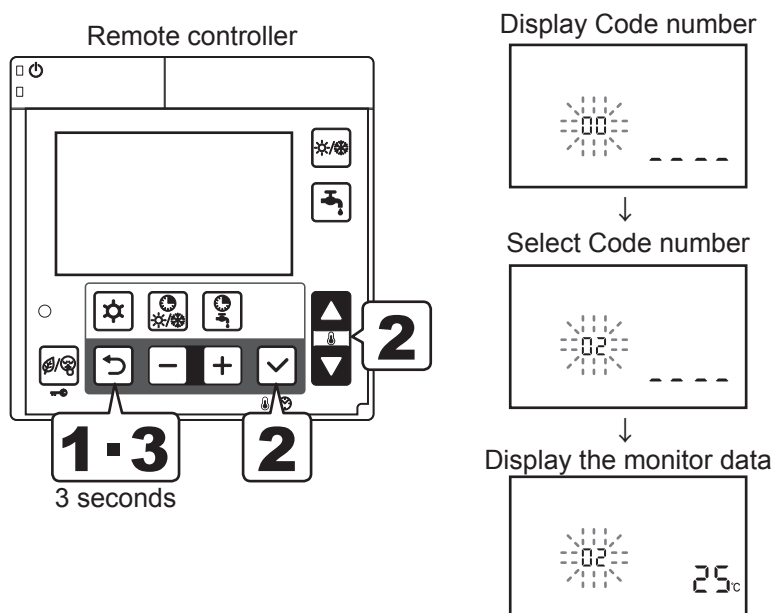

Display on PCB (Terminal) display

- Turn ON the Dip SW4 on the PCB (Terminal) to display the monitor number and monitor data alternately.
 - Push the Pump SW. of the PCB (Terminal) to switch the display number alternately.
- To return to normal display, turn OFF the Dip SW4.

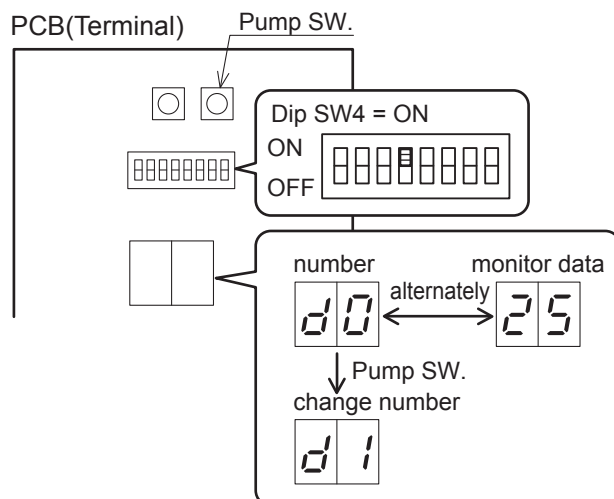

11. Service and Maintenance

Monitor display

PCB (Terminal)	Remote controller		Function description	Display & Input value				Remarks
	Number	Parameter		Default	min.	Max.	Unit	
d0	01	00	Circulating water return temperature	-	-20	100	1°C	
d1	01	01	Compressor operating frequency	-	0	200	1Hz	
d2	01	02	Discharge temperature	-	-20	150	1°C	
d3	01	03	Current consumption value	-	0	9900	100W	
—	01	04	Fan control number of rotation	-	0	1000	10rpm	
d5	01	05	Defrost temperature	-	-20	100	1°C	
d6	01	06	Outdoor air temperature	-	-20	100	1°C	
d7	01	07	Water pump control number of rotation	-	0	9900	100rpm	
d9	01	09	Circulating water outgoing temperature	-	-20	100	1°C	
—	01	10	Selected operating mode <u>0=Heating/Cooling OFF</u> 1=Heating 2=Cooling	0	0	2	-	Set by Remote controller or remote contact
	01	11	Room set temperature of Zone1(Master)	25.0	12.0	40.0	0.5°C	Set by Master Remote controller
	01	12	Room set temperature of Zone2(Slave)	25.0	12.0	40.0	0.5°C	Set by Slave Remote controller
	01	13	Selected DHW operating mode <u>0=disable</u> 1=Comfort 2=Economy 3=Force	0	1	3	-	
	01	14	Day <u>0=Monday</u> , 1=Tuesday, 2=Wednesday, 3=Thursday, 4=Friday,5=Saturday, 6=Sunday	0	0	6	-	
	01	15	Clock	12:00	0:00	23:59	1min	Set by Remote controller
	01	16	Heating/Cooling time bands setting Zone1 <u>0=disable</u> 1=active	0	0	1	-	
	01	17	Heating/Cooling time bands setting Zone2 <u>0=disable</u> 1=active	0	0	1	-	
	01	18	DHW time band setting <u>0=disable</u> 1=enable	0	0	1	-	
	01	19	Low tariff and Night mode setting <u>0=disable</u> 1=Low tariff 2=Night mode 3=Low tariff and Night mode	0	0	3	-	Set by Remote controller or remote contact
	01	20	Room relative humidity value	-	0	100	1%	
d4	01	72	Plate heat exchanger temperature	-	-20	100	1°C	

11. Service and Maintenance



11.7 Maintenance

WARNING

Before performing any maintenance make sure you have removed the power acting on the switch.

- Check that the staff wears suitable individual protection devices.
- The extraordinary maintenance operations must be performed by qualified staff.
- The Heat pump contains refrigerant that requires special disposal.
- On conclusion of its useful life, remove the air conditioner with caution.
- The HP unit must be taken to a relevant collection centre or the dealer, which will dispose of it correctly and suitably.

Do not use the followings for cleaning







 <p>Gasoline, benzine, thinner or cleanser may damage the coating of the unit.</p>	 <p>Hot water over 40°C (104°F) may be caused discoloring or deformation.</p>
--	---

Replacing the circulating water







- For the circulating water, use anti-freeze. Replace it every few years.
The replacement period depends on the type of anti-freeze. Ask at the store where you purchase your anti-freeze.
- For anti-freeze, always use our genuine anti-freeze.
Do not use anti-freeze from another company or old anti-freeze. Never mix anti-freeze.
Also, do not dilute anti-freeze.
Not only can this make normal operation impossible but it can cause reduced performance or breakdown.

Product Label







AEYC-0449ZU-CH1

AIR TO WATER HEAT PUMP	
MODEL AEYC-0449ZU-CH1	
MAX.CURRENT	12.0A
MAX.PRESSURE:DISCHARGE	35.0bar(3.5MPa)
MAX.PRESSURE:SUCTION	16.0bar(1.6MPa)
MAX.PRESSURE:HYDRAULIC CIRCUIT	3.0bar(0.3MPa)
POWER SUPPLY	1Ph~ 50Hz 230V
MOISTURE RESISTANCE	IPX4
REFRIGERANT	R290 GWP 3
FACTORY CHARGE	0.5kg
0.0015 TONS CO ₂ EQUIVALENT	
WEIGHT	66kg
SERIAL NUMBER	
MADE IN JAPAN	yr 
    	
CHOFU SEISAKUSHO CO.,LTD.	
2-1 CHOFU OHGIMACHI, SHIMONOSEKI CITY, YAMAGUCHI PREF., JAPAN	







AEYC-0649ZU-CH

AIR TO WATER HEAT PUMP	
MODEL AEYC-0649ZU-CH	
MAX.CURRENT	12.0A
MAX.PRESSURE:DISCHARGE	35.0bar(3.5MPa)
MAX.PRESSURE:SUCTION	16.0bar(1.6MPa)
MAX.PRESSURE:HYDRAULIC CIRCUIT	3.0bar(0.3MPa)
POWER SUPPLY	1Ph~ 50Hz 230V
MOISTURE RESISTANCE	IPX4
REFRIGERANT	R290 GWP 3
FACTORY CHARGE	0.5kg
0.0015 TONS CO ₂ EQUIVALENT	
WEIGHT	66kg
SERIAL NUMBER	
MADE IN JAPAN	yr 
    	
CHOFU SEISAKUSHO CO.,LTD.	
2-1 CHOFU OHGIMACHI, SHIMONOSEKI CITY, YAMAGUCHI PREF., JAPAN	

AEYC-0649ZU-CH1

AIR TO WATER HEAT PUMP	
MODEL AEYC-0649ZU-CH1	
MAX.CURRENT	16.6A
MAX.PRESSURE:DISCHARGE	35.0bar(3.5MPa)
MAX.PRESSURE:SUCTION	16.0bar(1.6MPa)
MAX.PRESSURE:HYDRAULIC CIRCUIT	3.0bar(0.3MPa)
POWER SUPPLY	1Ph~ 50Hz 230V
MOISTURE RESISTANCE	IPX4
REFRIGERANT	R290 GWP 3
FACTORY CHARGE	0.85kg
0.0026 TONS CO ₂ EQUIVALENT	
WEIGHT	82kg
SERIAL NUMBER	
MADE IN JAPAN	yr 
    	
CHOFU SEISAKUSHO CO.,LTD.	
2-1 CHOFU OHGIMACHI, SHIMONOSEKI CITY, YAMAGUCHI PREF., JAPAN	

AEYC-0849ZU-CH

AIR TO WATER HEAT PUMP	
MODEL AEYC-0849ZU-CH	
MAX.CURRENT	16.6A
MAX.PRESSURE:DISCHARGE	35.0bar(3.5MPa)
MAX.PRESSURE:SUCTION	16.0bar(1.6MPa)
MAX.PRESSURE:HYDRAULIC CIRCUIT	3.0bar(0.3MPa)
POWER SUPPLY	1Ph~ 50Hz 230V
MOISTURE RESISTANCE	IPX4
REFRIGERANT	R290 GWP 3
FACTORY CHARGE	0.85kg
0.0026 TONS CO ₂ EQUIVALENT	
WEIGHT	82kg
SERIAL NUMBER	
MADE IN JAPAN	yr 
    	
CHOFU SEISAKUSHO CO.,LTD.	
2-1 CHOFU OHGIMACHI, SHIMONOSEKI CITY, YAMAGUCHI PREF., JAPAN	

Product Label

AEYC-1049ZU-CH1

AIR TO WATER HEAT PUMP

MODEL AEYC-1049ZU-CH1

MAX.CURRENT	24.0A
MAX.PRESSURE:DISCHARGE	35.0bar(3.5MPa)
MAX.PRESSURE:SUCTION	16.0bar(1.6MPa)
MAX.PRESSURE:HYDRAULIC CIRCUIT	3.0bar(0.3MPa)
POWER SUPPLY	1Ph~ 50Hz 230V
MOISTURE RESISTANCE	IPX4
REFRIGERANT	R290 GWP 3
FACTORY CHARGE	1.15kg
	0.0035 TONS CO ₂ EQUIVALENT
WEIGHT	117kg

SERIAL NUMBER

MADE IN
JAPAN

yr



R290
Refrigerant



**CHOFU SEISAKUSHO
CO.,LTD.**

2-1 CHOFU OHGIMACHI,
SHIMONOSEKI CITY,
YAMAGUCHI PREF.,
JAPAN

CE
0035

AEYC-1249ZU-CH

AIR TO WATER HEAT PUMP

MODEL AEYC-1249ZU-CH

MAX.CURRENT	24.0A
MAX.PRESSURE:DISCHARGE	35.0bar(3.5MPa)
MAX.PRESSURE:SUCTION	16.0bar(1.6MPa)
MAX.PRESSURE:HYDRAULIC CIRCUIT	3.0bar(0.3MPa)
POWER SUPPLY	1Ph~ 50Hz 230V
MOISTURE RESISTANCE	IPX4
REFRIGERANT	R290 GWP 3
FACTORY CHARGE	1.15kg
	0.0035 TONS CO ₂ EQUIVALENT
WEIGHT	117kg

SERIAL NUMBER

MADE IN
JAPAN

yr



R290
Refrigerant



**CHOFU SEISAKUSHO
CO.,LTD.**

2-1 CHOFU OHGIMACHI,
SHIMONOSEKI CITY,
YAMAGUCHI PREF.,
JAPAN

CE
0035

